

**Gaber®**

**AREA|PROGETTI**

**Price List 2022**

**Gaber®**

GABER® Indoor & Outdoor Quality Design, Made in Italy

Acoustic • Outdoor • Office • Hospitality

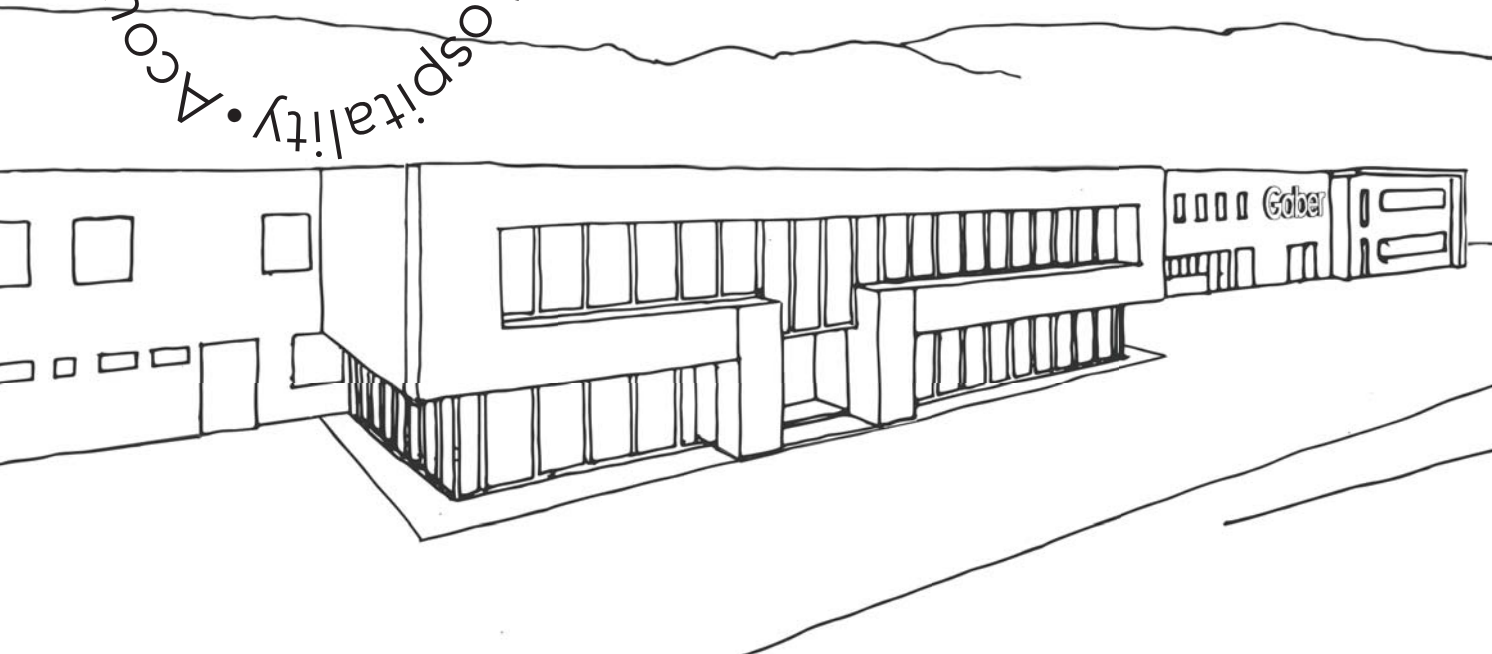

# Made in Italy

## Contract Furniture

---

Gaber designs, develops and produces furniture for the contract world, responding to the needs of design, flexibility and quality thanks to the high level of expertise achieved in the molding of plastics and metal processing. Production efficiency, continuous research and great attention to details make it possible to create practical, versatile and long-lasting furnishing solutions.

The total customization at the service of the world of architecture and design make us the ideal partner to style and furnish different environments, all dedicated to hospitality and therefore to the well-being of people sharing moments of work, meeting and relaxation. Projects in which each product has its strong, distinctive features and is part of a furnishing system designed to interpret evolving needs, new times and new meeting places.

Gaber progetta, sviluppa e produce arredi per il mondo contract rispondendo a esigenze di design, flessibilità e qualità grazie all'altissima expertise raggiunta nello stampaggio di materie plastiche e nella lavorazione del metallo. Efficienza produttiva, ricerca continua e grande attenzione ai dettagli permettono di realizzare soluzioni di arredo pratiche, versatili e durature.

La totale customizzazione al servizio del mondo dell'architettura e del design ci rendono il partner ideale per arredare diversi ambienti, tutti orientati all'hospitality e quindi al benessere di persone che condividono momenti di lavoro, di incontro e di relax. Progetti in cui ogni prodotto ha un forte carattere distintivo e si inserisce in un sistema di arredo studiato per interpretare esigenze in divenire, nuovi tempi e nuovi luoghi di incontro.

As pure expression of Made in Italy, Gabe interprets that balance between craftsmanship and industry by creating furnishings able of satisfying the tastes and needs of its international audience, with a high level of customization and a wide range of finishes.

Pura espressione del Made in Italy, Gabe interpreta quell'equilibrio tra artigianato e industria che si realizza in arredi capaci di soddisfare gusti ed esigenze di un pubblico internazionale, con un alto livello di personalizzazione e ampia gamma di finiture.



# IN THE NATURAL AND ETHICAL RESPECT

## SUSTAINABLE PRODUCTS

Gaber designs, develops and produces furniture for the world of contract, responding to the needs of design, flexibility and quality thanks to the high level of expertise achieved in the molding of plastics and processing metal. Gaber both designs and produces, enabling the realization of innovative products that take into account both human and environmental safety. Since 2000, Gaber has avoided the use of pollutants and has instead encouraged the use of the most valued recycled materials. Gaber carefully launches products complying with the environmental laws in complete respect of the rules, thereby promoting the prevention of environmental pollution.

Safeguarding the environment and a continual search for eco-friendly solutions play an important role within our company where, in recent years, all new launches have been designed and manufactured with respect for our natural environment. This begins with the separate disposal of waste in both offices and on the factory floor: paper, cardboard, plastics, packaging, metal and glass are all separated out and recycled in other internal or external industrial processes, right up to self-sufficient energy production, thanks to the latest generation of photovoltaic (PV) solar panel systems.

## PRODOTTI SOSTENIBILI

Gaber progetta, sviluppa e produce arredi per il mondo del contract, rispondendo alle esigenze di design, flessibilità e qualità grazie all'alto livello di competenza raggiunto nello stampaggio delle materie plastiche e nella lavorazione del metallo. Gaber progetta e produce complementi d'arredo di design, permettendo la realizzazione di prodotti innovativi che tengano sempre conto della sicurezza umana e ambientale. Dal 2000 Gaber ha evitato l'uso di sostanze inquinanti, incoraggiando invece, l'uso dei materiali riciclati. Gaber, sempre attenta al lancio sul mercato di prodotti conformi alle più severe leggi di salvaguardia dell'ambiente, promuovendo così la prevenzione dell'inquinamento ambientale.

La salvaguardia dell'ambiente e la continua ricerca di soluzioni eco-compatibili giocano un ruolo importante all'interno dell'azienda dove tutti i nuovi prodotti sono progettati e realizzati nel rispetto dell'ambiente naturale. Iniziando con lo smaltimento separato dei rifiuti negli uffici e nelle aree produttive: carta, cartone, plastica, imballaggi, metallo e vetro sono accuratamente separati e riciclati grazie a processi industriali sia interni che esterni e continua sino alla produzione autonoma di energia grazie ad impianti fotovoltaici di ultima generazione.

# MATERIALS / MATERIALI



## TECHNOPOLYMER / TECNOPOLIMERO

Gaber production employs exclusively high-tech thermoplastic materials, which are 100% recyclable. Each techno-polymer item is marked with a specific symbol, which shows the kind of polymer for a quick identification and a consequent recycling. Gaber produces plastic injected materials without added chemicals. These materials are purchased within the European Union, so Gaber is exempted from registration with ECHA agency (European Agency for Chemicals Substances), in the complete respect of "Reach Regulation". As far as possible, recycled plastics are sourced as a base raw material, recovered post-consumption.

La produzione Gaber impiega esclusivamente materiali termoplastici altamente innovativi, riciclabili al 100%. Ogni articolo in tecnopolimero è contrassegnato da un simbolo specifico, che identifica il tipo di polimero per una rapida identificazione ed un conseguente corretto riciclaggio. Gaber produce materiali in tecnopolimero iniettato senza aggiunta di sostanze chimiche. Questi materiali sono acquistati all'interno dell'Unione Europea, pertanto Gaber è esente dalla registrazione presso l'agenzia ECHA (Agenzia europea per sostanze chimiche), nel pieno rispetto del "Reach Regulation". Per quanto possibile, i materiali plastici riciclati vengono acquistati come materia prima di base, recuperati da post-consumo.



## METAL / METALLO

Gaber metal structures, in the full respect of our natural environment, are available with "trivalent" chroming and painted finishes. Prime-quality special epoxy powder coating used on Gaber frames enhance color stability from batch to batch and over time, increasing its corrosion resistance and achieving excellent resistance to atmospheric agents.

Le strutture metalliche Gaber, nel pieno rispetto del nostro ambiente naturale, sono disponibili con cromature "trivalenti" e finiture verniciate. La speciale verniciatura a polvere epossidica di prima qualità utilizzata sui telai Gaber migliora la stabilità del colore da lotto a lotto e nel tempo, aumentandone la resistenza alla corrosione e ottenendo un'ottima resistenza agli agenti atmosferici.



## WOOD / LEGNO

Wooden products are manufactured in accordance with the European Regulations in force regarding formaldehyde emissions from wood-based products (E1 according EN717-EN120). Gaber uses wooden raw materials coming from PEFC chain of custody certified materials.

I prodotti in legno sono realizzati in conformità alle Normative Europee vigenti in materia di emissioni di formaldeide da prodotti a base di legno (E1 secondo EN717-EN120). Gaber utilizza materie prime in legno provenienti da materiali certificati catena di custodia PEFC.

## PACKAGING / PACKAGING



Corrugated paperboard carton boxes, printed with environmentally friendly inks, are made of at least 80% recycled and recyclable materials, coming from the chain custody FSC Recycled. Packaging is sized in order to optimize storage and transport requirements, both helping the environment and saving on transport costs.

Le scatole di cartone ondulato, stampate con inchiostri ecologici, sono realizzate di almeno l'80% con materiali riciclati e riciclabili provenienti dalla catena di custodia FSC Recycled. Gli imballi sono dimensionati in modo da ottimizzare le esigenze di stoccaggio e trasporto, sia a favore dell'ambiente che di risparmio sui costi di trasporto.





## FUNCTION DESIGN AND SUSTAINABILITY / FUNZIONE DESIGN E SOSTENIBILITÀ

Compound Wood by Gaber is an advanced bio-composite where natural wood fibres are incorporated into a polyolefin matrix in order to produce a "Triple-way Ecological" material. This Triple Ecology is achieved by using wood shavings, in their turn completely recyclable, and without the need for any protective polluting treatments.

Compound Wood di Gaber è un Bio-Composito avanzato dove le fibre di legno naturali sono incorporate in una matrice poliolefinica per produrre un materiale "3 volte Ecologico". Ecologico 3 volte perché: utilizza derivati dalla lavorazione del legno, a loro volta completamente riciclabili e non necessita di trattamenti inquinanti protettivi del legno.



Gaber has received several awards for its sustainable Collections, including "Buygreen" award, a testament to Gaber's ongoing commitment to the innovation of its products and materials utilized.

Gaber ha ottenuto diversi riconoscimenti per le sue collezioni sostenibili, tra cui il premio "Buygreen", una testimonianza del continuo impegno di Gaber nell'innovazione dei suoi prodotti e dei materiali utilizzati.



Contract and sustainable furniture







**Gaber technopolymer products are made with high quality raw materials: 100% recyclable and eco-friendly.**

In the **"ZERO WASTE"** collection, Gaber products are made of completely recycled plastic material: 50% from post-consumer certified plastic waste (PCR) and 50% from industrial plastic waste (PIR).

PCR is an abbreviation for "Post Consumer Recycled" and is the raw material made from waste from the consumer/end user. PIR is an abbreviation for "Post Industrial Recycled" and is the raw material made from waste generated within the industry.

Our know-how, the use of energy generated from renewable sources, combined with the most modern technologies utilized by Gaber for the reduction and recycling of waste, creates long-lasting and functional products, which help to reduce the environmental impact of our work.

However, sustainability does not stop at the sole use of **"ZERO WASTE"** material: this material, in fact, at the end of the product's life cycle, remains totally recyclable and therefore usable to create new products, consequently eliminating material waste. Gaber is therefore at the centre of a circular economic model aimed at increasingly sustainable development, providing services that can improve people's lives and the environment, with a vision of the future aimed at promoting responsible behaviour.

**I prodotti Gaber in tecnopolimero sono realizzati con materie prime di alta qualità: riciclabili al 100% ed eco-compatibili.**

Nella collezione **"ZERO WASTE"** il prodotto Gaber è realizzato in materiale plastico completamente riciclato: 50% da scarto di materiale plastico certificato post consumo (PCR) e 50% da scarto di materiale plastico industriale (PIR).

PCR è l'abbreviazione di "Post Consumer Recycled" ed è un materiale che deriva da prodotti precedentemente utilizzati dai consumatori. PIR è invece l'abbreviazione di "Post Industrial Recycled" ed è un materiale totalmente riciclato dagli scarti creati dal produttore in fabbrica, recuperato prima di essere utilizzato dal consumatore.

Il nostro know-how, l'utilizzo di energia generata da fonti rinnovabili, unito alle più moderne tecnologie utilizzate da Gaber per la riduzione e il riciclaggio degli scarti, crea prodotti longevi e funzionali, che aiutano a diminuire a priori l'impatto ambientale del nostro lavoro. La sostenibilità non si ferma però al solo utilizzo di materiale **"ZERO WASTE"**: tale materiale, infatti, alla fine del ciclo di vita del prodotto rimane totalmente riciclabile e quindi utilizzabile per creare nuovi prodotti, eliminando di conseguenza gli sprechi di materiale.

Gaber si pone quindi al centro di un modello economico circolare volto ad uno sviluppo sempre più sostenibile, fornendo servizi in grado di migliorare la vita delle persone e dell'ambiente, con una visione del futuro volta a promuovere comportamenti virtuosi.



## SAFE PRODUCTS / PRODOTTI SICURI

In all components, parts or materials used by Gaber to make its own products, be they plastic or metal, there are no dangerous substances within the certified limits of the following test methods reports:

In tutti i componenti, parti o materiali utilizzati da Gaber per realizzare i propri prodotti, siano essi plastici o metallici, non sono presenti sostanze pericolose nei limiti certificati dei seguenti metodi e rapporti di prova:

Cadmium/Cadmio UNI EN 13656:2004 + UNI EN 13657:2004 + UNI EN ISO 11885:2009  
Lead/Piombo UNI EN 13656:2004 + UNI EN 13657:2004 + UNI EN ISO 11885:2009  
Mercury/Mercurio UNI EN 13656:2004 + UNI EN 13657:2004 + UNI EN ISO 11885:2009  
Arsenic/Arsenico UNI EN 13656:2004 + UNI EN 13657:2004 + UNI EN ISO 11885:2009  
Selenium/Selenio UNI EN 13656:2004 + UNI EN 13657:2004 + UNI EN ISO 11885:2009  
Chrome/Cromo VI CEI EN 62321:2009 Annex C  
Diisobutil ftalato (DIBP) CPSC-CH-C1001-09.3:2010  
Dibutil ftalato (DBP) CPSC-CH-C1001-09.3:2010  
Benzilbutil ftalato (BBP) CPSC-CH-C1001-09.3:2010  
Di-(2-etilesil) ftalato (DEHP) CPSC-CH-C1001-09.3:2010  
Di-n-ottil ftalato (DNOP) CPSC-CH-C1001-09.3:2010  
Diisononil ftalato (DINP) CPSC-CH-C1001-09.3:2010  
Diisodecil ftalato (DIDP) CPSC-CH-C1001-09.3:2010  
Dipentil ftalato (DPP) CPSC-CH-C1001-09.3:2010  
Dimetossietil ftalato (DMEP) CPSC-CH-C1001-09.3:2010



Gaber Material "Plastomero/Elastomero" Report n. |Rapporto di prova n. 20205954-002  
Gaber Material "Polipropilene" Report n. |Rapporto di prova n. 20205139-002  
Gaber Material "Polipropilene R" Report n. |Rapporto di prova n. 20205139-004  
Gaber Material "Polipropilene FVR" Report n. |Rapporto di prova n. 20205954-003  
Gaber Material "Poliammide" Report n. |Rapporto di prova n. 20205139-003  
Gaber Material "PC ABS" Report n. |Rapporto di prova n. 20205139-005  
Gaber Material "POM" Report n. |Rapporto di prova n. 20205139-006  
Gaber Material "Metal tube/Tubo Metallico" Report n. |Rapporto di prova n. 20205954-001  
Gaber Material "Metal Screws-Inserts/Ferramenta Metallica" Report n. |Rapporto di prova n. 20205139-001  
Gaber Composite Material "Castors/Ruote" Report n. |Rapporto di prova n. 20205139-007  
Gaber Composite Material "Swivel columns/Colonne Girevoli" Report n. |Rapporto di prova n. 20205138-002



## RESEARCH AND DEVELOPMENT / RICERCA & SVILUPPO

Gaber, aware of the need to implement courageous initiatives that respond to the ambitious sustainability programme, follows new innovation targets: the new headquarters, with fully centralized integrated automation, allows remote management to minimize any waste of energy and materials.

Particular attention has been paid to bringing back the green that characterizes our landscape: more than 6'000m<sup>2</sup> have been regenerated, transforming concrete squares and asphalt into parkland, with more than 650 new plants introduced in order to balance production needs with the surrounding environment.



Gaber, consapevole della necessità di implementare iniziative coraggiose che rispondano all'ambizioso programma di sostenibilità, ricorre a nuove dimensioni dell'innovazione: la nuova sede, integralmente controllata da domotica, permette anche la gestione da remoto per minimizzare lo spreco, di energia e di materia.

Particolare attenzione è stata dedicata al riportare il verde che caratterizza il nostro paesaggio: più di 6'000m<sup>2</sup> sono stati rigenerati, trasformando piazzali in cemento e asfalto in prati, integrando con più di 650 nuove piante l'area, al fine di equilibrare le necessità produttive con l'ambiente circostante.

## RECYCLING UNIT

When a production chain works at its best, it also prevents the creation of waste, saves resources and reduces any impact on the environment. To ensure the sustainability of its activities, Gaber invests in latest generation technologies, thanks to which energy consumption is reduced and waste materials reused.

*Gaber Recycling Unit* is a division of Gaber that allows the recycling of plastic and metal materials from post-industrial consumption, automatically optimizing the separation of different raw materials, which are thus reused in subsequent production runs.

Quando una catena produttiva funziona al meglio, previene anche la creazione di rifiuti, risparmia risorse e riduce l'impatto nei confronti dell'ambiente. Per garantire la sostenibilità delle proprie attività, Gaber investe in tecnologie di ultima generazione, grazie alle quali viene ridotto il consumo di energia e vengono ri-utilizzate le materie di scarto.

*Gaber Recycling Unit* è una divisione di Gaber che permette il riciclo delle materie plastiche e metalliche da post consumo industriale, differenziando al meglio ed in modo automatico i diversi materiali componenti dei prodotti, che vengono così riutilizzati per una nuova produzione.



## SALES CONDITIONS

- All prices are expressed in Euro (VAT excluded)
- All mentioned prices are on EX-works basis.
- Goods travel at customer's own risk.
- Minimum order quantity follows the packaging or multiply, unless otherwise specified. The first box per model must be complete; subsequent incomplete boxes incur a € 6,00 net surcharge.
- Minimum order amount: € 500,00 net. For smaller orders exceptionally accepted, anyway not lower than € 200,00, upcharge of € 25,00 net.
- Delivery time is approximate, unless differently agreed. Possible delays cannot justify any order cancellation or claim for damages.
- The goods sold through an extended payment are released under the conditions with property reserve until full settlement.
- For any dispute the place of jurisdiction will be the Court of Treviso, Italy.
- Possible complaints must be notified not later than 8 days from receipt of the goods.
- Gaber reserves the right to modify or upgrade the product without prior notice.



## GABER® LITERATURE

All Gaber® literature contains technical information and use-suggestions for those who intend to purchase or already have bought items from the Gaber® range. For Customers' interest, the Company may modify its products without any prior notice. Drawings, quoted materials and catalogue colors and price-lists are shown as a guide only and subject to tolerances. Dimensions are provided also in inches (") as a guide only. The colors displayed in Gaber® literature, related to technopolymer finishing and coverings, fabrics, leather, lacquered or painted materials, wooden items, may change from time to time. Gaber® reserves the right to suspend the production of any of its products without any notice or reason. All rights of reproduction in whole or in part of Gaber® literature, related to text, images or illustration, or transmitted by any means, electronic or mechanical, including photocopying, recording or any information storage without written permission from Gaber®, are reserved worldwide.

## MATERIALS, USE AND MAINTENANCE

### Plastic Materials

The Techno Polymer Compounds Gaber® uses on its products are characterized by high structural resistance, heat and abrasion resistance. Gaber® technopolymers are non-toxic, stain resistant, antistatic and UV-resistant: thanks to all these features these materials have excellent resistance to atmospheric agents. All these materials are recyclable in the full respect of our Natural Environment. Gaber produces plastic injected materials without added chemicals and, as far as possible, recycled technopolymers are sourced as a base raw material, recovered post-consumption.

Guidelines for correct usage: To maintain the Gaber's techno-polymer products in perfect conditions through time and guarantee a long lasting quality of the raw materials we hereby recommend very basic care instructions to be followed. Cleaning advices: Techno-polymer surfaces usually need to be cleaned with a normal cloth and warm water; for the most persistent stains a small amount of liquid soap diluted in water may be used. We recommend strictly avoid all types of abrasive substances, like for example powdered cleaning products, creams, score pads and rough sponges. Gaber's techno-polymer products can be sanitized using different substances, for more information check on the web "polypropylene chemicals resistance compatibility"; the use of these substances also depends on the temperature, pressure and concentration. It is always a good practice, after sanitizing the techno-polymer products with these substances, rinse immediately the products with water. Any liquid spilt on the product must be wiped up immediately. Even products made especially for outdoor purposes could be affected by atmospheric agents. Products may undergo exterior changes due to particular exposure to heat, humidity and salinity. Products may change color and shade if exposed to direct sunlight. An appropriate and frequent maintenance and cleaning of the products enhances its durability. Maintenance has to be carried out by experienced staff.

Gaber® glides and floorpads are made of blended rubber for heavy-duty use and are designed to minimize noise. Certain Gaber® items come ready-fitted with felt floorpads, specifically for hard or especially delicate floors.

Gaber® manufactures some bespoke products of its collection with fire retardant techno polymer: the additives that make the fireproof plastic can substantially change the aesthetics and durability of the product.

### Steel

High-resistance steel is used to produce frames for chairs, stools and tables by using square or round tubes as well as solid rod. Products are available in chrome or painted finishes. Special epoxy powder coating used on many Gaber® structures achieves excellent resistance to atmospheric agents.

### Aluminum

Gaber® use aluminum to produce frames for chairs, stools and tables. Aluminum surfaces can be anodized, and Gaber® use this special treatment in order to increase resistance to corrosion.

Guidelines for correct usage: both steel and aluminum surfaces usually need to be cleaned with a normal cloth and warm water. For the most persistent stains, a small amount of mild liquid soap diluted in water may be used. Any liquid spilt on the product must be wiped up immediately. We recommend avoiding all types of abrasive creams or pastes, abrasive sponges, chlorine, bleach or strong detergents.

### Wood

Our wooden products are produced in accordance with the European Regulations in force regarding formaldehyde emissions from wood-based products.

Guidelines for correct usage: Wooden products, being natural materials, can be damaged easily. Small impurities or imperfections are within quality standard range. Plywood surfaces need to be cleaned with a cloth and water. We recommend drying immediately after the cleaning process.

### Flexible polyurethane padding

The flexible polyurethane cold-pressed paddings Gaber® uses on some of its upholstered products do not contain CFC/HCFC (ODP=0: do not contribute to the reduction of the atmospheric ozone layer), they are fire-retardant class 1-IM UNI 9175 / CMHR following European Standards.

### Coverings: Fabrics and Leathers

Gaber® uses fabrics and leathers that belong to a wide range of colors and patterns, which are all tested in order to achieve the best performance, among which resistance to abrasion and artificial light. Fire-retardant fabrics and eco-leather upholstery are also available.

Guidelines for correct usage: Clean leathers with a soft cloth with water. Refer to technical specifications for fabric cleaning.

## PACKAGING AND RECYCLING

Our packages are designed to optimize storage and transport requirements, they are made of 90% recycled raw material and are completely recyclable in themselves. The optimization of packaging in terms of volume and weight delivers a lower consumption of energy in many forms, helping the environment and a consequent saving on transport costs. In order to avoid the loss of components, packaging must be disposed only after completing the assembly of the products. Once the product has been dismantled, the product itself or its components must be given to public garbage system, according to local rules.

## INNAPROPRIATE USES OF THE PRODUCT

Avoid any improper use of the product; do not step on the product, do not stand on footrest or on armrests, do not seat on the back or on armrest, do not use the chair as a ladder. The product should not be subjected to swinging back and forwards that may damage the furniture or result in injury to the user. When lifting or moving the product, hold it by the main structure and not just under the seat. Gaber® will accept no liability for any damages caused to property or persons subsequent to incorrect or improper handling of the product. Gaber® also declines any responsibility in cases of damage caused to fragile floors.



## CONDIZIONI GENERALI DI VENDITA

- I prezzi sono espressi in Euro (IVA esclusa)
- Resa della merce: franco fabbrica.
- La merce viaggia a rischio e pericolo del committente
- Ordine Minimo: pari all'imballo o multipli dello stesso, salvo diversamente specificato. Il primo imballo per ogni modello deve essere completo, ulteriori imballi incompleti subiranno un sovrapprezzo di € 6,00 netti.
- Importo minimo ordine: € 500,00 netti. Per ordini inferiori accettati eccezionalmente, comunque non inferiori a € 200,00, addebito di spese fisse per € 25,00 netti.
- I tempi di consegna sono indicativi salvo nostra conferma esplicita. Eventuali ritardi non possono dar luogo a pretese di danni o annullamenti dell'ordine.
- La merce venduta con pagamento dilazionato è rilasciata con condizioni di riserva di proprietà fino a completo pagamento.
- Per ogni controversia è competente il foro di Treviso, Italia.
- Eventuali reclami devono essere comunicati entro 8 giorni dal ricevimento della merce.
- Gaber si riserva la facoltà di apportare modifiche o migliorie senza alcun preavviso.

## DOCUMENTAZIONE GABER®

La documentazione Gaber® contiene informazioni tecniche e consigli d'uso per chi vuole acquistare o possiede articoli facenti parte della gamma prodotti Gaber®. Nell'interesse della clientela, Gaber® si riserva il diritto di modificare i propri modelli in ogni momento, senza obbligo di preavviso. I disegni, le quote, i materiali ed i colori dei cataloghi e del listino Gaber® si intendono a titolo puramente indicativo, e soggetti a tolleranze. Le dimensioni in pollici (") sono da considerarsi indicative. I toni di colore rappresentati o presenti nelle palette colori e rivestimenti, relativi ai tessuti, alla pelle, alle laccature, ai vetri, e alle essenze legno, sono indicativi, in quanto passibili di variazioni da partita a partita. Gaber® declina ogni responsabilità in relazione a leggere differenze di tonalità. Gaber® si riserva inoltre il diritto di ritirare, sospendere o cessare la produzione di ogni singolo suo prodotto in qualsiasi momento e a sua discrezione senza darne preventivo avviso. Tutti i diritti di riproduzione, anche parziale, di cataloghi e listini Gaber® relativi a testi, immagini, illustrazioni, disegni, sia con mezzi meccanici che elettronici, incluso fotocopie o la formazione di sorgenti di informazione, senza il preventivo permesso scritto di Gaber®, sono globalmente riservati.

## MATERIALI UTILIZZATI E MANUTENZIONE

### Le Materie Plastiche

I compound di tecnopolimeri utilizzati da Gaber® nella realizzazione dei propri prodotti sono caratterizzati da un'elevata resistenza strutturale, termica e all'abrasione. Il tecnopolimero componente dei prodotti Gaber® è atossico, antimacchia, antistatico e anti-uv: qualità che lo rendono ottimamente resistente agli agenti atmosferici. I tecnopolimeri utilizzati da Gaber® sono integralmente riciclabili, nel pieno rispetto del nostro Ambiente Naturale. Gaber produce articoli termoplastici senza additivi chimici e, ove possibile, vengono utilizzati tecnopolimeri riciclati derivanti da post-consumo.

**Piccole Accortezze:** Per mantenere i prodotti Gaber in tecnopolimero in perfette condizioni nel tempo e garantire una qualità duratura delle materie prime, raccomandiamo di seguire le seguenti semplici istruzioni di utilizzo e manutenzione. Consigli per la pulizia: normalmente le superfici in tecnopolimero devono essere pulite con un normale panno e acqua calda; per le macchie più persistenti si può utilizzare una piccola quantità di sapone liquido diluito in acqua. Si consiglia di evitare rigorosamente tutti i tipi di sostanze abrasive, come ad esempio prodotti per la pulizia in polvere, creme, tamponi e spugne ruvide. I prodotti in tecnopolimero Gaber possono essere sanificati utilizzando diverse sostanze, per maggiori informazioni verificare sul web "compatibilità resistenza chimica polipropilene"; l'uso di queste sostanze dipende anche dalla temperatura, pressione e concentrazione. È sempre buona norma, dopo aver igienizzato i prodotti in tecnopolimero con queste sostanze, sciacquare immediatamente i prodotti con acqua. I liquidi versati sul prodotto devono essere asciugati subito. I prodotti destinati all'uso esterno subiscono comunque nel tempo l'azione degli agenti atmosferici. Eventuali alterazioni superficiali possono verificarsi a specifiche condizioni di temperatura, umidità e salinità. Il prodotto se esposto alla luce diretta del sole può essere soggetto a variazioni di colore. Una corretta e frequente manutenzione e pulizia aumentano la durabilità del prodotto. Interventi di manutenzione devono essere eseguiti da personale esperto.

I tappi e le protezioni dei prodotti Gaber® sono realizzati in una miscela di gomma ad alta resistenza all'usura, atta a diminuire il rumore da trascinamento. Alcuni prodotti Gaber® sono dotati di tappi con feltri, adatti a pavimenti rigidi e più delicati.

Gaber® realizza su commessa alcuni prodotti della propria collezione con tecnopolimeri ignifughi: gli additivi che rendono il manufatto plastico ignifugo possono variare sostanzialmente l'estetica e la resistenza del prodotto.

### L' Acciaio

L'acciaio ad alta resistenza è utilizzato nelle strutture di tavoli, sedie e sgabelli, realizzati da Gaber® per mezzo di tubolari a sezione quadrata e rotonda, o con tondino. I prodotti sono disponibili con finitura cromata o verniciata. La speciale verniciatura a polveri epossidiche utilizzata da Gaber® per alcune strutture dei propri prodotti raggiunge una resistenza ottimale agli agenti atmosferici.

### L' Alluminio

Gaber® utilizza l'alluminio per realizzare le strutture di tavoli, sedie e sgabelli. La finitura per mezzo del trattamento superficiale di anodizzazione, utilizzata in alcuni prodotti, ha lo scopo di aumentarne la resistenza alla corrosione.

**Piccole Accortezze:** sia le superfici metalliche in acciaio che in alluminio devono essere pulite con un panno umido e soffice imbevuto in acqua calda. Per le macchie più ostinate è possibile diluire in acqua del sapone neutro liquido con moderazione. Asciugare sempre dopo la pulizia con un panno morbido. Non usare creme o paste per pulire i metalli, non usare cloro, candeggina o detergenti aggressivi. Non usare paste o spugne abrasive che possano graffiare le superfici metalliche.

### Il legno

I prodotti Gaber® con elementi in legno sono prodotti di accordo con le vigenti normative Europee rispetto alle emissioni di formaldeide.

"Compound-wood" è il particolare materiale utilizzato da Gaber® per la realizzazione dei prodotti Alhambra-Eco ed Epica-Eco. Questo materiale utilizza fibre di legno derivanti dagli stessi processi di produzione con cui Gaber realizza elementi in materiale legnoso. Niente viene sprecato.

**Piccole Accortezze:** Le superfici in legno, essendo un materiale naturale, potrebbero, nel tempo, subire alterazioni di colore con l'utilizzo e con l'esposizione alla luce. Inoltre, per loro natura, tali superfici sono facilmente danneggiabili, alcune piccole impurità e imperfezioni rientrano negli standard di qualità accettati. Le superfici in legno non possono sopportare fonti di calore dirette.

Pulire le superfici in legno con un panno umido e soffice, imbevuto in acqua tiepida. Asciugare immediatamente dopo la pulizia.

### Le imbottiture in poliuretano flessibile

Le imbottiture di alcuni prodotti Gaber® sono realizzate in poliuretano flessibile, stampato a freddo, privo di CFC/HCFC (ODP=0: non contribuisce alla riduzione dello strato di ozono atmosferico), autoestinguento classe 1-IM Uni 9175 / CMHR, seguendo le normative Europee in materia.

### I rivestimenti: tessuti e pelli

Tessuti e Pelli utilizzati da Gaber® appartengono ad un'ampia gamma di colori e trame, tutti scelti tra un range di prodotti testati con l'obiettivo di ottenere le migliori caratteristiche prestazionali, quali la resistenza all'abrasione, allo sfregamento e alla resistenza alla luce artificiale. Sono disponibili categorie di tessuti ignifughi e rivestimenti in finte pelli.

**Piccole Accortezze:** pulire le Pelli con un panno bianco umido di sola acqua. Per la pulizia dei tessuti consultare la scheda tecnica specifica.

## IMBALLI E RICICLO

I nostri imballi sono realizzati con l'obiettivo di ottimizzare trasporti e stoccaggio: sono realizzati per il 90% di materiali riciclati e totalmente riciclabili. L'ottimizzazione dell'imballo in termini di volume e peso comporta un minore dispendio di energia, con un conseguente risparmio nei costi di trasporto e un importante aiuto alla salvaguardia del nostro Ambiente Naturale. È consigliabile lo smaltimento degli imballi solo a completamento dell'assemblaggio, onde evitare lo smarrimento di eventuale ferramenta e componenti. Una volta dismesso, il prodotto o i suoi componenti vanno conferiti ai sistemi pubblici di smaltimento secondo quanto previsto dalla legislazione locale in vigore.

## USO IMPROPRIO DEI PRODOTTI

Sono da considerarsi usi impropri e/o scorretti del prodotto il salire in piedi su tavoli, sedie, sgabelli, poggiapiedi, sedersi su schienali, braccioli, utilizzare i prodotti come scaletta. Evitare oscillazioni che potrebbero pregiudicare il funzionamento e la sicurezza dell'utente. Per sollevare o spostare un prodotto non afferrare sotto il sedile, bensì afferrare saldamente la struttura portante. Il prodotto non deve essere sottoposto a carichi decentrati, è stato progettato per essere utilizzato in condizioni normali di appoggio (su quattro gambe o sulla base). Gaber® declina ogni responsabilità per danni causati a cose o a persone derivanti da uso non corretto del prodotto; l'azienda inoltre si solleva da ogni responsabilità per danni provocati su pavimenti e superfici delicate o tenere.



## CONDICIONES GENERALES DE VENTA

- Todos los precios son en Euro (IVA no incluido)
- Portes: debidos (ex-works)
- Toda la mercancía viaja por cuenta y riesgo del comprador.
- Cantidad mínima por cada pedido: igual al embalaje o múltiplo de lo mismo, a menos que se especifique lo contrario. El primer empaque para cada modelo debe estar completo, los paquetes incompletos tendrán un coste adicional de € 6,00 netos.
- Valor mínimo de pedido: € 500,00 netos. Para pedidos inferiores, excepcionalmente aceptados, y del valor mínimo de € 200,00 netos hay un coste fijo extra de € 25,00 netos.
- Los plazos de entrega son indicativos, excepto si lo mismos han sido establecidos por parte de nuestra empresa. En caso de retraso en la entrega no se aceptan cancelaciones de pedidos o peticiones de reembolso.
- La mercancía vendida con pago diferido, se entrega con derecho de reserva de propiedad hasta el pago total de la misma.
- Para cualquier queja, el foro de competencia es el de Treviso, Italia.
- No se admiten reclamaciones efectuadas con posterioridad a los 8 días de la entrega de la mercancía.
- Gaber se reserva el derecho de poder modificar o mejorar sus productos sin previo aviso.

## DOCUMENTACION GABER®

Toda la documentación Gaber® contiene una serie de informaciones técnicas y consejos para el utilize para quién quiera comprar o para quién posea productos pertenencias a la gama Gaber®. En el interés de los clientes, Gaber® se reserva el derecho de poder modificar o mejorar sus productos sin avisar antes.

Los dibujos, las medidas, los materiales y los colores se ilustran exclusivamente a modo de ejemplo y son indicativas, sujetos a tolerancias. Las tonalidad de los colores del muestrario relativas a las telas, pieles, pintura, esencias de las maderas, pueden variar según partida.

Gaber® declina todo tipo de responsabilidades con relación a pequeñas diferencias de color. Gaber® se reserva además el derecho de retirar, suspender o cesar la producción de cualquier producto en cualquier momento y a propia discreción sin dar previo aviso.

Todos los derechos de reproducción, incluso parcial, de los catálogos y listas de precios Gaber® relativos a los textos, imagines, ilustraciones, diseños ya sea por medios mecánicos o electrónicos, incluyendo el fotocopiado o la formación de fuentes de información, sin el permiso previo por escrito de Gaber®, son reservados a nivel mundial.

## MATERIALES, USO Y MANTENIMIENTO

### Material Plástico

Tecno Polímeros compuestos que Gaber® utiliza en sus productos se caracterizan por una alta resistencia estructural, al calor y una alta resistencia a la abrasión. Los Tecno Polímero de Gaber® no son tóxicos, son resistentes a manchas, antiestáticos y UV-resistente: gracias a esto los materiales tienen una excelente resistencia a los agentes atmosféricos. Todos estos materiales son reciclables en el pleno respeto de nuestro medio ambiente. Gaber® produce plástico inyectado sin productos químicos y materiales añadidos y, cuando sea posible, tecnopolímero reciclados se obtienen como materia prima básica, recuperado de post-consumo.

Pequeñas atenciones a: Para mantener los productos de tecnopolímero de Gaber en perfectas condiciones y garantizar una calidad duradera de las materias primas, recomendamos seguir unas instrucciones de cuidado muy básicas. Consejos de limpieza: Las superficies de tecnopolímero generalmente deben limpiarse con un paño normal y agua tibia; para las manchas más persistentes se puede utilizar una pequeña cantidad de jabón líquido diluido en agua. Recomendamos evitar estrictamente todo tipo de sustancias abrasivas, como, por ejemplo, productos de limpieza en polvo, cremas, estropajos y esponjas rugosas. Los productos de tecnopolímero de Gaber se pueden desinfectar con diferentes sustancias. Para obtener más información, consulte en la web "compatibilidad de resistencia a productos químicos de polipropileno"; el uso de estas sustancias también depende de la temperatura, presión y concentración. Siempre es una buena práctica, después de desinfectar los productos de tecnopolímeros con estas sustancias, enjuagar inmediatamente los productos con agua. Cualquier fracción de líquido sobre el producto debe ser borrado de inmediato. Incluso los productos hechos especialmente para el exterior podrían ser afectados por los agentes atmosféricos. Productos podrían someterse a posibles cambios en la exposición especial al calor, la humedad y la salinidad. En casos excepcionales y para una vida larga, los productos podrían cambiar de tonalidad y sombra, si se expone a fuerte luz solar directa. Un mantenimiento y limpieza adecuada y frecuente de los productos aumenta su durabilidad. Mantenimiento tiene que llevarse a cabo por personal de experiencia.

Los tapones de los productos Gaber® están hechos de un compuesto de goma de alta resistencia al desgaste, que reduce el ruido de arrastre. Algunos productos Gaber® están equipados con tapones con fieltro, adecuados para suelos duros y más delicados.

Gaber® fabrica sobre pedido algunos productos de su colección con tecno polímero retardante de fuego: los aditivos que hacen que el producto de plástico sean a prueba de fuego pueden variar sustancialmente la estética y la durabilidad del producto.

### Acero

Acero de alta resistencia se utiliza para producir las estructuras de las sillas y de las mesas, utilizando tubos cuadrados o redondos, así como barilla sólida. Los productos están disponibles en cromo o acabados pintados. La pintura en polvo epoxi especial, utilizada en muchas estructuras Gaber®, logra una excelente resistencia a los agentes atmosféricos.

### Aluminio

Gaber® utiliza aluminio, ligero y resistente, para producir estructuras para las sillas y las mesas. Superficies de aluminio pueden ser anodizado, y Gaber® utilizan este tratamiento especial con el fin de aumentar la resistencia a la corrosión.

Pequeñas atenciones a: tanto las superficies de aluminio que acero se deben limpiar con un paño normal y agua tibia. Para las manchas más persistentes se puede usar una pequeña cantidad de jabón líquido suave diluido en agua. Cualquier fracción de líquido sobre el producto debe ser borrado de inmediato. Se recomienda evitar todo tipo de cremas abrasivas o pastas, esponjas abrasivas, cloro, lejía o detergentes fuertes.

### Las Maderas

Nuestros artículos de madera se producen de acuerdo con la normativa europea vigente en materia de emisiones de formaldehído de los productos a base de madera. Gaber utiliza materias primas de madera que vienen exclusivamente de la cadena de custodia PEFC de materiales certificados.

Pequeñas atenciones a: artículos de madera, siendo materiales naturales, podrían dañarse fácilmente. Las pequeñas impurezas o imperfecciones están dentro del rango estándar de calidad. Superficies de madera moldeada deben ser limpiadas con un paño y agua. Se recomienda secar inmediatamente después del proceso de limpieza.

### Espumas

Gaber® utiliza en algunos de sus artículos tapizados una espuma de poliuretano inyectada dentro de un molde, toda las espumas no contienen CFC / HCFC (ODP = 0: no contribuyen a la reducción de la capa de ozono de la atmósfera), y son de clase ignífugo 1-IM Uni 9175 siguiendo Normas europeas.

### Revestimientos: Telas y Piel

Gaber® utiliza tela y piel que pertenecen a una amplia gama de colores y diseños, que son todos probados a fin de lograr las mejores prestaciones, entre las que la resistencia a la abrasión y la luz artificial. Telas ignífugas y para exterior, tapicería en eco-piel, también están disponibles.

Pequeñas atenciones a: limpias pieles con un paño suave con agua. Consulte las especificaciones técnicas de limpieza para las telas.

## EMPAQUE Y RECICLABILIDAD

La gama de productos Gaber® está constituida por la mayor parte de elementos completamente reciclables. Nuestros embalajes se escalan con el fin de optimizar los requisitos de almacenamiento y de transporte, que están hechos de 90% materia prima reciclada y son totalmente reciclables. La optimización de los embalajes en términos de volumen y peso ofrece un menor consumo de energía en muchas formas, ayudando al medio ambiente y el consiguiente ahorro en los costes de transporte. A fin de evitar la pérdida de componentes, el embalaje debe eliminarse sólo después de completar el montaje de los productos. Una vez que el producto ha sido desmantelado, el propio producto o sus componentes se debe dar a sistema público de reciclaje, de acuerdo con las normas locales.

## USOS INADECUADO DEL PRODUCTO

Evite cualquier uso inadecuado del producto; no subir/caminar sobre el producto, no se pare en el reposapiés o en los brazos, no sentarse en el espaldar o en el reposabrazos, no utilice la silla como una escalera. El producto no debe ser sometido a pesos desequilibrados, ya que está diseñado para un descanso adecuado en el punto de apoyo (en cuatro patas o en la base). Cuando levante o mueva el producto, manténgalo en la estructura principal y no sólo bajo el asiento. Gaber® aceptará ninguna responsabilidad por los daños y perjuicios causados a bienes o personas posteriores a un manejo incorrecto o inadecuado del producto. Gaber® se libera de cualquier responsabilidad en caso de daños causados a los suelos frágiles.

## CONDITIONS GENERALES DE VENTE

- Les prix sont en Euro (H.T.).
- Marchandise vendue départ usine.
- La marchandise voyage sous la responsabilité du client.
- Commande minimum: nous demandons de respecter le colisage indiqué et ses multiples, sauf en cas de confirmation explicite de notre part. Le premier colisage pour chaque modèle doit être complet, tout décolisage exceptionnel sera suivi d'un surcot de € 6,00 net.
- Minimum de commande € 500,00 net achat H.T. Pour toute commande acceptée exceptionnellement inférieure à ce montant et de tout façon non inférieure à € 200,00, nous ajouterons € 25,00 de frais fixe.
- Les délais de livraison sont indicatifs, sauf en cas de confirmation explicite de notre part. Tout retard n'est pas imputable et ne pourra pas donner lieu à une demande de dédommagement ou à l'annulation de la commande en cours.
- Gaber se réserve le droit de propriété sur la marchandise en cas de paiement échelonné, tant que la dernière échéance n'a pas été honorée.
- Pour toute contestation, le tribunal de compétence sera Treviso, Italia.
- Tous dommages ou manquants doivent être signalés par mail ou fax dans les 8 jours qui suivent la livraison.
- Gaber se réserve le droit de modifier ses modèles, à n'importe quel moment, sans aucun préavis.



## DOCUMENTATION GABER®

Notre documentation contient des informations techniques et des conseils pour l'utilisation des produits, pour les futurs clients Gaber® ou pour qui est déjà en possession d'un produit Gaber®. Dans l'intérêt de la clientèle, Gaber® se réserve le droit de modifier ses modèles, à n'importe quel moment, sans aucun préavis.

Les dessins, les descriptions, les cotes, les matériaux et les couleurs du catalogue et du tarif sont purement indicatifs et sous réserve des tolérances. Les dimensions en pouce sont indicatives. Les tonalités des couleurs qui sont représentées sur la carte couleur, relatives aux tissus, au cuir, aux polipros, aux essences de bois sont purement indicatives car elles peuvent varier d'un lot à un autre. Gaber® décline toute responsabilité en ce qui concerne toute différence de tonalité.

Gaber® se réserve le droit de retirer, de suspendre ou de cesser la production de tout article, sans aucun préavis. Tout droit de reproduction, même partielle, des catalogues, relatif aux textes, images, illustrations, dessins, par des moyens mécaniques, électroniques, par photocopie, ou autre source d'information, sans le consentement préalable de Gaber®, est réservé.

## MATERIAUX UTILISES ET LEUR ENTRETIEN

### Matière plastique

Les billes de technopolymère utilisées par Gaber® pour fabriquer ses produits ont les caractéristiques suivantes : résistance structurelle thermique et à l'abrasion. Le technopolymère est non toxique, il est anti statique et anti UV ; ces qualités le rendent très résistant aux agents atmosphériques. Le technopolymère est entièrement recyclable, dans le respect de la charte écologique.

Quelques informations pour l'entretien : pour maintenir les produits techno-polymères Gaber dans des conditions parfaites et garantir une qualité durable des matières premières, nous recommandons par la présente des instructions d'entretien très basiques à suivre. Conseils de nettoyage: Les surfaces en technopolymère doivent généralement être nettoyées avec un chiffon normal et de l'eau tiède; pour les taches les plus tenaces, une petite quantité de savon liquide dilué dans l'eau peut être utilisée. Nous vous recommandons d'éviter strictement tous les types de substances abrasives, comme par exemple les produits de nettoyage en poudre, les crèmes, les tampons de score et les éponges rugueuses. Les produits technopolymères de Gaber peuvent être désinfectés à l'aide de différentes substances, pour plus d'informations, consultez le site Web «Compatibilité de résistance aux produits chimiques du polypropylène»; l'utilisation de ces substances dépend également de la température, de la pression et de la concentration. C'est toujours une bonne pratique, après avoir désinfecté les produits technopolymères avec ces substances, rincer immédiatement les produits à l'eau. Le liquide versé sur un plateau doit être immédiatement essuyé, les articles réservés à un usage externe peuvent subir à la longue l'action d'agents atmosphériques, tels que la salinité, l'humidité, les rayons de soleil, qui peuvent en altérer la superficie et la couleur. Nous recommandons un entretien régulier ainsi qu'un nettoyage correcte et fréquent, ce qui augmentera la durée de vie du produit. L'entretien doit être effectué par des personnes expertes.

Les bouchons des produits Gaber® sont faits d'un composé en caoutchouc à haute résistance d'usure, qui réduit aussi le bruit de trainée. Certains produits Gaber® sont équipés de bouchons avec feutre, adaptés aux sols durs et plus délicats.

Gaber® réalise sur demande, certains articles de sa collection, en polymère "ignifugé"; cependant les additifs qui rendent le produit plastique "ignifugé" peuvent en varier l'esthétique et la résistance.

### Acier

L'acier utilisé pour la fabrication des structures de tables, chaises, et tabourets Gaber® est très résistant. Il est travaillé sous forme de tube à section carrée ou ronde. La finition peut être chromée ou vernis. Le vernissage spécial à époxy, utilisé par Gaber®, a une résistance optimale aux agents atmosphériques.

### Aluminium

L'aluminium anodisé utilisé pour la réalisation de structures de tables, chaises et tabourets augmente la résistance à la corrosion. Conseil d'entretien pour les surfaces en acier et/ou en aluminium: nettoyer avec un chiffon doux, humide, imprégné d'eau chaude. Pour les taches éventuelles, on peut ajouter un peu de détergent à usage domestique. Il est recommandé de bien sécher la surface ensuite. Il ne faut pas utiliser de pâte et/ou crème pour métal, il ne faut pas utiliser de chlore, de javel ou autre détergents agressifs. Il ne faut pas utiliser de pâte ou d'éponges abrasives, qui pourraient endommager les rayants, les superficies.

### Bois

Les articles Gaber® avec bois, sont fabriqués selon les normes européennes en vigueur, sans formaldéhyde. (par rapport à l'émission de formaldéhyde). Le matériel utilisé pour la fabrication des articles ALHAMBRA ECO et EPICA ECO est un mélange de sciure de bois rendu compact et dérivant de matériel recyclé. Il n'y a ainsi aucun gaspillage. Le bois étant une matière naturelle, peut, avec le temps et suivant l'exposition à la lumière, subir de légères modifications au niveau de la couleur. Ces produits, de par leur nature, peuvent s'abîmer facilement ; nous tenons aussi à préciser que certaines imperfections correspondent à un standard normal de qualité. Il est recommandé enfin, de ne pas approcher la superficie à une source de chaleur directe. Les superficies se nettoient à l'aide d'un chiffon doux, légèrement humide. Sécher toujours ensuite.

### Rembourrage en polyuréthane « flexible »

Le rembourrage de certains articles Gaber® est réalisé en polyuréthane « flexible », injecté à froid, sans particules de CFC/HCFC (ODP=0, ne réduit pas la couche d'ozone), ignifugé en classe 1-IM UNI 9175 / CMHR, selon les normes européennes en vigueur.

### Revêtement : tissus et cuir

Gaber® a au choix une large gamme de couleurs et de trames, choisis parmi des tissus, des cuirs, des ecopelle testés et garantissant une bonne résistance aux frottements, aux abrasions, à la lumière artificielle. Nous avons aussi une gamme de revêtements non feu.

Informations et entretien : nettoyer les peaux avec un chiffon blanc, légèrement humide. Pour l'entretien des tissus, consulter la fiche technique, spécifique.

## EMBALLAGE ET RECYCLAGE

Nos emballages sont conçus de façon à optimiser le transport et le stockage ; ils sont réalisés à 90% avec du matériel recyclé et sont complètement recyclables. L'emballage, optimisé au maximum en ce qui concerne son volume et son poids, permet une économie d'énergie, de main d'œuvre et de coût de port, sans oublier la sauvegarde de notre environnement. Il est vivement conseillé de monter complètement l'article Gaber® avant de procéder à l'élimination du carton, ceci, afin d'éviter de perdre la visserie et / ou les divers composants de l'article en question.

Lorsqu'un produit Gaber® arrive en fin de vie, il est recommandé de porter les diverses parties qui le compose à la déchèterie, selon la loi du pays en vigueur

## USAGE INCORRECT DES PRODUITS

Les tables, chaises, tabourets ou repose pieds ne sont pas fait pour monter dessus, il ne faut pas s'asseoir sur les dossiers ou les accoudoirs ou se servir de ces articles comme d'un escabeau. Il faut éviter de se balancer d'avant en arrière sur les assises, de façon à éviter les accidents. Pour soulever ou déplacer une chaise ou tabouret, il est recommandé de le prendre par le châssis et non par l'assise. Le produit ne doit pas être soumis à des charges excessives ou décentrées, il a été conçu pour un usage normal de simple appui (sur 4 pieds ou sur pied central).

Gaber® décline toute responsabilité pour les dommages causés à personne ou choses, qui pourraient dériver d'un usage incorrect du produit. L'usine décline aussi toute responsabilité pour les dommages sur parquets ou sol délicats.



## ALLGEMEINE VERKAUFSBEDINGUNGEN

- Die Preise werden in Euro ausgedrückt (MwSt. ausgeschlossen)
- Die Rückgabe der Ware erfolgt ab Werk
- Die Ware reist auf Gefahr des Auftraggebers
- Sofern nicht anders angegeben, entspricht die Mindestbestellmenge der Verpackung bzw. mehrfachen dergleichen. Die erste Verpackung muss vollständig sein. Für andere unvollständige Verpackungen wird ein Aufpreis von € 6,00 angerechnet.
- Der Mindestnettoertrag der Bestellung beträgt € 500,00. Bestellungen mit niedrigeren Beträgen werden ausnahmsweise angenommen. Jedenfalls dürfen diese den Nettobetrag von € 200,00 nicht unterschreiten und es werden zusätzlich Fixkosten in Höhe von € 25,00 angerechnet.
- Die Lieferzeiten gelten als reine Orientierung. Bei Verspätungen können keine Schadensersatzansprüche geltend gemacht oder die Bestellung storniert werden.
- Ein Zahlungsaufschub wird unter Eigentumsvorbehalt der Ware bis zur vollständigen Bezahlung gewährt.
- Für eventuelle Streitigkeiten oder Auseinandersetzungen ist das Forum von Treviso (Italien) zuständig.
- Eventuelle Beschwerden müssen innerhalb von 8 Tagen ab Erhalt der Ware mitgeteilt werden.
- Gaber behält sich das Recht Änderungen und Verbesserungen an der Ware, auch ohne Vorankündigung, vorzunehmen.



## GABER® DOKUMENTATION

Die Dokumentation von Gaber® beinhaltet technische Informationen und Ratschläge zur Nutzung von Gaber® Produkte für Kaufinteressenten bzw. für Besitzer von Artikeln, die zur Produktpalette der Gaber® angehören. Im Interesse der Kunden behält sich Gaber® das Recht vor die eigenen Modelle jederzeit abzuändern, ohne Pflicht zur Vorankündigung. Die Zeichnungen, die Quoten, die Materialien und die Farben der Kataloge und der Preislisten der Gaber® dienen lediglich als Information und unterliegen Toleranzen. Die Maßen, die in Zoll angegeben sind, sind als Richtwerte zu betrachten. Die dargestellten Farbtöne, auch die in den Farbpaletten, sowie die Stoff-, Leder-, Lack-, Glas- und Holzverkleidungen sind Indikativ, da von Fall zu Fall Änderungen möglich sind. Gaber® lehnt jegliche Verantwortung in Verbindung mit Farbtonabweichungen ab. Gaber® behält sich zudem das Recht vor die Produktion jedes einzelnen Produkts zurückzuziehen, einzustellen bzw. abzutreten. Die Rechte an der Reproduktion von Kataloge und Preislisten der Gaber® in Bezug auf Texte, Bilder, Illustrationen, Zeichnungen, die sowohl mit mechanischen als auch mit elektronischen Mitteln, Kopien inbegriffen, erfolgen sind weltweit der Gaber® vorbehalten und benötigen eine schriftliche Genehmigung der Gaber®.

## VERWENDETE MATERIALIEN UND WARTUNG

### Kunststoffmaterialien

Die von Gaber® benutzte „Technopolymer-Verbindung“ für die Realisierung der eigenen Produkte sind durch hohe strukturelle, thermische und abriebfeste Resistenz gekennzeichnet. Das „Technopolymer“, welcher Bestandteil der Produkte Gaber® ist, ist ungiftig, schmutzabweisend, antistatisch und anti-UV: Eigenschaften, die der Produkte Gaber® eine optimale Resistenz gegen die atmosphärischen Einflüsse verleiht. Die verwendeten „Technopolymer“ sind, in Beachtung der Umwelt, vollständig recycelbar. Gaber® produziert thermoplastische Artikel ohne chemische Zusätze und, wo möglich, wird recyceltes „Technopolymer“ aus wiederverwendeten Altstoffen benutzt.

Richtlinien für die korrekte Verwendung: Richtlinien für die korrekte Verwendung: Um die Technopolymerprodukte von Gaber während der gesamten Zeit in einwandfreiem Zustand zu halten und eine lang anhaltende Qualität der Rohstoffe zu gewährleisten, empfehlen wir hiermit grundlegende Anweisungen zur Pflege. Reinigungshinweise: Technopolymeroberflächen müssen normalerweise mit einem normalen Tuch und warmem Wasser gereinigt werden. Für die hartnäckigsten Flecken kann eine kleine Menge in Wasser verdünnter Flüssigseife verwendet werden. Wir empfehlen, alle Arten von Schleifmitteln, wie z. B. pulverförmige Reinigungsprodukte, Cremes, Scorepads und grobe Schwämme, strikt zu vermeiden. Gabers Technopolymerprodukte können mit verschiedenen Substanzen desinfiziert werden. Weitere Informationen finden Sie im Internet unter „Verträglichkeit der Beständigkeit gegen Polypropylen-Chemikalien“. Die Verwendung dieser Substanzen hängt auch von der Temperatur, dem Druck und der Konzentration ab. Es ist immer eine gute Praxis, nach dem Desinfizieren der Technopolymerprodukte mit diesen Substanzen die Produkte sofort mit Wasser zu spülen. Es sollte zudem nicht mit Schleif- bzw. Lösungsmittel in Kontakt treten oder mit grobe Reinigungsgeräte. Die auf die Produkte Gaber® verschütteten Flüssigkeiten müssen sofort abgetrocknet werden. Produkte, die für den Außenbereich bestimmt sind, erleiden mit der Zeit die wetterbedingten Einwirkungen. Eventuelle oberflächliche Änderungen können aufgrund bestimmter Temperatur-, Feuchtigkeits- oder Salzgehaltsbedingungen auftreten. Eine direkte Sonneneinstrahlung kann eine Farbänderung des Produktes verursachen. Eine korrekte und regelmäßige Wartung erhöht die Haltbarkeit des Produkts. Wartungsmaßnahmen sollten von einem spezialisierten Personal vorgenommen werden. Die Kappen und Schutzvorrichtungen der Gaber®-Produkte sind in einer Gummimischung mit hoher Verschleißfestigkeit gemacht, zur Reduzierung von Schleppgeräuschen. Einige Gaber®-Produkte sind Filzstöpseln ausgestattet, die für starre und empfindlichere Böden geeignet sind.

Gaber® realisiert auf Anfrage einige Produkte der eigenen Kollektion mit feuerfesten „Technopolymer“: die Zusatzstoffe, die das Kunststoffmaterial feuerfest machen, können die Ästhetik und die Resistenz der Produkte grundlegend verändern.

Die Kappen und Schutzvorrichtungen der Gaber-Produkte sind in einer Gummimischung mit hoher Verschleißfestigkeit gemacht, zur Reduzierung von Schleppgeräuschen. Einige Gaber-Produkte sind Filzstöpseln ausgestattet, die für starre und empfindlichere Böden geeignet sind.

### Der Stahl

Bei den Strukturen von Tischen, Stühlen und Hockern wird hochfester Stahl verwendet, diese werden von Gaber® mittels rund- bzw. quadratförmige Röhre realisiert. Die Produkte sind in verchromter oder lackierter Ausführung erhältlich. Die spezielle Lackierung aus Epoxidpulver, die von Gaber® an vielen Strukturen verwendet wird, erreicht eine optimale Resistenz gegen die atmosphärischen Einflüsse.

### Das Aluminium

Gaber® benutzt das Aluminium für die Realisierung der Strukturen von Tischen, Stühlen und Hockern. Mittels einer speziellen Verarbeitung der Oberflächen einiger Produkte Gaber®, des Anodisierens, wird die Korrosionsresistenz erhöht. Richtlinien für die korrekte Verwendung: sowohl die Stahl- als auch die Aluminiumoberflächen müssen mit einem feuchten und weichen Tuch, durchtränkt in heißem Wasser, gereinigt werden. Für die hartnäckigsten Flecken kann man mit Vorsicht eine neutrale flüssige Seife in Wasser verdünnen. Nach der Reinigung sollte die Oberfläche immer mit einem weichen Tuch abgetrocknet werden. Verwenden Sie keine Cremes oder Pasten um die Metalle zu reinigen, sowie kein Chlor, Bleichmittel oder sonstige aggressive Reinigungsmittel. Benutzen Sie auch keine groben Pasten oder schleifende Schwämme, die die Metalloberflächen verkratzen könnten.

### Das Holz

Die Produkte Gaber® mit Holzelemente werden in Übereinstimmung mit den geltenden europäischen Vorschriften bezüglich der Emission von Formaldehyd hergestellt. „Compound-Wood“ ist das besondere Material, das von Gaber® für die Realisierung der Produkte „Alhambra-Eco“ und „Epica-Eco“, verwendet wird. Dieses Material benutzt die Holzfasern aus dem Produktionsprozess, mit welchem Gaber® die Holzelemente herstellt. Es wird nichts verschwendet. Richtlinien für die korrekte Verwendung: Die Holzoberfläche kann mit der Zeit durch die Benutzung oder die Sonneneinstrahlung eine Farbänderung erleiden, da es sich um ein natürliches Material handelt. Zudem sind die Oberflächen, aufgrund Ihrer Natur, leicht zu beschädigen. Einige kleine Unreinheiten und Macken liegen im annehmbaren Qualitätsstandard. Die Holzoberflächen vertragen keine direkte Wärmezufuhr. Reinigen Sie die Holzoberflächen mit einem feuchten und weichen Tuch, durchtränkt in lauwarmes Wasser. Trocknen Sie das Produkt sofort nach der Reinigung.

### Polsterung in flexibles Polyurethan

Die Polsterung einiger Produkte von Gaber® besteht aus flexiblem Polyurethan, kaltgepresst, ohne CFC/HCFC (ODP=0: es trägt nicht zur Reduzierung der atmosphärischen Ozonschicht bei), selbstlöschend der Klasse 1-IM UNI 9175/CMHR, gemäß der geltenden europäischen Vorschriften.

### Die Bezüge: Stoffe und Leder

Gaber® verwendet Stoffe und Leder, die zu einer umfassenden Palette an Farben und Mustern gehören, die alle aus einer Reihe getesteter Produkte ausgewählt wurden, mit dem Ziel die beste Leistung wie die Abriebfestigkeit und Resistenz gegen künstliches Lichtes zu erzielen. Es sind Kategorien feuerfester Stoffe und künstliche Lederbezüge erhältlich. Richtlinien für die korrekte Verwendung: Reinigen Sie das Leder mit einem weißen Tuch, der nur mit Wasser befeuchtet werden sollte.

## VERPACKUNG UND RECYCLING

Unsere Verpackungen wurden mit dem Ziel realisiert den Lager und Transport zu optimieren. Sie bestehen zu 90% aus recycelten Materialien und sind vollständig recycelbar. Die Optimierung der Verpackung in Bezug auf Volumen und Gewicht führt zu einem geringeren Energieverbrauch, mit einer folgenden Einsparung bei den Transportkosten und einer wichtige Hilfe zum Schutz der Umwelt. Um den Verlust von Bauteilen zu vermeiden, wird es empfohlen die Verpackung erst nach Abschluss der Montage der Produkte zu entsorgen. Nach der Montage kann das Produkt oder seine Bestandteile dem öffentlichen Entsorgungssystem gemäß den geltenden örtlichen Vorschriften übergeben werden.

## UNSACHGEMÄSSE VERWENDUNG DES PRODUKTS

Als eine unpassende bzw. unkorrekte Verwendung des Produkts wird folgendes angesehen: auf Tische, Stühle und Hockern aufstehen, auf Rücken- und Armlehnen niedersetzen, die Produkte als Treppchen zu nutzen. Das Schwenken des Produktes könnte das Produkt oder dessen Funktion beschädigen und die Sicherheit des Nutzers gefährden. Um das Produkt anzuheben oder zu verschieben wird empfohlen es an der Hauptstruktur und nicht unter dem Sitz zu halten. Das Produkt sollte keiner dezentralen Last ausgesetzt sein, da es für die Nutzung in normalen Konditionen geplant wurde. Gaber® übernimmt keine Haftung für Schäden an Sachen oder Personen, die durch unsachgemäße Verwendung des Produkts verursacht wurden. Gaber® lehnt zudem jede Haftung für Schäden an empfindlichen Böden oder Oberflächen ab.

# CONTENTS / INDICE CHAIRS

DAME P.96

Forsix Design



CUCARACHA P.93

Favaretto & Partners Design

[NEW]



MANAA P.164

Studio Eurolinea Design



CHOPPY P.79 CHEVALET P.78

Favaretto & Partners Design

Favaretto & Partners Design



NUTA LIGHT P.182 KASIA P.157

Favaretto & Partners Design

[NEW] Forsix Design

[NEW]



# CHAIRS

## FULLER

Marc Sadler Design



## P.118 ARTESIA

Forsix Design



## P.62

[NEW]

## JUBEL

Forsix Design



## P.126

## KANVAS

Stefano Sandonà Design



## P.135

## EPICA

Marc Sadler Design



## P.108 TOGETHER

Marc Sadler Design



## P.215 LILÁ

Forsix Design



## P.160

## NUTA

Favaretto & Partners Design



## P.180 ABUELA

Favaretto & Partners Design



## P.44

# CHAIRS

ISIDORA

Favaretto & Partners Design



P.124 LIBIBET

Forsix Design



P.161

[NEW]

SPYKER

Studio Eurolinea Design



P.210 CLIPPERTON

Marc Sadler Design



P.82

BAKHITA

Studio Eurolinea Design



P.66 MINUSH

Studio Eurolinea Design



P.226 PRISMA

Studio Eurolinea Design



P.196

SANELA

Forsix Design



P.198

[NEW]

AMITHA

Forsix Design



P.58

[NEW]

# CHAIRS

LINK

Stefano Sandonà Design



P.162 AVENICA

Studio Eurolinea Design

P.65

KALIPA

Studio Eurolinea Design



P.134 PANAMA

Stefano Sandonà Design



P.185 BIG BANG

Stefano Sandonà Design



P.75

BLOG

Stefano Sandonà Design



P.76 AKAMI

Stefano Sandonà Design



P.46



COLORFIVE

Stefano Sandonà Design



P.85 ALHAMBRA

Stefano Sandonà Design



P.53



SLOT

Favaretto & Partners Design



P.201

# CHAIRS

BASKET

Forsix Design



P.68 MOEMA

Forsix Design



P.170

MORE

Favaretto & Partners Design



ELODIE

Marc Sadler Design

P.175 EXTREME

Forsix Design



P.106 TECKEL

Studio Eurolinea Design



P.114 FLAP

Studio Eurolinea Design



P.213 NINJA

Delineo Design

P.116 COMPACT

Studio Eurolinea Design



P.179 PRODIGE

Delineo Design

P.90

HARMONY

Studio Eurolinea Design



P.121 IRIS

Studio Eurolinea Design



P.123 MOON - VENEZIA

Forsix Design



P.174 - 217

OVER

Forsix Design



P.184 LIBERTY

Forsix Design



P.159 OPEN

Forsix Design



P.183 SERENA

Forsix Design



P.200



# CHAIRS

MAYA

Forsix Design



P.168 TULIP

Forsix Design



P.216 BEVERLY

Forsix Design



P.74

## LOUNGE SEATING, SOFAS, POUF

SANELA

Forsix Design



P.198

[NEW]

AMITHA

Forsix Design



P.60

[NEW]

LINK

Stefano Sandonà Design



P.162 SUNLOUNGER

Forsix Design



P.211

# LOUNGE SEATING, SOFAS, POUF

MINUSH RELAX

P.169

GRAND MINUSH

P.120

CONGA

P.91

Studio Eurolinea Design

Studio Eurolinea Design

Studio Eurolinea Design



ETESIAN

Forsix Design

P.110

[NEW]



SOCIAL-IZE

P.209

PANKY

P.187

Studio Eurolinea Design

Forsix Design



PLACE

Favaretto & Partners Design

P.193



EALA

Forsix Design

P.104 KANVAS LOUNGE

[NEW] Stefano Sandonà Design

P.156





# LOUNGE SEATING, SOFAS, POUF

## SLOT LOUNGE

Favaretto & Partners Design

## P.208 ABUELA LOUNGE

P.45

Favaretto & Partners Design



## CUCARACHA

Favaretto & Partners Design

## P.93 FINFERLO

P.115

[NEW] Favaretto & Partners Design



# STOOLS

NUTA LIGHT

Favaretto & Partners Design



P.272 KASIA

[NEW] Forsix Design



P.257

[NEW]



SANELA

Forsix Design



P.281 AMITHA

[NEW] Forsix Design



P.227 LINK

Stefano Sandonà Design



P.262

ABUELA

Favaretto & Partners Design



P.220 NUTA

Favaretto & Partners Design



P.271

ISIDORO

Favaretto & Partners Design

P.247 BAKHITA

Studio Eurolinea Design



P.231 SPYKER

Studio Eurolinea Design



P.288

FULLER

Marc Sadler Design



P.245 JUBEL

Forsix Design



P.250



# STOOLS

KANVAS

Stefano Sandonà Design



P.254 ARTESIA

Forsix Design



P.228



COLORFIVE

Stefano Sandonà Design



P.235 ALHAMBRA

Stefano Sandonà Design



P.223 PRODIGE

Delineo Design



P.278

BLOG

Stefano Sandonà Design



P.232 AKAMI

Stefano Sandonà Design



P.221 MOEMA

Stefano Sandonà Design



P.268

[NEW]



MORE

Favaretto & Partners Design



P.269 MANAA

Studio Eurolinea Design



P.263 DAME

Forsix Design



P.238

[NEW]



SLOT

Favaretto & Partners Design



P.283 PANAMA

Stefano Sandonà Design



























P.276 KALIPA

Studio Eurolinea Design



P.253

# STOOLS

EASY Studio Eurolinea Design	P.240 LILÁ Forsix Design	P.260 SHIVER Studio Eurolinea Design	P.282 ROLLER Studio Eurolinea Design	P.280
				
MOEMA Stefano Sandonà Design	P.267 OCTO Stefano Sandonà Design	P.273 FREEDOM Stefano Sandonà Design	P.244 RITMO Forsix Design	P.279 FORMAT Forsix Design
				
MAX Forsix Design	P.265 CROSS Forsix Design	P.237 SWING - TORINO Stefano Sandonà Design	P.290 - 292	P.289 SQUARE Forsix Design
				
MICRO Studio Eurolinea Design	P.266 OVER Forsix Design	P.275 ASOLO Forsix Design	P.230 SNACK · CITRO Forsix Design	P.287-234
				
FIX · TOM · JOY Studio Eurolinea Design	P.241-291-249	P.241-291-249	GULIVER · FREE Forsix Design	P.246-243
				

# STOOLS

LIBERTY

P.259

OFER

P.274

Forsix Design

Forsix Design



# TABLES

## COFFEE TABLES\_H35/50

<b>TAG</b>		<b>P.357</b>	<b>SURFY</b>		<b>P.355</b>	<b>SURFY</b>		<b>P.356</b>
Ilaria Marelli Design		<b>[NEW]</b>	Studio Eurolinea Design			Studio Eurolinea Design		



<b>STEFANINO</b>	<b>P.345</b>	<b>STEFANO 3-POD</b>	<b>P.344</b>	<b>WOODY</b>	<b>P.361</b>	<b>SATURNINO</b>	<b>P.339</b>	<b>ROLLER</b>	<b>P.333</b>
Studio Eurolinea Design		Studio Eurolinea Design		Favaretto & Partners Design		Studio Eurolinea Design		Studio Eurolinea Design	



<b>ARKET</b>	<b>P.296</b>	<b>LOL3</b>	<b>P.318</b>	<b>LINK</b>	<b>P.317</b>	<b>SIMPLY</b>	<b>P.340</b>	<b>MINUSH</b>	<b>P.322</b>
Studio Eurolinea Design		Forsix Design		Stefano Sandonà Design		Studio Eurolinea Design		Studio Eurolinea Design	



<b>CLARO</b>	<b>P.303</b>	<b>CLARO SLIM</b>	<b>P.306</b>
Studio Eurolinea Design		Studio Eurolinea Design	



# TABLES

## HIGH TABLES\_H100/110

SURFY HIGH DESK 2027	P.353	STEP	P.346	FORMAT	P.310	BANKET	P.300	ICS	P.315
Studio Eurolinea Design		Studio Eurolinea Design		Studio Eurolinea Design		Studio Eurolinea Design		Studio Eurolinea Design	



AZIONE	P.299	CLARO SLIM	P.308	SIMPLY	P.340	TOGETHER	P.360	NORMAN	P.324
Forsix Design		Studio Eurolinea Design		Studio Eurolinea Design		Marc Sadler Design		Forsix Design	[NEW]



GLITTER	P.311	ARKET	P.296	LEI	P.400	TKITT	P.363	TATAMI	P.409
Forsix Design	[NEW]	Studio Eurolinea Design		Studio Eurolinea Design		Studio Eurolinea Design		Studio Eurolinea Design	































SERIE R	P.403 - 404	SERIE Q	P.405 - 406	ROLLER	P.336
Studio Eurolinea Design		Studio Eurolinea Design		Studio Eurolinea Design	



# TABLES

## TABLES\_H74

APRIO Forsix Design	P.295 <b>[NEW]</b>	CLARO Studio Eurolinea Design	P.303	CLARO SLIM Studio Eurolinea Design	P.307
					
SIMPLY Studio Eurolinea Design	P.340	ROLLER Studio Eurolinea Design	P.336	MUG Studio Eurolinea Design	P.323
					P.338
SATURNO Studio Eurolinea Design	P.338	TKITT Studio Eurolinea Design	P.363		
					
GLITTER Forsix Design	P.311 <b>[NEW]</b>	ARKET Studio Eurolinea Design	P.296	ARKET PLUS Studio Eurolinea Design	P.298
					
BRISTOL Forsix Design	P.301 <b>[NEW]</b>	LOL Forsix Design	P.318	LOL PLUS Forsix Design	P.319
					
LEI Studio Eurolinea Design	P.213	HUG Studio Eurolinea Design	P.312	AMICA Studio Eurolinea Design	P.215
					P.324
					P.317



# TABLES

## TABLES\_H74

<u>PAREO</u> Studio Eurolinea Design	<u>P.327 AGILE</u> [NEW] Studio Eurolinea Design	<u>P.294 CHARME</u> Studio Eurolinea Design	<u>P.302</u>
---	---	--	--------------



<u>SURFY HUB 2027</u> Forsix Design	<u>P.348 SURFY DESK 2027</u> Forsix Design	<u>P.352 SURFY HUB 2027 OVAL</u> Forsix Design	<u>P.350</u>
--	---	---	--------------



<u>FLIPAWAY</u> Forsix Design	<u>P.309 AZIONE</u> Forsix Design	<u>P.299 FORMAT</u> Studio Eurolinea Design	<u>P.310 PROFILO</u> Studio Eurolinea Design	<u>P.332 SPACE</u> Studio Eurolinea Design	<u>P.341</u>
----------------------------------	--------------------------------------	--	---	---	--------------



<u>STEFANO</u> Studio Eurolinea Design	<u>P.342 TOGETHER</u> Marc Sadler Design	<u>P.359</u>
---	---	--------------



# TABLES

## TKITT COLLECTION

TKITT.BG3K P.365 TKITT.BG3L P.366 TKITT.BG4IP P.369 TKITT.BG4J P.368 TKITT.BG4K P.367



TKITT.BGA3L P.366 TKITT.BGA4K P.367 TKITT.BGPJ P.369 TKITT.BGPK P.368 TKITT.DPBT54 P.372



TKITT.BQAJ P.373 TKITT.BQJ P.373 TKITT.BRK P.372 TKITT.BTAK P.370 TKITT.BTAK54 P.371



TKITT.BTK P.370 TKITT.BTK54 P.371 TKITT.STAKY P.374 TCONT.STADY P.375



# TABLES

## TABLE TOPS

STANDARD COMPACTOP SURFACES	P.376	SPECIAL COMPACTOP SURFACES FULLCOLOR	P.377	SPECIAL COMPACTOP SURFACES 10	P.378	SPECIAL COMPACTOP SURFACES FENIX	P.380	STANDARD LAMINATED SURFACES 22	P.381
-----------------------------	-------	--------------------------------------	-------	-------------------------------	-------	----------------------------------	-------	--------------------------------	-------



STANDARD LAMINATED SURFACES 50	P.382	SPECIAL LAMINATED SURFACES WOOD EFFECT 25	P.383	SPECIAL LAMINATED SURFACES FENIX 25	P.384	IRON SURFACES	P.385	TECHNO POLYMER TABLE TOPS	P.386
--------------------------------	-------	---	-------	-------------------------------------	-------	---------------	-------	---------------------------	-------



# TABLES

## TABLE BASES COLLECTION

ALFIE P.408 AMICA P.402 ARKET PLUS P.389 ARKET 3 P.388



ARKET 4 P.388 BG2J P.395 BG3K - BGA3K P.389 - 390 BG3L - BGA3L P.391



BG4IP P.395 BG4J P.393 BG4K - BGA4K P.392 BGPJ P.394 BGPK P.393



BPG3K P.390 BPG4K P.394 BQAJ - BQJ P.400 - 401 BRCV P.398 BRISTOL P.413



[NEW]

BRK P.399 BTAK - BTK P.396 BTAK54 - BTK54 P.397 D2 P.407 GLITTER P.414



[NEW]

# TABLES

## TABLE BASES COLLECTION

LEI P.400 LOL PLUS P.412 LOL 3 P.410 LOL 4 P.411

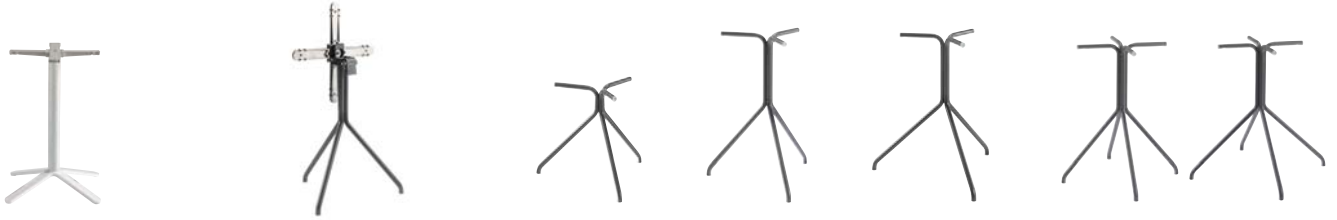

Q1 - Q2 - Q3

P.405 - 406 R1 - R2 - R3

P.403 - 404



T1 FLOOR FIXING

P.405 TATAMI

P.409 V1

P.404 VENUS ROUND

P.398 VENUS SQUARE

P.399



# CABINETS & WORKSTATION

## OFFICE & WORKSPACES SYSTEMS

WORKSTATIONS 2027

P.416

Forsix Design

[NEW]



CABINETS 2027

P.424

Forsix Design

[NEW]



# ACOUSTIC & ACCESSORIES

## DIAMANTE

Studio Eurolinea Design



## P.437 TUNE

Forsix Design



## P.444 PIUMA

Studio Eurolinea Design



## P.442

## STILLY

Studio Eurolinea Design



## P.432 FONO

Marc Sadler Design



## P.433

## MADISON

Studio Eurolinea Design



## P.436 UNIKO

Studio Eurolinea Design



## P.435

## ONDA

Studio Eurolinea Design



## P.448 FLAIRE

Studio Eurolinea Design



## P.450 LUX

Studio Eurolinea Design



## P.451 CULTURE

Malene Flensted  
Urup Design



## P.449 DISPLAY

[NEW] Malene Flensted  
Urup Design



## P.429

## COLORS AND FINISHES P.454



# AWARDS

SUCCESS IN PROGRESS



Gaber has won prestigious awards in the field on innovation and design. These recognitions are a testament to Gaber's unstinting commitment to design and the focus on originality and innovation we bring to the world.

Gaber ha vinto prestigiosi riconoscimenti nel campo dell'innovazione e del design. Questi riconoscimenti sono una testimonianza dell'impegno incondizionato di Gaber per il design e l'attenzione all'originalità e all'innovazione che portiamo al mondo.



**MAGIC**  
2003  
Studio Eurolinea  
Design



**OVER**  
2004  
Studio Eurolinea  
Design



**PRISMA**  
2005  
Studio Eurolinea  
Design



**PRODIGE**  
2007  
Delineo Design



**FLOWER**  
2008  
Laura Tombari  
Design

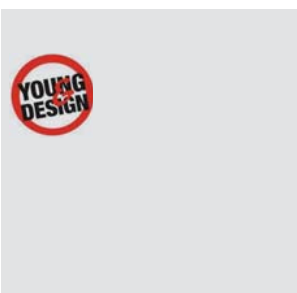

**SPRING**  
2008  
Monica Graffeo  
Design



**EXTREME**  
2009  
Stefano  
Sandonà  
Design



**MOEMA**  
2009  
Stefano  
Sandonà  
Design





AWARDS



**ALHAMBRA**  
2010  
Stefano  
Sandonà  
Design



**FREEDOM**  
2010  
Stefano  
Sandonà  
Design

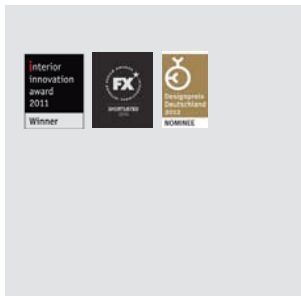

**BIG BANG**  
2011  
Stefano Sardonà  
Sabrina Bettini  
Design



**MOEMA wood**  
2011  
Stefano  
Sandonà  
Design

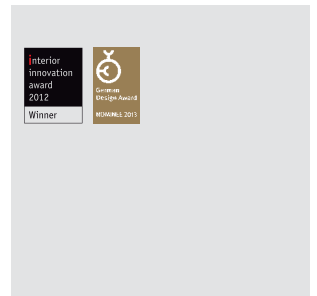

**JOE**  
2011  
Stefano  
Sandonà  
Design



**COLORFIVE**  
2011  
Stefano  
Sandonà  
Design



**TOGETHER**  
2011  
Marc Sadler  
Design



**BLOG**  
2012  
Stefano  
Sandonà  
Design

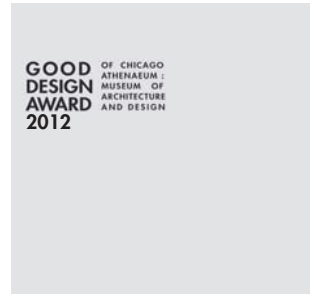

**OCTO**  
2012  
Stefano  
Sandonà  
Design



**MORE**  
2012  
Favaretto &  
Partners Design



**PANAMA**  
2013  
Stefano  
Sandonà  
Design



**AKAMI**  
2013  
Stefano  
Sandonà  
Design

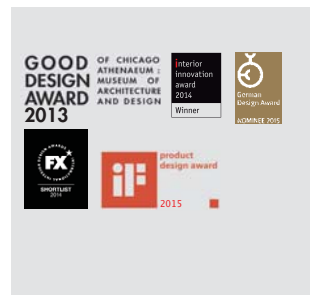

SUCCESS IN PROGRESS



**SLOT**  
2013  
Favaretto & Partners Design



**CHEVALET**  
2013  
Favaretto & Partners Design



**BASKET**  
2013  
Alessandro Busana Design



**EPICA**  
2014  
Marc Sadler Design



**STILLY**  
2014  
Studio Eurolinea Design



**ISIDORA ISIDORO**  
2015  
Favaretto & Partners Design



**CHOPPY**  
2015  
Favaretto & Partners Design



**AVENICA**  
2016  
Studio Eurolinea Design

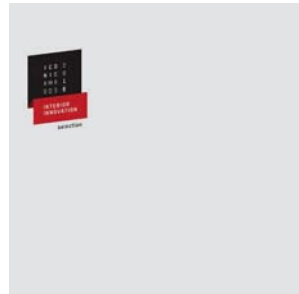

**PLACE**  
2016  
Favaretto & Partners Design



**DIAMANTE**  
2016  
Studio Eurolinea Design



**ELODIE**  
2016  
Marc Sadler Design



**CLIPPERTON**  
2017  
Marc Sadler Design



AWARDS



**ABUELA**  
2018  
Favaretto & Partners Design



**SPYKER**  
2018  
Studio Eurolinea Design



**JUBEL**  
2019  
Forsix Design



**FULLER**  
2019  
Marc Sadler Design

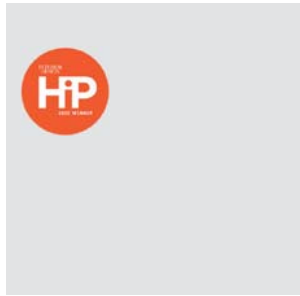

**CUCARACHA**  
2019  
Favaretto & Partners Design



**SUNLOUNGER DOGE**  
2019  
Forsix Design



**NUTA**  
2019  
Favaretto & Partners Design



**AMITHA**  
2021  
Forsix Design



**ARTESIA**  
2021  
Forsix Design



# **TABLES** **Collection**

# Agile

Studio Eurolinea Design

The multifunctional Agile Table Collection reveals essential aesthetics.

Available with rectangular solid laminate tops, the Agile Collection utilizes techno-polymer legs in different colors, supported by a steel frame.

Agile è una collezione di tavoli multifunzionale dall'estetica ricercata ed essenziale.

Realizzato con piani rettangolari in laminato, Agile utilizza gambe in tecnopolimero in diverse colorazioni, supportate da una cornice in acciaio.



Technopolymer Frame Color / Colore Struttura Tecnopolimero

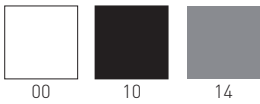

Laminated Top Color / Colore Piano Laminato



Special Finishes / Finiture Speciali

**Laminated:** Special Laminated Surfaces Wood Effect 25 (p. 383) available on demand  
 Special Laminated Surfaces Wood Effect 25 (p. 383) disponibile su richiesta  
 Special Laminated Surfaces Fenix 25 (p. 384) available on demand  
 Special Laminated Surfaces Fenix 25 (p. 384) disponibile su richiesta

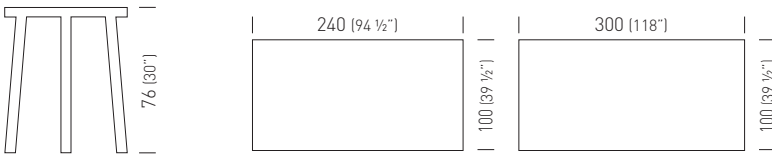

100x240laminated	TAGIL250. __- __/6H75		0.70m <sup>3</sup> / 50kg / 1pcs	€	<b>1970,00</b>
100x300laminated	TAGIL254. __- __/6H75		0.90m <sup>3</sup> / 60kg / 1pcs	€	<b>2438,00</b>

# Aprio

Forsix Design



Frame Color / Colore Struttura



00



10

Compactop Color / Colore Piano Compactop



5547



6076

Aprio is an extendable rectangular garden table, with an epoxy powder coated aluminum frame and compact laminate top. Thanks to the construction materials and the telescopic extending frame, integrated with the legs, the table lends itself perfectly to both indoor and outdoor use. The patented extension system allows the structure to slide, keeping the legs always at the ends of the table. A quick coupling system allows easy extension by inserting one or two of the leaves that are hidden within the frame itself.

Aprio è un tavolo da giardino rettangolare allungabile, con struttura in alluminio verniciato a polveri epossidiche e piano in Compactop. Grazie ai materiali di costruzione e alla struttura telescopica di allungo, solidale con la gamba, il tavolo si presta perfettamente all'utilizzo sia indoor che outdoor. Il sistema brevettato di allungo consente lo scorrimento della struttura, mantenendo le gambe sempre alle estremità del tavolo. E' possibile scegliere di allungare il tavolo aggiungendo con facilità una o due prolunghe, completamente nascoste all'interno della struttura, grazie ad un sistema di aggancio rapido.

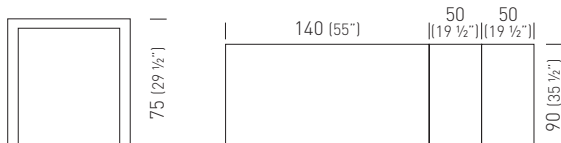

140+50+50x90

TAPRC417. \_\_-\_\_ / H75



0.90m<sup>3</sup> / 48kg / 1pcs

€ **3488,00**

# Arket

Studio Eurolinea Design

The new Arket table collection is made using basic geometrics - radii and linear sections intersect to achieve distinctly intuitive shapes. The aluminum bases have three or four spokes with adjustable feet, and the stems come in sections with three or four surfaces.

The table tops are made of steel: the tables are thus painted in a solid color and easily customizable and adaptable to the most prestigious of installations.

La nuova collezione di tavoli Arket è realizzata utilizzando le geometrie più elementari, raggi e sezioni lineari si intersecano per ricavare forme essenziali ed intuitive.

I basamenti, a tre o quattro razze, con piedini regolabili, e gli steli, a sezioni con tre o quattro superfici, sono realizzati in alluminio. I piani sono realizzati in acciaio: i tavoli sono così verniciati in tinta unita e facilmente personalizzabili ed adattabili alle più prestigiose installazioni.



Colors / Colori

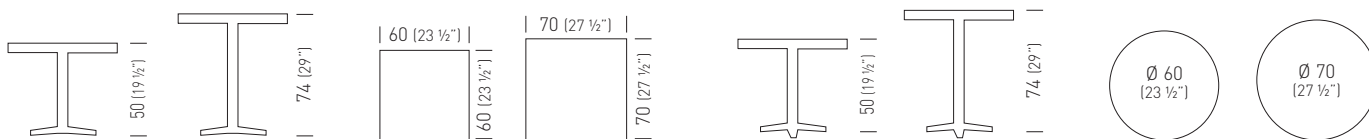
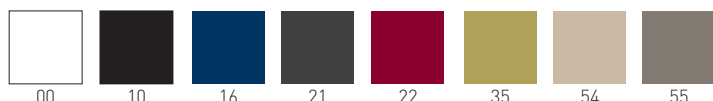

diam.60	TAK3I030.____/H50		0.075m <sup>3</sup> / 10kg / 1pcs	€	<b>357,00</b>
diam.70	TAK3I032.____/H50		0.085m <sup>3</sup> / 10.5kg / 1pcs	€	<b>375,00</b>
60x60	TAK4I031.____/H50		0.075m <sup>3</sup> / 12kg / 1pcs	€	<b>386,00</b>
70x70	TAK4I033.____/H50		0.085m <sup>3</sup> / 13.5kg / 1pcs	€	<b>405,00</b>

diam.60	TAK3I030.____/H74		0.075m <sup>3</sup> / 10.5kg / 1pcs	€	<b>369,00</b>
diam.70	TAK3I032.____/H74		0.085m <sup>3</sup> / 11kg / 1pcs	€	<b>388,00</b>
60x60	TAK4I031.____/H74		0.075m <sup>3</sup> / 12.5kg / 1pcs	€	<b>395,00</b>
70x70	TAK4I033.____/H74		0.085m <sup>3</sup> / 14kg / 1pcs	€	<b>414,00</b>

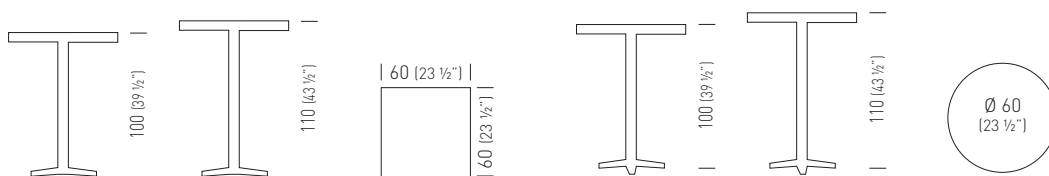

diam.60	TAK3I030.____/H100		0.105m <sup>3</sup> / 11kg / 1pcs	€	<b>409,00</b>
60x60	TAK4I031.____/H100		0.105m <sup>3</sup> / 13kg / 1pcs	€	<b>440,00</b>

diam.60	TAK3I030.____/H110		0.105m <sup>3</sup> / 11kg / 1pcs	€	<b>412,00</b>
60x60	TAK4I031.____/H110		0.105m <sup>3</sup> / 13kg / 1pcs	€	<b>445,00</b>

# Arket Porcelain

Forsix Design



The Porcelain stoneware tops stand out for their excellent technical performance, ideal for the most delicate uses where maximum hygiene and resistance must be guaranteed. Porcelain tops are compatible with foodstuffs, resistant to fungi and molds, suitable for both indoor and outdoor use, resistant to frost, heat and high temperatures, they can be cleaned very easily while maintaining the characteristics of the surface.

I piani in Gres Porcellanato si distinguono per le eccellenti performance tecniche, ideali negli impieghi più delicati nei quali è necessario garantire la massima igiene e resistenza. I piani Porcelain sono compatibili con le sostanze alimentari, resistenti a funghi e muffe, idonei ad un utilizzo sia interno che esterno, resistenti al gelo, al calore e alle alte temperature, si possono pulire con estrema facilità mantenendo inalterate le caratteristiche della superficie.

Frame Color / Colore Struttura

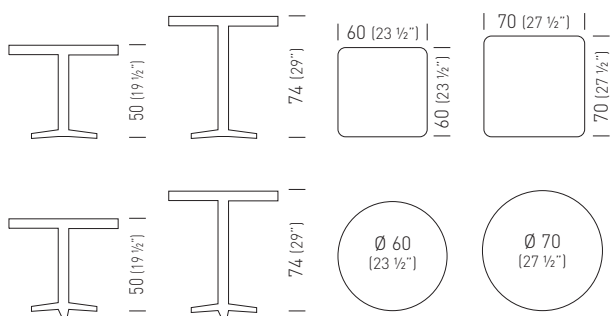
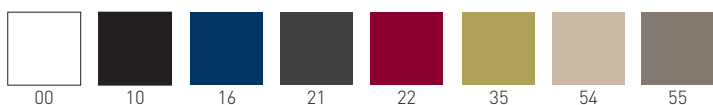

diam.60	TAK3P134. _ _ _ /H50		0.57m <sup>3</sup> / 19.5kg / 1pc	€	<b>784,00</b>
diam.70	TAK3P136. _ _ _ /H50		0.57m <sup>3</sup> / 22.5kg / 1pc	€	<b>921,00</b>
60x60	TAK4P135. _ _ _ /H50		0.57m <sup>3</sup> / 22.5kg / 1pc	€	<b>696,00</b>
70x70	TAK4P137. _ _ _ /H50		0.57m <sup>3</sup> / 25.5kg / 1pc	€	<b>938,00</b>

diam.60	TAK3P134. _ _ _ /H74		0.57m <sup>3</sup> / 20kg / 1pc	€	<b>784,00</b>
diam.70	TAK3P136. _ _ _ /H74		0.57m <sup>3</sup> / 23kg / 1pc	€	<b>921,00</b>
60x60	TAK4P135. _ _ _ /H74		0.57m <sup>3</sup> / 23kg / 1pc	€	<b>696,00</b>
70x70	TAK4P137. _ _ _ /H74		0.57m <sup>3</sup> / 26kg / 1pc	€	<b>938,00</b>

Min. order 10pcs  
each code  
Ordine min 10pz  
per codice

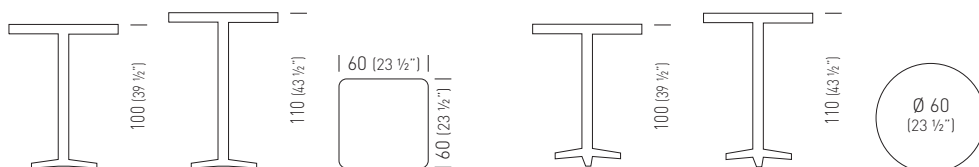

diam.60	TAK3P134. _ _ _ /H100		0.60m <sup>3</sup> / 20.1kg / 1pcs	€	<b>784,00</b>
60x60	TAK4P135. _ _ _ /H100		0.60m <sup>3</sup> / 23.1kg / 1pcs	€	<b>696,00</b>

diam.60	TAK3P134. _ _ _ /H110		0.60m <sup>3</sup> / 20.2kg / 1pcs	€	<b>784,00</b>
60x60	TAK4P135. _ _ _ /H110		0.60m <sup>3</sup> / 23.2kg / 1pcs	€	<b>696,00</b>

Min. order 10pcs  
each code  
Ordine min 10pz  
per codice



# Arket Plus

Forsix Design

Arket Plus Collection is made using basic geometrics, achieving distinctly intuitive shapes. The table tops are made of steel, the three spokes bases are made of co-injected metal and technopolymer. Stem and cross are made in aluminum, and provided with flip-top joint. The shape of the base and the flip-top mechanism allow the table to easily fold and stack, space-saving.

La Collezione di tavoli Arket Plus è realizzata utilizzando le geometrie più elementari, ottenendo così forme essenziali ed intuitive. I piani del tavolo sono realizzati in acciaio, la base a tre razze è costituita da una struttura in metallo co-iniettata con tecnopolimero. Colonna e crociera sono realizzate in alluminio, dotate di giunto per la rotazione del piano. La forma della base e la meccanica che permette la rotazione del piano rendono il tavolo facilmente accatastabile in spazi ridotti.



Colors / Colori

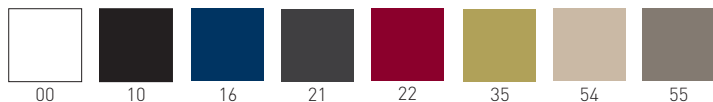

diam.60	TAKPI030._._/H75		0.133m³ / 11.5kg / 1pcs	€	<b>372,00</b>
60x60	TAKPI031._._/H75		0.133m³ / 13.1kg / 1pcs	€	<b>398,00</b>

# Azione Adjustable Desk

Forsix Design



"Azione", Sit-Stand desk table, height adjustable, equipped with bluetooth controller and anti-collision technology.

"Azione", tavolo scrivania Sit-Stand, regolabile elettricamente in altezza, dotato di controller bluetooth e tecnologia anticollisione.

Frame Color / Colore Struttura

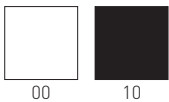

Laminated Top Color / Colore Piano Laminato

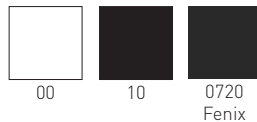

EN60335-1

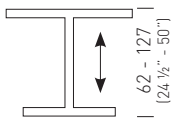

	140 (55")	160 (63")	180 (71")	
		80 (31 1/2")	80 (31 1/2")	80 (31 1/2")
	140 (55")	160 (63")	180 (71")	
	90 (35 1/2")	90 (35 1/2")	90 (35 1/2")	90 (35 1/2")

80x140laminated	TAZNL450._____/H62R	0.67m³ / 26kg / 1pcs	€ <b>1776,00</b>
80x140lam.fenix	TAZNL450.0720-_/H62R	0.67m³ / 26kg / 1pcs	€ <b>2125,00</b>
80x160laminated	TAZNL451._____/H62R	0.70m³ / 28kg / 1pcs	€ <b>1826,00</b>
80x160lam.fenix	TAZNL451.0720-_/H62R	0.70m³ / 28kg / 1pcs	€ <b>2223,00</b>
80x180laminated	TAZNL452._____/H62R	0.75m³ / 30kg / 1pcs	€ <b>1876,00</b>
80x180lam.fenix	TAZNL452.0720-_/H62R	0.75m³ / 30kg / 1pcs	€ <b>2322,00</b>
90x140laminated	TAZNL453._____/H62R	0.70m³ / 28kg / 1pcs	€ <b>1826,00</b>
90x140lam.fenix	TAZNL453.0720-_/H62R	0.70m³ / 28kg / 1pcs	€ <b>2223,00</b>
90x160laminated	TAZNL454._____/H62R	0.75m³ / 30kg / 1pcs	€ <b>1876,00</b>
90x160lam.fenix	TAZNL454.0720-_/H62R	0.75m³ / 30kg / 1pcs	€ <b>2322,00</b>
90x180laminated	TAZNL455._____/H62R	0.80m³ / 33kg / 1pcs	€ <b>1925,00</b>
90x180lam.fenix	TAZNL455.0720-_/H62R	0.80m³ / 33kg / 1pcs	€ <b>2420,00</b>

# Banket

Studio Eurolinea Design

High table, Compactop or Laminated table top, painted metal frame.

Tavolo alto con struttura in metallo verniciato, piano in Compactop o Laminato.



Only for Compactop  
Solo per Compactop



Frame Color / Colore Struttura

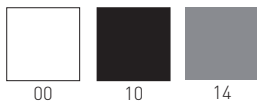

Compactop Color / Colore Piano Compactop

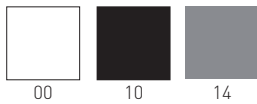

Laminated Top Color / Colore Piano Laminato



Special Finishes / Finiture Speciali

**Compactop:** Special Compactop Surfaces Fullcolor (p. 377) available on demand (min. 5pcs each code).  
Special Compactop Surfaces Fullcolor (p. 377) disponibile su richiesta (min. 5pcs per codice).  
Special Compactop Surfaces 10 (p. 378) available on demand (min. 20pcs each code).

**Laminated:** Special Laminated Surfaces Wood Effect 25 (p. 383) available on demand (min. 20pcs each code).  
Special Laminated Surfaces Wood Effect 25 (p. 383) disponibile su richiesta (min. 20pcs per codice).  
Special Laminated Surfaces Fenix 25 (p. 384) available on demand (min. 20pcs each code).  
Special Laminated Surfaces Fenix 25 (p. 384) disponibile su richiesta (min. 20pcs per codice).

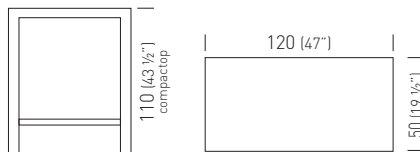

120x50compactop  
120x50laminated

TBNKC800. \_\_-\_\_ /H110  
TBNKL804. \_\_-\_\_ /H110



0.47m<sup>3</sup> / 18kg / 1pcs



€ 550,00  
€ 454,00

# Bristol

Forsix Design



Only Steel and Compactop  
Solo piani Acciaio e Compactop

Frame Color / Colore Struttura

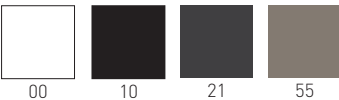

Compactop Color / Colore Piano Compactop

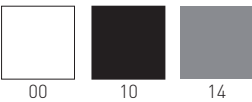

Laminated Top Color / Colore Piano Laminato



Steel Top Color / Colore Piano Acciaio

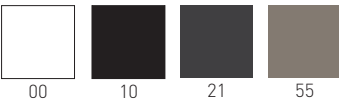

Special Finishes / Finiture Speciali

**Compactop:** Special Compactop Surfaces Fullcolor (p. 377) available on demand (min. 5pcs each code).  
Special Compactop Surfaces Fullcolor (p. 377) disponibile su richiesta (min. 5pcs per codice).  
Special Compactop Surfaces Fenix (p. 380) available on demand (min. 20pcs each code).  
Special Compactop Surfaces Fenix (p. 380) disponibile su richiesta (min. 20pcs per codice).  
Special Compactop Surfaces 10 (p. 378) available on demand (min. 20pcs each code).  
Special Compactop Surfaces 10 (p. 378) disponibile su richiesta (min. 20pcs per codice).

**Laminated:** Special Laminated Surfaces Wood Effect (p. 383) available on demand (min. 20pcs each code).  
Special Laminated Surfaces Wood Effect (p. 383) disponibile su richiesta (min. 20pcs per codice).  
Special Laminated Surfaces Fenix (p. 384) available on demand (min. 20pcs each code).  
Special Laminated Surfaces Fenix (p. 384) disponibile su richiesta (min. 20pcs per codice).

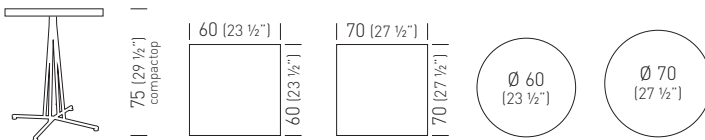

60x60 laminated	TBRSL383. __-__ /H75		0.28m <sup>3</sup> / 15kg / 1pc	€	<b>319,00</b>
70x70 laminated	TBRSL385. __-__ /H75		0.30m <sup>3</sup> / 18kg / 1pc	€	<b>329,00</b>
diam.60 laminated	TBRSL382. __-__ /H75		0.28m <sup>3</sup> / 14kg / 1pc	€	<b>329,00</b>
diam.70 laminated	TBRSL384. __-__ /H75		0.30m <sup>3</sup> / 15kg / 1pc	€	<b>364,00</b>
60x60 compactop	TBRSC363. __-__ /H75		0.28m <sup>3</sup> / 14.5kg / 1pc	€	<b>353,00</b>
70x70 compactop	TBRSC369. __-__ /H75		0.30m <sup>3</sup> / 18kg / 1pc	€	<b>378,00</b>
diam.60 compactop	TBRSC360. __-__ /H75		0.28m <sup>3</sup> / 14kg / 1pc	€	<b>394,00</b>
diam.70 compactop	TBRSC366. __-__ /H75		0.30m <sup>3</sup> / 15kg / 1pc	€	<b>432,00</b>
60x60 steel	TBRSL377. __-__ /H75		0.28m <sup>3</sup> / 16kg / 1pc	€	<b>388,00</b>
70x70 steel	TBRSL379. __-__ /H75		0.30m <sup>3</sup> / 21kg / 1pc	€	<b>406,00</b>
diam.60 steel	TBRSL376. __-__ /H75		0.28m <sup>3</sup> / 14kg / 1pc	€	<b>386,00</b>
diam.70 steel	TBRSL378. __-__ /H75		0.30m <sup>3</sup> / 18kg / 1pc	€	<b>405,00</b>

# Charme

Studio Eurolinea Design

Elegance and essential shapes find a new expression in the Charme table, a proposal designed for workspace and hospitality environments, which is characterized by the particular design of the metal legs.

The regular shapes harmonize each other, creating a product also suitable for conviviality, thanks to the top in "Iron" composite material which highlights great stability and resistance.

Eleganza ed essenzialità trovano una nuova espressione nel tavolo Charme, una proposta ideata per lo spazio di lavoro e dell'ospitalità, che si caratterizza per il particolare design delle gambe in metallo.

Le forme regolari si armonizzano tra loro, dando vita a un progetto improntato anche alla convivialità, grazie al piano in materiale composito "Iron" dalla grande stabilità e resistenza.



Colors / Colori



00



10

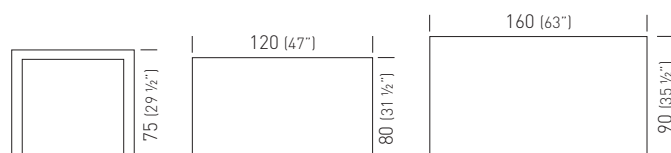

80x120  
90x160

TCHAI400.\_/H75  
TCHAI402.\_/H75



0.48m<sup>3</sup> / 20kg / 1pcs  
0.72m<sup>3</sup> / 22kg / 1pcs



**1155,00**  
**1380,00**



# Claro

Studio Eurolinea Design



Table with co-injected metal frame with techno polymer, Compactop or laminated top. Suitable for outdoor purpose with Compactop.

Tavolo con struttura in metallo sovrastampato con tecnopolimero, piano in Compactop o laminato.

Con piano Compactop, adatto anche all'uso esterno.



Only for Compactop  
Solo per Compactop



Frame Color / Colore Struttura

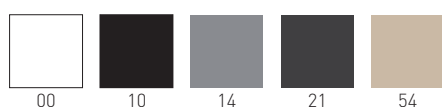

Compactop Color / Colore Piano Compactop

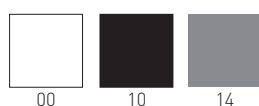

Laminated Top Color / Colore Piano Laminato



Special Finishes / Finiture Speciali

**Compactop** Special Compactop Surfaces 10 (p. 378) available on demand (min. 20pcs each code).  
Special Compactop Surfaces 10 (p. 378) disponibile su richiesta (min. 20pcs per codice).  
**Laminated:** Special Laminated Surfaces Wood Effect 25 (p. 383) available on demand (min. 20pcs each code)  
Special Laminated Surfaces Wood Effect 25 (p. 383) disponibile su richiesta (min. 20pcs per codice)  
Special Laminated Surfaces Fenix 25 (p. 384) available on demand (min. 20pcs each code)  
Special Laminated Surfaces Fenix 25 (p. 384) disponibile su richiesta (min. 20pcs per codice)

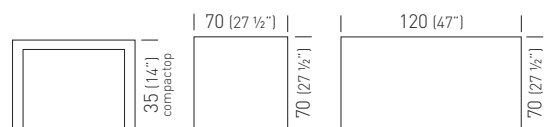

70x70compactop	TCLAC570. __-__ /H35		0.24m <sup>3</sup> / 20kg / 1pcs	€	<b>364,00</b>
70x70laminated	TCLAL580. __-__ /H35		0.24m <sup>3</sup> / 20kg / 1pcs	€	<b>335,00</b>
70x70fullcolor (min 5pcs)	TCLAC571.00-__ /H35		0.24m <sup>3</sup> / 20kg / 1pcs	€	<b>436,00</b>
70x120compactop	TCLAC572. __-__ /H35		0.36m <sup>3</sup> / 25kg / 1pcs	€	<b>547,00</b>
70x120laminated	TCLAL582. __-__ /H35		0.36m <sup>3</sup> / 25kg / 1pcs	€	<b>502,00</b>
70x120fullcolor (min 5pcs)	TCLAC573.00-__ /H35		0.36m <sup>3</sup> / 25kg / 1pcs	€	<b>654,00</b>

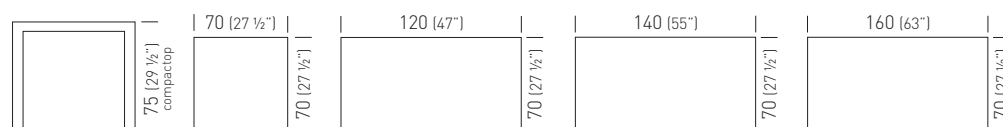

70x70compactop	TCLAC570. __-__ /H75		0.24m <sup>3</sup> / 22kg / 1pcs	€	<b>364,00</b>
70x70laminated	TCLAL580. __-__ /H75		0.24m <sup>3</sup> / 22kg / 1pcs	€	<b>335,00</b>
70x70fullcolor (min 5pcs)	TCLAC571.00-__ /H75		0.24m <sup>3</sup> / 22kg / 1pcs	€	<b>436,00</b>
70x120compactop	TCLAC572. __-__ /H75		0.36m <sup>3</sup> / 27kg / 1pcs	€	<b>547,00</b>
70x120laminated	TCLAL582. __-__ /H75		0.36m <sup>3</sup> / 27kg / 1pcs	€	<b>502,00</b>
70x120fullcolor (min 5pcs)	TCLAC573.00-__ /H75		0.36m <sup>3</sup> / 27kg / 1pcs	€	<b>654,00</b>
70x140compactop	TCLAC574. __-__ /H75		0.41m <sup>3</sup> / 31kg / 1pcs	€	<b>729,00</b>
70x140laminated	TCLAL584. __-__ /H75		0.41m <sup>3</sup> / 31kg / 1pcs	€	<b>670,00</b>
70x140fullcolor (min 5pcs)	TCLAC575.00-__ /H75		0.41m <sup>3</sup> / 31kg / 1pcs	€	<b>874,00</b>
70x160compactop	TCLAC576. __-__ /H75		0.46m <sup>3</sup> / 35kg / 1pcs	€	<b>910,00</b>
70x160laminated	TCLAL586. __-__ /H75		0.46m <sup>3</sup> / 35kg / 1pcs	€	<b>839,00</b>
70x160fullcolor (min 5pcs)	TCLAC577.00-__ /H75		0.46m <sup>3</sup> / 35kg / 1pcs	€	<b>1091,00</b>

# Claro

Studio Eurolinea Design



Only for Compactop  
Solo per Compactop



## Frame Color / Colore Struttura

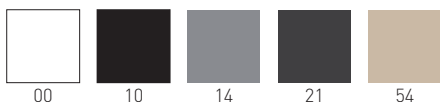

## Compactop Color / Colore Piano Compactop

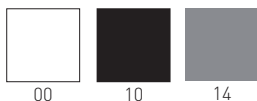

## Laminated Top Color / Colore Piano Laminato



## Special Finishes / Finiture Speciali

**Compactop** Special Compactop Surfaces 10 (p. 378) available on demand (min. 20pcs each code).  
Special Compactop Surfaces 10 (p. 378) disponibile su richiesta (min. 20pcs per codice).  
**Laminated:** Special Laminated Surfaces Wood Effect 25 (p. 383) available on demand (min. 20pcs each code).  
Special Laminated Surfaces Wood Effect 25 (p. 383) disponibile su richiesta (min. 20pcs per codice).  
Special Laminated Surfaces Fenix 25 (p. 384) available on demand (min. 20pcs each code).  
Special Laminated Surfaces Fenix 25 (p. 384) disponibile su richiesta (min. 20pcs per codice).

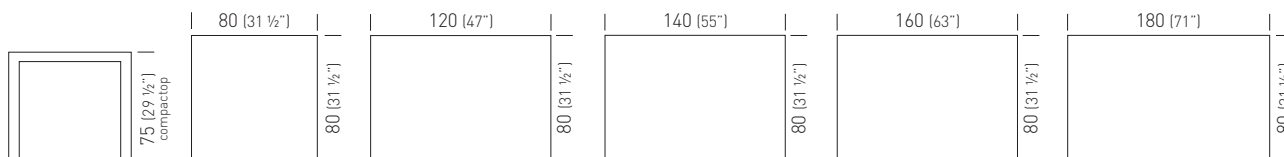

80x80compactop	TCLAC590.___/H75		0.24m <sup>3</sup> / 31kg / 1pcs	€	<b>425,00</b>
80x80laminated	TCLAL600.___/H75		0.24m <sup>3</sup> / 31kg / 1pcs	€	<b>394,00</b>
80x80fullcolor (min 5pcs)	TCLAC591.00-_/H75		0.24m <sup>3</sup> / 31kg / 1pcs	€	<b>508,00</b>
80x120compactop	TCLAC592.___/H75		0.36m <sup>3</sup> / 38kg / 1pcs	€	<b>606,00</b>
80x120laminated	TCLAL602.___/H75		0.36m <sup>3</sup> / 38kg / 1pcs	€	<b>561,00</b>
80x120fullcolor (min 5pcs)	TCLAC593.00-_/H75		0.36m <sup>3</sup> / 38kg / 1pcs	€	<b>725,00</b>
80x140compactop	TCLAC594.___/H75		0.41m <sup>3</sup> / 40kg / 1pcs	€	<b>787,00</b>
80x140laminated	TCLAL604.___/H75		0.41m <sup>3</sup> / 40kg / 1pcs	€	<b>729,00</b>
80x140fullcolor (min 5pcs)	TCLAC595.00-_/H75		0.41m <sup>3</sup> / 40kg / 1pcs	€	<b>946,00</b>
80x160compactop	TCLAC596.___/H75		0.46m <sup>3</sup> / 42kg / 1pcs	€	<b>969,00</b>
80x160laminated	TCLAL606.___/H75		0.46m <sup>3</sup> / 42kg / 1pcs	€	<b>897,00</b>
80x160fullcolor (min 5pcs)	TCLAC597.00-_/H75		0.46m <sup>3</sup> / 42kg / 1pcs	€	<b>1163,00</b>
80x180compactop	TCLAC598.___/H75		0.60m <sup>3</sup> / 44kg / 1pcs	€	<b>1043,00</b>
80x180laminated	TCLAL608.___/H75		0.60m <sup>3</sup> / 44kg / 1pcs	€	<b>925,00</b>
80x180fullcolor (min 5pcs)	TCLAC599.00-_/H75		0.60m <sup>3</sup> / 44kg / 1pcs	€	<b>1254,00</b>



Only for Compactop  
Solo per Compactop

Frame Color / Colore Struttura

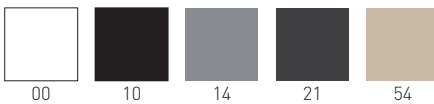

Compactop Color / Colore Piano Compactop

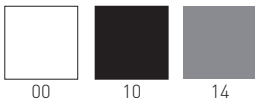

Laminated Top Color / Colore Piano Laminato



Special Finishes / Finiture Speciali

**Compactop** Special Compactop Surfaces 10 (p. 378) available on demand (min. 20pcs each code).  
Special Compactop Surfaces 10 (p. 378) disponibile su richiesta (min. 20pcs per codice).  
**Laminated:** Special Laminated Surfaces Wood Effect 25 (p. 383) available on demand (min. 20pcs each code).  
Special Laminated Surfaces Wood Effect 25 (p. 383) disponibile su richiesta (min. 20pcs per codice).  
Special Laminated Surfaces Fenix 25 (p. 384) available on demand (min. 20pcs each code).  
Special Laminated Surfaces Fenix 25 (p. 384) disponibile su richiesta (min. 20pcs per codice).

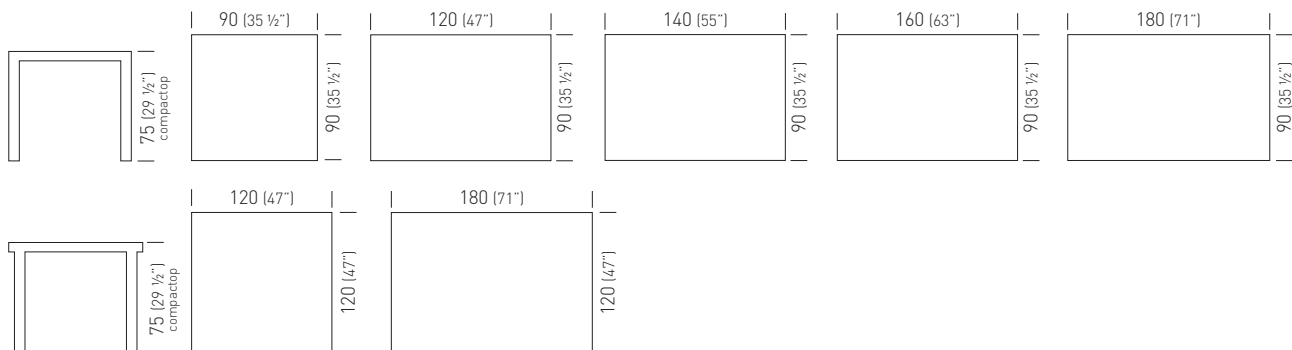

90x90compactop	TCLAC610.___/H75		0.54m <sup>3</sup> / 33kg / 1pcs	€	<b>493,00</b>
90x90laminated	TCLAL620.___/H75		0.54m <sup>3</sup> / 33kg / 1pcs	€	<b>463,00</b>
90x90fullcolor (min 5pcs)	TCLAC611.00-_/H75		0.54m <sup>3</sup> / 33kg / 1pcs	€	<b>591,00</b>
90x120compactop	TCLAC612.___/H75		0.54m <sup>3</sup> / 36kg / 1pcs	€	<b>684,00</b>
90x120laminated	TCLAL622.___/H75		0.54m <sup>3</sup> / 36kg / 1pcs	€	<b>642,00</b>
90x120fullcolor (min 5pcs)	TCLAC613.00-_/H75		0.54m <sup>3</sup> / 36kg / 1pcs	€	<b>820,00</b>
90x140compactop	TCLAC614.___/H75		0.65m <sup>3</sup> / 39kg / 1pcs	€	<b>866,00</b>
90x140laminated	TCLAL624.___/H75		0.65m <sup>3</sup> / 39kg / 1pcs	€	<b>808,00</b>
90x140fullcolor (min 5pcs)	TCLAC615.00-_/H75		0.65m <sup>3</sup> / 39kg / 1pcs	€	<b>1040,00</b>
90x160compactop	TCLAC616.___/H75		0.75m <sup>3</sup> / 41kg / 1pcs	€	<b>1048,00</b>
90x160laminated	TCLAL626.___/H75		0.75m <sup>3</sup> / 41kg / 1pcs	€	<b>977,00</b>
90x160fullcolor (min 5pcs)	TCLAC617.00-_/H75		0.75m <sup>3</sup> / 41kg / 1pcs	€	<b>1257,00</b>
90x180compactop	TCLAC618.___/H75		0.80m <sup>3</sup> / 43kg / 1pcs	€	<b>1142,00</b>
90x180laminated	TCLAL628.___/H75		0.80m <sup>3</sup> / 43kg / 1pcs	€	<b>1023,00</b>
90x180fullcolor (min 5pcs)	TCLAC619.00-_/H75		0.80m <sup>3</sup> / 43kg / 1pcs	€	<b>1372,00</b>
120x120laminated	TCLAL670.___/H75		0.70m <sup>3</sup> / 38kg / 1pcs	€	<b>780,00</b>
120x180laminated	TCLAL672.___/H75		1.00m <sup>3</sup> / 45kg / 1pcs	€	<b>1173,00</b>



# Claro Slim

Studio Eurolinea Design

Table with co-injected metal frame with techno polymer, Compactop or laminated top. Suitable for outdoor purpose with Compactop.

Tavolo con struttura in metallo sovrastampato con tecnopolimero, piano in Compactop o laminato. Con piano Compactop, adatto anche all'uso esterno.



Only for Compactop  
Solo per Compactop



Frame Color / Colore Struttura

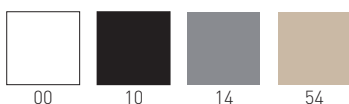

Compactop Color / Colore Piano Compactop

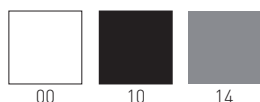

Laminated Top Color / Colore Piano Laminato



Special Finishes / Finiture Speciali

**Compactop:** Special Compactop Surfaces 10 (p. 378) available on demand (min. 20pcs each code)  
Special Compactop Surfaces 10 (p. 378) disponibile su richiesta (min. 20pcs per codice).  
**Laminated:** Special Laminated Surfaces Wood Effect 25 (p. 383) available on demand (min. 20pcs each code)  
Special Laminated Surfaces Wood Effect 25 (p. 383) disponibile su richiesta (min. 20pcs per codice)  
Special Laminated Surfaces Fenix 25 (p. 384) available on demand (min. 20pcs each code)  
Special Laminated Surfaces Fenix 25 (p. 384) disponibile su richiesta (min. 20pcs per codice)

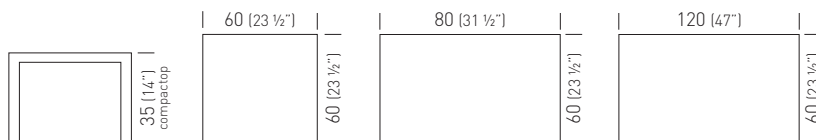

60x60compactop	TCLAC640.___/H35		0.15m <sup>3</sup> / 17kg / 1pcs	€	<b>338,00</b>
60x60laminated	TCLAL650.___/H35		0.15m <sup>3</sup> / 17kg / 1pcs	€	<b>319,00</b>
60x60fullcolor (min 5pcs)	TCLAC641.00-_/H35		0.15m <sup>3</sup> / 17kg / 1pcs	€	<b>411,00</b>
60x80compactop	TCLAC642.___/H35		0.18m <sup>3</sup> / 19kg / 1pcs	€	<b>358,00</b>
60x80laminated	TCLAL652.___/H35		0.18m <sup>3</sup> / 19kg / 1pcs	€	<b>338,00</b>
60x80fullcolor (min 5pcs)	TCLAC643.00-_/H35		0.18m <sup>3</sup> / 19kg / 1pcs	€	<b>432,00</b>
60x120compactop	TCLAC644.___/H35		0.36m <sup>3</sup> / 23kg / 1pcs	€	<b>496,00</b>
60x120laminated	TCLAL654.___/H35		0.36m <sup>3</sup> / 23kg / 1pcs	€	<b>467,00</b>
60x120fullcolor (min 5pcs)	TCLAC645.00-_/H35		0.36m <sup>3</sup> / 23kg / 1pcs	€	<b>597,00</b>

# Claro Slim

Studio Eurolinea Design



Only for Compactop  
Solo per Compactop

Frame Color / Colore Struttura

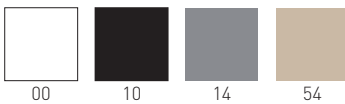

Compactop Color / Colore Piano Compactop

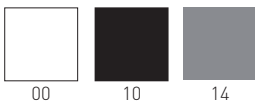

Laminated Top Color / Colore Piano Laminato



Special Finishes / Finiture Speciali

**Compactop:** Special Compactop Surfaces 10 (p. 378) available on demand (min. 20pcs each code)  
Special Compactop Surfaces 10 (p. 378) disponibile su richiesta (min. 20pcs per codice).  
**Laminated:** Special Laminated Surfaces Wood Effect 25 (p. 383) available on demand (min. 20pcs each code)  
Special Laminated Surfaces Wood Effect 25 (p. 383) disponibile su richiesta (min. 20pcs per codice)  
Special Laminated Surfaces Fenix 25 (p. 384) available on demand (min. 20pcs each code)  
Special Laminated Surfaces Fenix 25 (p. 384) disponibile su richiesta (min. 20pcs per codice)

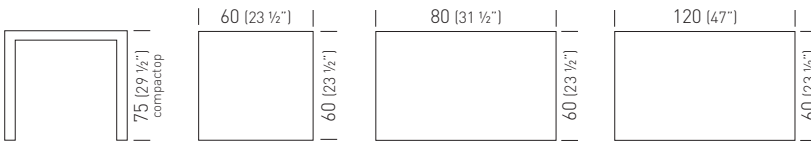

60x60compactop	TCLAC640.__-_/H75		0.15m <sup>3</sup> / 19kg / 1pcs	€	<b>352,00</b>
60x60laminated	TCLAL650.__-_/H75		0.15m <sup>3</sup> / 19kg / 1pcs	€	<b>332,00</b>
60x60fullcolor (min 5pcs)	TCLAC641.00-_/H75		0.15m <sup>3</sup> / 19kg / 1pcs	€	<b>422,00</b>
60x80compactop	TCLAC642.__-_/H75		0.18m <sup>3</sup> / 21kg / 1pcs	€	<b>370,00</b>
60x80laminated	TCLAL652.__-_/H75		0.18m <sup>3</sup> / 21kg / 1pcs	€	<b>352,00</b>
60x80fullcolor (min 5pcs)	TCLAC643.00-_/H75		0.18m <sup>3</sup> / 21kg / 1pcs	€	<b>446,00</b>
60x120compactop	TCLAC644.__-_/H75		0.36m <sup>3</sup> / 25kg / 1pcs	€	<b>508,00</b>
60x120laminated	TCLAL654.__-_/H75		0.36m <sup>3</sup> / 25kg / 1pcs	€	<b>479,00</b>
60x120fullcolor (min 5pcs)	TCLAC645.00-_/H75		0.36m <sup>3</sup> / 25kg / 1pcs	€	<b>611,00</b>

# Claro Slim

Studio Eurolinea Design

High table, Compactop or Laminated table top, painted metal frame.

Tavolo alto con struttura in metallo verniciato, piano in Compactop o Laminato.



Only for Compactop  
Solo per Compactop



Frame Color / Colore Struttura

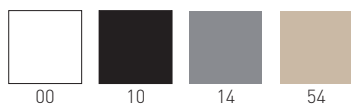

Compactop Color / Colore Piano Compactop



Laminated Top Color / Colore Piano Laminato



Special Finishes / Finiture Speciali

**Compactop:** Special Compactop Surfaces 10 (p.325) available on demand (min. 20pcs each code)

Special Compactop Surfaces 10 (p. 325) disponibile su richiesta (min. 20pcs per codice).

**Laminated:** Special Laminated Surfaces Wood Effect 25 (p. 383) available on demand (min. 20pcs each code)

Special Laminated Surfaces Wood Effect 25 (p. 383) disponibile su richiesta (min. 20pcs per codice)

Special Laminated Surfaces Fenix 25 (p. 384) available on demand (min. 20pcs each code)

Special Laminated Surfaces Fenix 25 (p. 384) disponibile su richiesta (min. 20pcs per codice)

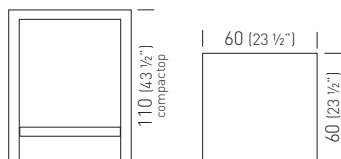

60x60compactop

TCLAC640.\_\_-\_/H110  0.20m<sup>3</sup> / 21kg / 1pcs

€ **411,00**

60x60laminated

TCLAL650.\_\_-\_/H110  0.20m<sup>3</sup> / 21kg / 1pcs

€ **391,00**

60x60fullcolor (min 5pcs)

TCLAC641.00-\_/H110  0.20m<sup>3</sup> / 21kg / 1pcs

€ **481,00**

# Flipaway

Forsix Design

"Flipaway" table for conference environment, provided with laminated table top and breaking castors, ensures complete frontal stackability.  
 "Flipaway": tavolo con piano in laminato adatto ad ambienti conferenza, accatastabile frontalmente e dotato di ruote con freno.



Frame Color / Colore Struttura

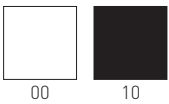

Laminated Top Color / Colore Piano Laminato

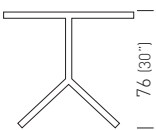
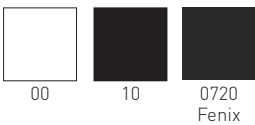

120 (47")	150 (59")	180 (71")
80 (31 1/2")	80 (31 1/2")	80 (31 1/2")
120 (47")	150 (59")	180 (71")
90 (35 1/2")	90 (35 1/2")	90 (35 1/2")

80x120laminated	TFLPL460.___-_/H76	0.6m³ / 27kg / 1pcs	€ <b>657,00</b>
80x120lam.fenix	TFLPL460.0720-_/H76	0.6m³ / 27kg / 1pcs	€ <b>704,00</b>
80x150laminated	TFLPL461.___-_/H76	0.7m³ / 30kg / 1pcs	€ <b>825,00</b>
80x150lam.fenix	TFLPL461.0720-_/H76	0.7m³ / 30kg / 1pcs	€ <b>863,00</b>
80x180laminated	TFLPL462.___-_/H76	0.8m³ / 33kg / 1pcs	€ <b>882,00</b>
80x180lam.fenix	TFLPL462.0720-_/H76	0.8m³ / 33kg / 1pcs	€ <b>938,00</b>
90x120laminated	TFLPL463.___-_/H76	0.6m³ / 30kg / 1pcs	€ <b>694,00</b>
90x120lam.fenix	TFLPL463.0720-_/H76	0.6m³ / 30kg / 1pcs	€ <b>742,00</b>
90x150laminated	TFLPL464.___-_/H76	0.7m³ / 33kg / 1pcs	€ <b>863,00</b>
90x150lam.fenix	TFLPL464.0720-_/H76	0.7m³ / 33kg / 1pcs	€ <b>919,00</b>
90x180laminated	TFLPL465.___-_/H76	0.8m³ / 36kg / 1pcs	€ <b>919,00</b>
90x180lam.fenix	TFLPL465.0720-_/H76	0.8m³ / 36kg / 1pcs	€ <b>975,00</b>

# Format

Studio Eurolinea Design

Table with metal painted frame and Compactop table top.

Suitable for outdoor purpose. Adjustable feet.

Tavolo con struttura in metallo verniciato, piano in Compactop.

Adatto anche all'uso esterno. Piedini regolabili.



Frame Color / Colore Struttura

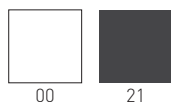

Compactop Color / Colore Piano Compactop



Special Finishes / Finiture Speciali

**Compactop:** Special Compactop Surfaces Fullcolor (p. 377) available on demand (min. 5pcs each code).  
Special Compactop Surfaces Fullcolor (p. 377) disponibile su richiesta (min. 5pcs per codice).  
Special Compactop Surfaces 10 (p. 378) available on demand (min. 20pcs each code).  
Special Compactop Surfaces 10 (p. 378) disponibile su richiesta (min. 20pcs per codice).

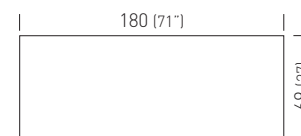
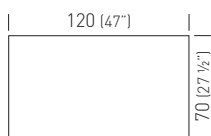
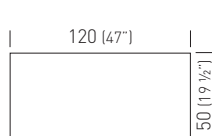
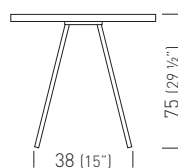

120x50	TFORC840.___/H75	0.47m³ / 23kg / 1pcs	€ <b>611,00</b>
120x70	TFORC842.___/H75	0.48m³ / 24kg / 1pcs	€ <b>622,00</b>
180x50	TFORC844.___/H75	0.80m³ / 25kg / 1pcs	€ <b>629,00</b>
180x69	TFORC846.___/H75	0.80m³ / 26kg / 1pcs	€ <b>662,00</b>

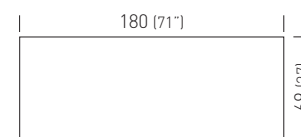
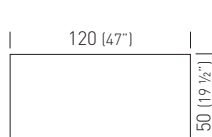
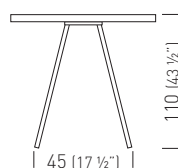

120x50	TFORC840.___/H110	0.47m³ / 25kg / 1pcs	€ <b>629,00</b>
120x70	TFORC842.___/H110	0.48m³ / 26kg / 1pcs	€ <b>643,00</b>
180x50	TFORC844.___/H110	0.80m³ / 27kg / 1pcs	€ <b>651,00</b>
180x69	TFORC846.___/H110	0.80m³ / 28kg / 1pcs	€ <b>684,00</b>

# Glitter

Forsix Design



Only Compactop  
Solo piani Compactop

The Glitter table oozes simplicity and practicality. The sturdy steel structure with its three support points is also available at poseur height and features essential minimalist design, in order to fit in discreetly to any environment. Base are in epoxy powder coated steel with outdoor treatment, table tops are available in Compactop or Laminated.

Il tavolo Glitter esprime semplicità e praticità. La stabile struttura in acciaio a tre punti di appoggio, disponibile anche nell'altezza snack, è caratterizzata da un design essenziale e minimale, per potersi relazionare con discrezione agli ambienti di utilizzo. Le basi sono realizzate in acciaio verniciato a polveri epossidiche con trattamento per esterno, i piani possono essere realizzati in Compactop o Laminato.

## Frame Color / Colore Struttura

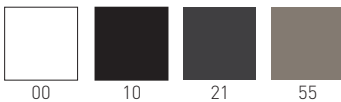

## Compactop Color / Colore Piano Compactop

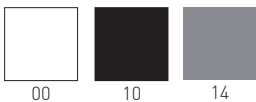

## Laminated Top Color / Colore Piano Laminato



## Special Finishes / Finiture Speciali

**Compactop:** Special Compactop Surfaces Fullcolor (p. 377) available on demand (min. 5pcs each code).  
Special Compactop Surfaces Fullcolor (p. 377) disponibile su richiesta (min. 5pcs per codice).  
Special Compactop Surfaces Fenix (p. 380) available on demand (min. 20pcs each code).  
Special Compactop Surfaces Fenix (p. 380) disponibile su richiesta (min. 20pcs per codice).  
Special Compactop Surfaces 10 (p. 378) available on demand (min. 20pcs each code).  
Special Compactop Surfaces 10 (p. 378) disponibile su richiesta (min. 20pcs per codice).

**Laminated:** Special Laminated Surfaces Wood Effect (p. 383) available on demand (min. 20pcs each code).  
Special laminated Surfaces Wood Effect (p. 383) disponibile su richiesta (min. 20pcs per codice).  
Special Laminated Surfaces Fenix (p. 384) available on demand (min. 20pcs each code).  
Special laminated Surfaces Fenix (p. 384) disponibile su richiesta (min. 20pcs per codice).

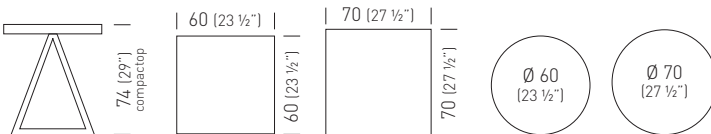

60x60 laminated	TGLTL557._._/H74		0.23m <sup>3</sup> / 12.4kg / 1pc	€	<b>291,00</b>
70x70 laminated	TGLTL559._._/H74		0.25m <sup>3</sup> / 15.4kg / 1pc	€	<b>302,00</b>
diam.60 laminated	TGLTL556._._/H74		0.23m <sup>3</sup> / 11.4kg / 1pc	€	<b>302,00</b>
diam.70 laminated	TGLTL558._._/H74		0.25m <sup>3</sup> / 12.4kg / 1pc	€	<b>338,00</b>
60x60 compactop	TGLTC543._._/H74		0.23m <sup>3</sup> / 11.9kg / 1pc	€	<b>357,00</b>
70x70 compactop	TGLTC549._._/H74		0.25m <sup>3</sup> / 15.4kg / 1pc	€	<b>386,00</b>
diam.60 compactop	TGLTC540._._/H74		0.23m <sup>3</sup> / 11.4kg / 1pc	€	<b>406,00</b>
diam.70 compactop	TGLTC546._._/H74		0.25m <sup>3</sup> / 12.4kg / 1pc	€	<b>451,00</b>

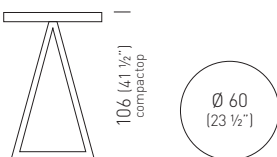

diam.60 laminated	TGLTL556._._/H105		0.25m <sup>3</sup> / 12.05kg / 1pc	€	<b>344,00</b>
diam.60 compactop	TGLTC540._._/H105		0.25m <sup>3</sup> / 12.05kg / 1pc	€	<b>448,00</b>



60x180 laminated	TGLTL561._._/2H105		0.39m <sup>3</sup> / 27.5kg / 1pc	€	<b>789,00</b>
70x180 laminated	TGLTL562._._/2H105		0.39m <sup>3</sup> / 29.9kg / 1pc	€	<b>823,00</b>

# Hug

Studio Eurolinea Design

The Hug collection is characterized by the possibility of combine table tops in Compactop or Steel, which can also be used outdoors, or in Laminated, for the most specific indoor settings. The table is made with a 4-star aluminum base, equipped with adjustable feet, and aluminum column and cross.

La collezione Hug è caratterizzata dalla possibilità di poter abbinare piani tavoli in Compactop e Steel, utilizzabili anche all'esterno, o in Laminato per le più specifiche ambientazioni indoor. Il tavolo è realizzato con basamento 4 razze in alluminio, dotato di piedini regolabili, e da colonna e crociera in alluminio.



Only Steel and Compactop  
Solo piani Acciaio e Compactop



Frame Color / Colore Struttura

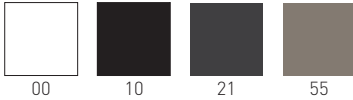

Compactop Color / Colore Piano Compactop

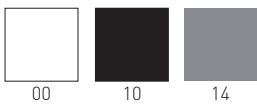

Laminated Top Color / Colore Piano Laminato



Steel Top Color / Colore Piano Acciaio

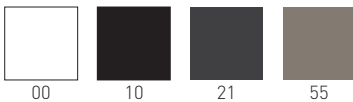

Special Finishes / Finiture Speciali

**Compactop:** Special Compactop Surfaces Fullcolor (p. 377) available on demand (min. 5pcs each code).  
Special Compactop Surfaces Fullcolor (p. 377) disponibile su richiesta (min. 5pcs per codice).  
Special Compactop Surfaces Fenix (p. 380) available on demand (min. 20pcs each code).  
Special Compactop Surfaces Fenix (p. 380) disponibile su richiesta (min. 20pcs per codice).  
Special Compactop Surfaces 10 (p. 378) available on demand (min. 20pcs each code).  
Special Compactop Surfaces 10 (p. 378) disponibile su richiesta (min. 20pcs per codice).

**Laminated:** Special Laminated Surfaces Wood Effect (p. 383) available on demand (min. 20pcs each code).  
Special laminated Surfaces Wood Effect (p. 383) disponibile su richiesta (min. 20pcs per codice).  
Special Laminated Surfaces Fenix (p. 384) available on demand (min. 20pcs each code).  
Special laminated Surfaces Fenix (p. 384) disponibile su richiesta (min. 20pcs per codice).

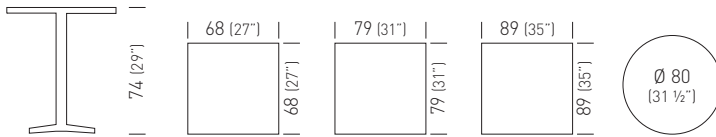

68x68compactop	THUGC200._._/H74		0.17m <sup>3</sup> / 15.1kg / 1pc	€	<b>408,00</b>
79x79compactop	THUGC204._._/H74		0.18m <sup>3</sup> / 15.6kg / 1pc	€	<b>431,00</b>
89x89compactop	THUGC212._._/H74		0.20m <sup>3</sup> / 18.1kg / 1pc	€	<b>505,00</b>
diam.80compactop	THUGC208._._/H74		0.18m <sup>3</sup> / 15.1kg / 1pc	€	<b>501,00</b>

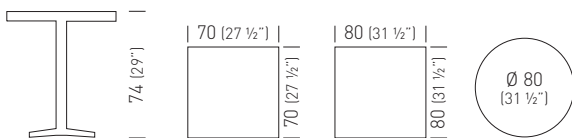

70x70 steel	THUGI217._._/H74		0.17m <sup>3</sup> / 15.0kg / 1pc	€	<b>428,00</b>
80x80 steel	THUGI218._._/H74		0.18m <sup>3</sup> / 16.0kg / 1pc	€	<b>450,00</b>
diam.80 steel	THUGI219._._/H74		0.18m <sup>3</sup> / 13.0kg / 1pc	€	<b>518,00</b>

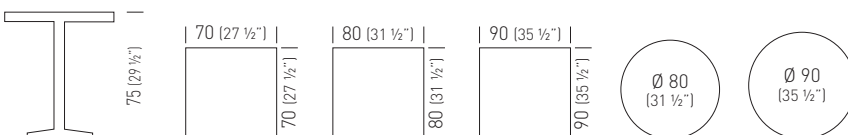

70x70laminated	THUGL220._._/H75		0.17m <sup>3</sup> / 15.1kg / 1pc	€	<b>358,00</b>
80x80laminated	THUGL222._._/H75		0.18m <sup>3</sup> / 17.6kg / 1pc	€	<b>375,00</b>
90x90laminated	THUGL224._._/H75		0.20m <sup>3</sup> / 19.1kg / 1pc	€	<b>409,00</b>
diam.80laminated	THUGL221._._/H75		0.18m <sup>3</sup> / 12.6kg / 1pc	€	<b>460,00</b>
diam.90laminated	THUGL223._._/H75		0.20m <sup>3</sup> / 13.6kg / 1pc	€	<b>498,00</b>

# Hug Marble

Studio Eurolinea Design



The Hug tables collection, made with a 4-star aluminum base, equipped with adjustable feet, is enriched with new Marble tops, thus adapting to the most prestigious installations. The Marble tops, characterized by always different veins of natural stones, contribute to enhance elegance and refinement for the most demanding environments.

The solid Marble surfaces, shiny and glossy, are treated to reduce their porosity, however constant care and cleaning of the product is recommended.

La collezione di tavoli Hug, realizzata con basamento 4 raze in alluminio, dotata di piedini regolabili, si arricchisce di nuovi piani quadrati in Marmo, adattandosi così alle installazioni più prestigiose. I piani in Marmo, caratterizzati dalle sempre diverse venature della pietra naturale, offrono eleganza e raffinatezza, per completare con esclusività gli ambienti più ricercati. I solidi piani in Marmo, splendenti e lucidi, sono trattati per ridurre la porosità, tuttavia si consiglia pulizia costante e cura nell'utilizzo del prodotto.

Frame Color / Colore Struttura

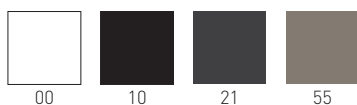

20 mm  
(0.78")  
DOUBLE-RADIUS STRAIGHT-EDGE  
COSTA RETTA BISELLATA



MBC  
BIANCO CARRARA



MNM  
NERO MARQUINA



MVG  
VERDE GUATEMALA



MED  
EMPERADOR DARK

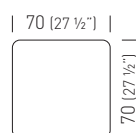
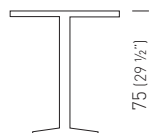

70x70

THUGM215.\_.\_/H74



0.34m³ / 31.1kg / 1pc

€

**798,00**



# Hug Porcelain

Studio Eurolinea Design

The Hug tables collection, made with a 4-star aluminum base, equipped with adjustable feet, is enriched with new Porcelain tops, thus adapting to the most prestigious installations. The Porcelain stoneware tops stand out for their excellent technical performance, ideal for the most delicate uses where maximum hygiene and resistance must be guaranteed. Porcelain tops are compatible with foodstuffs, resistant to fungi and molds, suitable for both indoor and outdoor use, resistant to frost, heat and high temperatures, they can be cleaned very easily while maintaining the characteristics of the surface.

La collezione di tavoli Hug, realizzata con basamento 4 razze in alluminio, dotata di piedini regolabili, si arricchisce di nuovi piani quadrati in Gres Porcellanato, adattandosi così alle installazioni più prestigiose. I piani in Gres Porcellanato si distinguono per le eccellenti performance tecniche, ideali negli impieghi più delicati nei quali è necessario garantire la massima igiene e resistenza. I piani Porcelain sono compatibili con le sostanze alimentari, resistenti a funghi e muffe, idonei ad un utilizzo sia interno che esterno, resistenti al gelo, al calore e alle alte temperature, si possono pulire con estrema facilità mantenendo inalterate le caratteristiche della superficie.



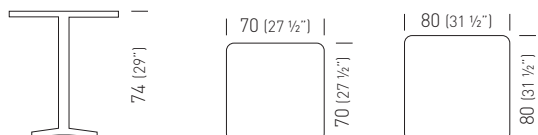
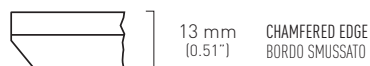
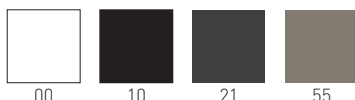

Frame Color / Colore Struttura



70x70  
80x80

THUGP226.\_\_\_\_/H74  
THUGP227.\_\_\_\_/H74

 2.4m<sup>3</sup> / 32.6kg / 1pc  
 2.4m<sup>3</sup> / 39.1kg / 1pc

€ **969,00**  
€ **1003,00**

Min. order 10pcs  
each code  
Ordine min 10pz  
per codice



Frame Color / Colore Struttura

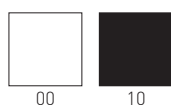

Compactop Color / Colore Piano Compactop



Laminated Top Color / Colore Piano Laminato



Special Finishes / Finiture Speciali

**Compactop:** Special Compactop Surfaces Fullcolor (p. 377) available on demand (min. 5pcs each code).  
Special Compactop Surfaces Fullcolor (p. 377) disponibile su richiesta (min. 5pcs per codice).  
Special Compactop Surfaces 10 (p. 378) available on demand (min. 20pcs each code).  
Special Compactop Surfaces 10 (p. 378) disponibile su richiesta (min. 20pcs per codice).

**Laminated:** Special Laminated Surfaces Wood Effect 25 (p. 383) available on demand (min. 20pcs each code).  
Special Laminated Surfaces Wood Effect 25 (p. 383) disponibile su richiesta (min. 20pcs per codice).  
Special Laminated Surfaces Fenix 25 (p. 384) available on demand (min. 20pcs each code).  
Special Laminated Surfaces Fenix 25 (p. 384) disponibile su richiesta (min. 20pcs per codice).

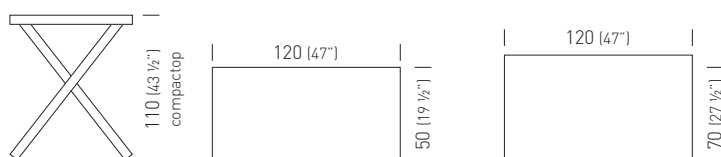

120x50compactop	TICSC830. __- __/H110	0.47m <sup>3</sup> / 25kg / 1pcs	€	<b>676,00</b>
120x50laminated	TICSL836. __- __/H110	0.47m <sup>3</sup> / 25kg / 1pcs	€	<b>529,00</b>
120x70compactop	TICSC832. __- __/H110	0.48m <sup>3</sup> / 26kg / 1pcs	€	<b>705,00</b>
120x70laminated	TICSL838. __- __/H110	0.48m <sup>3</sup> / 26kg / 1pcs	€	<b>626,00</b>

# Link

Stefano Sandonà Design

Waiting areas and Coffee Table,  
painted metal structure suitable  
for outdoor purpose.

Tavolino attesa, struttura in metallo  
verniciato per utilizzo esterno.



Frame Color / Colore Struttura



00



02



10



21

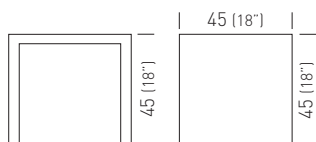

45x45

TLNKI025\_/\_/H45



0.18m<sup>3</sup> / 7kg / 1pcs

€

**198,00**

# Login

Studio Eurolinea Design



Table with co-injected metal frame with techno polymer, wooden legs, Laminated Top.  
Tavolo con struttura in metallo sovrastampato con tecnopolimero, gambe in legno massello di faggio o rovere, piani in Laminato.

## Frame Color / Colore Struttura

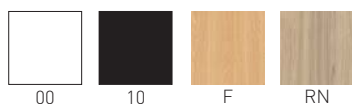

## Laminated Top Color / Colore Piano Laminato



## Special Finishes / Finiture Speciali

**Laminated:** Special Laminated Surfaces Wood Effect 25 (p. 383) available on demand (min. 20pcs each code)  
Special Laminated Surfaces Wood Effect 25 (p. 383) disponibile su richiesta (min. 20pcs per codice)  
Special Laminated Surfaces Fenix 25 (p. 384) available on demand (min. 20pcs each code)  
Special Laminated Surfaces Fenix 25 (p. 384) disponibile su richiesta (min. 20pcs per codice)

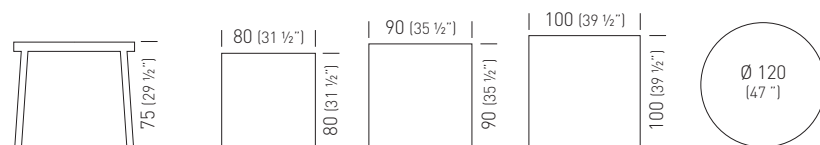

80x80laminated	TLOGL230._____/H75	0.35m <sup>3</sup> / 21kg / 1pcs	€	<b>555,00</b>
90x90laminated	TLOGL232._____/H75	0.46m <sup>3</sup> / 22kg / 1pcs	€	<b>581,00</b>
100x100laminated	TLOGL234._____/H75	0.46m <sup>3</sup> / 24kg / 1pcs	€	<b>637,00</b>
diam. 120laminated	TLOGL236._____/H75	0.80m <sup>3</sup> / 26kg / 1pcs	€	<b>747,00</b>

# Lol

Forsix Design

The "Lol" table collection is intended for outdoor use; youthfully simple and sunny, its design blends in discreetly with either the most sparkling or the most sober environments. The table tops with composite material core, as well as the bases, available with three or four spokes, are made up of a metal structure treated for outdoor use, and with a matt finish. The available colour palette is common to many Gaber seating collections, guaranteeing tone-on-tone colour co-ordination throughout designed settings rather than lively contrasts, defining various colour combinations between bases, tops and seating.

La collezione di tavoli Lol, disegnata da Forsix, è ideale per l'utilizzo all'aria aperta: giovane, semplice e solare, il suo design si fonde con discrezione dagli ambienti più sobri a quelli più frizzanti. I piani del tavolo, dal cuore in materiale composito, come anche i basamenti, disponibili a tre o quattro razze, sono costituiti da una struttura in metallo trattata per esterni, dalla finitura opaca. La palette di colori disponibile è comune a molte collezioni di sedute Gaber, garantendo abbinamenti tono su tono degli ambienti progettati, piuttosto che vivaci contrasti, definendo diverse combinazioni di colori tra basi, piani e sedute.



Colors / Colori

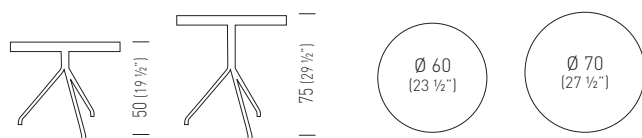
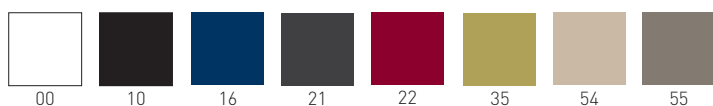

diam.60	TLL3I034._._/H50	0.19m³ / 10.30kg / 1pc	€ <b>329,00</b>
diam.70	TLL3I036._._/H50	0.19m³ / 10.70kg / 1pc	€ <b>338,00</b>
diam.60	TLL3I034._._/H75	0.26m³ / 10.90kg / 1pc	€ <b>335,00</b>
diam.70	TLL3I036._._/H75	0.26m³ / 11.30kg / 1pc	€ <b>343,00</b>

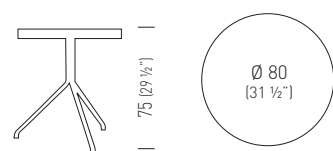

diam.80	TLL3I038._._/H75	0.45m³ / 12.00kg / 1pc	€ <b>357,00</b>
---------	------------------	------------------------	-----------------

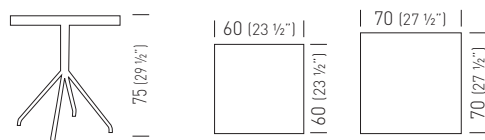

60x60	TLL4I035._._/H75	0.26m³ / 13.00kg / 1pc	€ <b>336,00</b>
70x70	TLL4I037._._/H75	0.26m³ / 14.60kg / 1pc	€ <b>344,00</b>

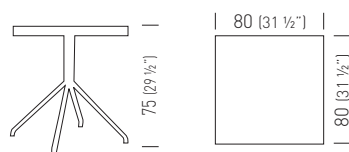

80x80	TLL4I039._._/H75	0.38m³ / 16.30kg / 1pc	€ <b>367,00</b>
-------	------------------	------------------------	-----------------

# Lol Plus

Forsix Design



The Lol Plus tables collection is made of steel, the cross is made in aluminum, and provided with flip-top joint. The shape of the base and the flip-top mechanism allow the table to easily fold and stack, space-saving. The available colour palette is common to many Gaber seating collections, guaranteeing tone-on-tone colour co-ordination throughout designed settings rather than lively contrasts, defining various colour combinations between bases, tops and seating.

La Collezione di tavoli Lol Plus è realizzata in acciaio, la crociera è realizzata in alluminio, ed è dotata di giunto per la rotazione del piano. La forma della base e la meccanica che permette la rotazione del piano in posizione verticale, rendono il tavolo facilmente accatastabile in spazi ridotti. La palette di colori disponibile è comune a molte collezioni di sedute Gaber, garantendo abbinamenti tono su tono degli ambienti progettati, piuttosto che vivaci contrasti, definendo diverse combinazioni di colori tra basi, piani e sedute.

Frame Color / Colore Struttura

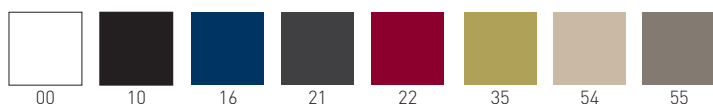

diam.60	TLLPI034._._/H75	 0.26m <sup>3</sup> / 12.10kg / 1pc	€	<b>361,00</b>
60x60	TLLPI035._._/H75	 0.26m <sup>3</sup> / 13.50kg / 1pc	€	<b>370,00</b>

# Lol Marble

Forsix Design

The Lol tables collection is enriched with new Marble tops, with round or square shapes, thus adapting to the most prestigious installations. The Marble tops, characterized by always different veins of natural stones, contribute to enhance elegance and refinement for the most demanding environments. The solid Marble surfaces, shiny and glossy, are treated to reduce their porosity, however constant care and cleaning of the product is recommended. La collezione di tavoli Lol si arricchisce di nuovi piani in Marmo, dalle forme rotonde o quadrate, adattandosi così alle più prestigiose installazioni. I piani in Marmo, caratterizzati dalle sempre diverse venature della pietra naturale, offrono eleganza e raffinatezza, per completare con esclusività gli ambienti più ricercati. I solidi piani in Marmo, splendenti e lucidi, sono trattati per ridurre la porosità, tuttavia si consiglia pulizia costante e cura nell'utilizzo del prodotto.



Frame Color / Colore Struttura

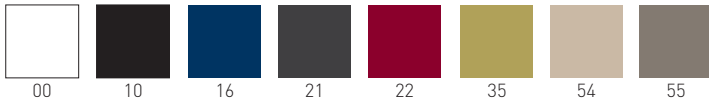

20 mm  
(0.78")  
DOUBLE-RADIUS STRAIGHT-EDGE  
COSTA RETTA BISELLATA



MBC  
BIANCO CARRARA



MNM  
NERO MARQUINA



MVG  
VERDE GUATEMALA



MED  
EMPERADOR DARK

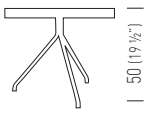

diam.60  
diam.70

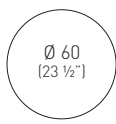

Ø 60  
(23 1/2")

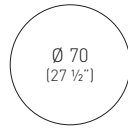

Ø 70  
(27 1/2")

TLL3M238.\_.\_/H50  
TLL3M240.\_.\_/H50

0.37m³ / 20kg / 1pc  
 0.37m³ / 25kg / 1pc

€ **591,00**  
€ **701,00**

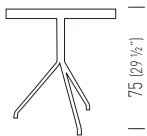

diam.60  
diam.70  
diam.80

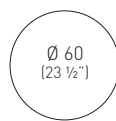

Ø 60  
(23 1/2")

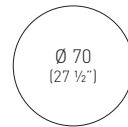

Ø 70  
(27 1/2")

TLL3M238.\_.\_/H75  
TLL3M240.\_.\_/H75  
TLL3M242.\_.\_/H75

0.44m³ / 20.6kg / 1pc  
 0.44m³ / 25.6kg / 1pc  
 0.63m³ / 31.7kg / 1pc

€ **594,00**  
€ **704,00**  
€ **842,00**

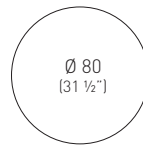

Ø 80  
(31 1/2")

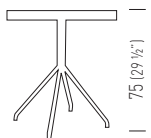

60x60  
70x70

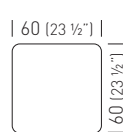

| 60 (23 1/2") |

| 60 (23 1/2") |

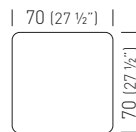

| 70 (27 1/2") |

| 70 (27 1/2") |

TLL4M239.\_.\_/H75  
TLL4M241.\_.\_/H75

0.44m³ / 25.5kg / 1pc  
 0.44m³ / 32kg / 1pc

€ **594,00**  
€ **704,00**

# Lol Porcelain

Forsix Design



The Lol tables collection is enriched with new Porcelain tops, with round or square shapes, thus adapting to the most prestigious installations. The Porcelain stoneware tops stand out for their excellent technical performance, ideal for the most delicate uses where maximum hygiene and resistance must be guaranteed. Porcelain tops are compatible with foodstuffs, resistant to fungi and molds, suitable for both indoor and outdoor use, resistant to frost, heat and high temperatures, they can be cleaned very easily while maintaining the characteristics of the surface.

La collezione di tavoli Lol si arricchisce di nuovi piani in Gres Porcellanato, dalle forme rotonde o quadrate, adattandosi così alle più prestigiose installazioni. I piani in Gres Porcellanato si distinguono per le eccellenti performance tecniche, ideali negli impieghi più delicati nei quali è necessario garantire la massima igiene e resistenza.

I piani Porcelain sono compatibili con le sostanze alimentari, resistenti a funghi e muffe, idonei ad un utilizzo sia interno che esterno, resistenti al gelo, al calore a alle alte temperature, si possono pulire con estrema facilità mantenendo inalterate le caratteristiche della superficie.

Frame Color / Colore Struttura

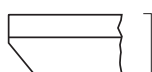
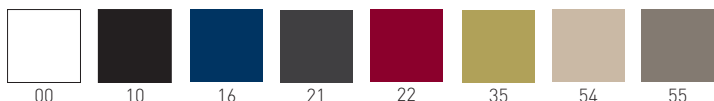

13 mm  
(0.51") CHAMFERED EDGE  
BORDO SMUSSATO



PCO  
CALACATTA ORO



PNG  
NERO GRECO

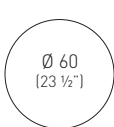
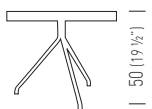

Ø 60  
(23 1/2")

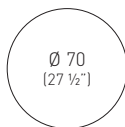

Ø 70  
(27 1/2")

diam.60  
diam.70

TLL3P244.\_.\_/H50  
TLL3P246.\_.\_/H50

0.87m<sup>3</sup> / 23.8kg / 1pc  
 0.87m<sup>3</sup> / 27kg / 1pc

€ **730,00**  
€ **868,00**

Min. order 10pcs  
each code  
Ordine min 10pz  
per codice

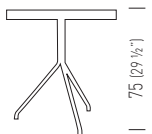

Ø 60  
(23 1/2")

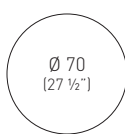

Ø 70  
(27 1/2")

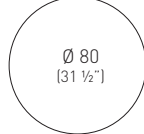
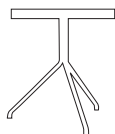

Ø 80  
(31 1/2")

diam.60  
diam.70  
diam.80

TLL3P244.\_.\_/H75  
TLL3P246.\_.\_/H75  
TLL3P248.\_.\_/H75

0.94m<sup>3</sup> / 24.4kg / 1pc  
 0.94m<sup>3</sup> / 27.6kg / 1pc  
 1.13m<sup>3</sup> / 32.2kg / 1pc

€ **738,00**  
€ **873,00**  
€ **1008,00**

Min. order 10pcs  
each code  
Ordine min 10pz  
per codice

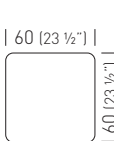
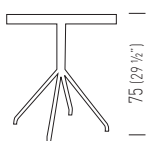

60 (23 1/2")

60 (23 1/2")

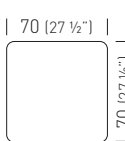

70 (27 1/2")

70 (27 1/2")

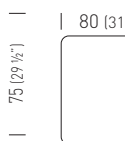

80 (31 1/2")

80 (31 1/2")

60x60  
70x70  
80x80

TLL4P245.\_.\_/H75  
TLL4P247.\_.\_/H75  
TLL4P249.\_.\_/H75

0.94m<sup>3</sup> / 28.5kg / 1pc  
 0.94m<sup>3</sup> / 31.5kg / 1pc  
 1.05m<sup>3</sup> / 29.1kg / 1pc

€ **648,00**  
€ **891,00**  
€ **905,00**

Min. order 10pcs  
each code  
Ordine min 10pz  
per codice



# Minush

Studio Eurolinea Design

The Minush stackable coffee table, made of technopolymer, takes up the lines of some collections of Gaber chairs and sunbeds, but suit perfectly any outdoor seat as a practical support for small objects.

Il tavolino impilabile Minush, realizzato in tecnopolimero, riprende le linee di alcune collezioni di sedute e lettini Gaber, ma ben si adatta ad accompagnare qualunque seduta da esterno come pratico appoggio per piccoli oggetti.



Technopolymer Frame Color / Colore Struttura Tecnopolimero

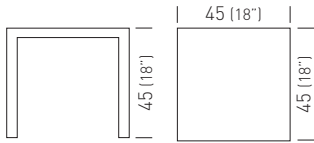
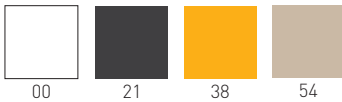

45x45

TMINT024.\_/H45



0.13m<sup>3</sup> / 8kg / 2pcs

€

**129,00**



230V - 50Hz  
1 X 16W - Led Modul  
IP 65

H75 Table with Compactop, Technopolymer base.  
Available illuminated and suitable for outdoor use.  
Tavolo realizzato con piano in Compactop H75  
e struttura in tecnopolimero.  
Disponibile con versione luminosa  
e adatti all'uso esterno.

Technopolymer Base Color / Colore Base Tecnopolimero

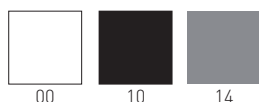

Led version with white transparent base.  
Versione led con base in bianco trasparente.

Compactop Color / Colore Piano Compactop

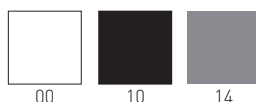

Special Finishes / Finiture Speciali

**Compactop:** Special Compactop Surfaces Fullcolor (p.377) white available on demand (min. 5pcs each code).  
Special Compactop Surfaces Fullcolor (p.377) bianco disponibile su richiesta (min. 5pcs per codice).

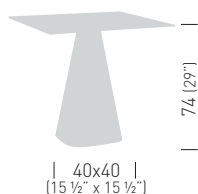

base74	BMUG.__/H74		0.13m <sup>3</sup> / 12.5kg / 1pcs	€	<b>169,00</b>	
base74 Led	BMUG.__/H74L		0.13m <sup>3</sup> / 14.7kg / 1pcs	€	<b>508,00</b>	
base74+20	BMUG.__/H74+20		0.13m <sup>3</sup> / 32.5kg / 1pcs	€	<b>208,00</b>	
Ø 60 (23 1/2")	TMUGC170.___/H74		0.21m <sup>3</sup> / 18.0kg / 1pcs	€	<b>367,00</b>	
diam.60 Led	TMUGC170.___/H74L		0.21m <sup>3</sup> / 20.2kg / 1pcs	€	<b>705,00</b>	
diam.60+20	TMUGC170.___/H74+20		0.21m <sup>3</sup> / 38.0kg / 1pcs	€	<b>406,00</b>	
Ø 68 (27")	TMUGC178.___/H74		0.23m <sup>3</sup> / 21.5kg / 1pcs	€	<b>406,00</b>	
diam.68 Led	TMUGC178.___/H74L		0.23m <sup>3</sup> / 23.7kg / 1pcs	€	<b>746,00</b>	
diam.68+20	TMUGC178.___/H74+20		0.23m <sup>3</sup> / 41.5kg / 1pcs	€	<b>445,00</b>	
Ø 80 (31 1/2")	TMUGC186.___/H74		0.5m <sup>3</sup> / 23.5kg / 1pcs	€	<b>445,00</b>	
diam.80 Led	TMUGC186.___/H74L		0.5m <sup>3</sup> / 25.7kg / 1pcs	€	<b>784,00</b>	
diam.80+20	TMUGC186.___/H74+20		0.5m <sup>3</sup> / 43.5kg / 1pcs	€	<b>484,00</b>	
Ø 100 (39 1/2")	TMUGC198.___/H74		0.67m <sup>3</sup> / 28.0kg / 1pcs	€	<b>581,00</b>	
diam.100 Led	TMUGC198.___/H74L		0.67m <sup>3</sup> / 32.2kg / 1pcs	€	<b>857,00</b>	
diam.100+20	TMUGC198.___/H74+20		0.67m <sup>3</sup> / 48.0kg / 1pcs	€	<b>620,00</b>	
60 (23 1/2")	60x60	TMUGC174.___/H74		0.21m <sup>3</sup> / 20.0kg / 1pcs	€	<b>326,00</b>
60 (23 1/2")	60x60 Led	TMUGC174.___/H74L		0.21m <sup>3</sup> / 22.5kg / 1pcs	€	<b>667,00</b>
60 (23 1/2")	60x60+20	TMUGC174.___/H74+20		0.21m <sup>3</sup> / 39.5kg / 1pcs	€	<b>367,00</b>
68 (27")	68x68	TMUGC182.___/H74		0.23m <sup>3</sup> / 21.8kg / 1pcs	€	<b>352,00</b>
68 (27")	68x68 Led	TMUGC182.___/H74L		0.23m <sup>3</sup> / 24.0kg / 1pcs	€	<b>688,00</b>
68 (27")	68x68+20	TMUGC182.___/H74+20		0.23m <sup>3</sup> / 41.8kg / 1pcs	€	<b>391,00</b>
79 (31")	79x79	TMUGC190.___/H74		0.50m <sup>3</sup> / 25.0kg / 1pcs	€	<b>375,00</b>
79 (31")	79x79 Led	TMUGC190.___/H74L		0.50m <sup>3</sup> / 27.0kg / 1pcs	€	<b>715,00</b>
79 (31")	79x79+20	TMUGC190.___/H74+20		0.50m <sup>3</sup> / 45.0kg / 1pcs	€	<b>414,00</b>
89 (35")	89x89	TMUGC194.___/H74		0.60m <sup>3</sup> / 26.0kg / 1pcs	€	<b>488,00</b>
89 (35")	89x89 Led	TMUGC194.___/H74L		0.60m <sup>3</sup> / 28.0kg / 1pcs	€	<b>787,00</b>
89 (35")	89x89+20	TMUGC194.___/H74+20		0.60m <sup>3</sup> / 46.0kg / 1pcs	€	<b>527,00</b>

# Norman

Forsix Design

The Norman table collection is made using basic geometries to achieve distinctly shapes. Available with round or square Laminated, Compactop or Marble tops, Norman utilizes a 4 legged aluminum frame, available in many vibrant colours.

La collezione di Tavoli Norman è realizzata utilizzando geometrie semplici e forme essenziali. Disponibile con piani rotondi o quadrati in Laminato, Compactop o Marmo, Norman utilizza una struttura 4 gambe in alluminio, disponibile in vari colori di tendenza.



Only for Compactop and Steel tops  
Solo per piani in compactop e acciaio



## Frame Color / Colore Struttura



## Compactop Color / Colore Piano Compactop



## Laminated Top Color / Colore Piano Laminato



## Special Finishes / Finiture Speciali

**Compactop:** Standard Compactop Surfaces 10 (p. 376) available on demand (min. 20pcs each code)  
Standard Compactop Surfaces 10 (p. 376) disponibile su richiesta (min. 20pcs per codice)  
Special Compactop Surfaces Fullcolor (p.377) white available on demand (min. 5pcs each code).  
Special Compactop Surfaces Fullcolor (p.377) bianco disponibile su richiesta (min. 5pcs per codice).

**Laminated:** Special Laminated Surfaces Wood Effect 25 (p. 383) available on demand (min. 20pcs each code)  
Special Laminated Surfaces Wood Effect 25 (p. 383) disponibile su richiesta (min. 20pcs per codice)  
Special Laminated Surfaces Fenix 25 (p. 384) available on demand (min. 20pcs each code)  
Special Laminated Surfaces Fenix 25 (p. 384) disponibile su richiesta (min. 20pcs per codice)

## Steel Top Color / Colori Top Steel



## Laminated / Laminato

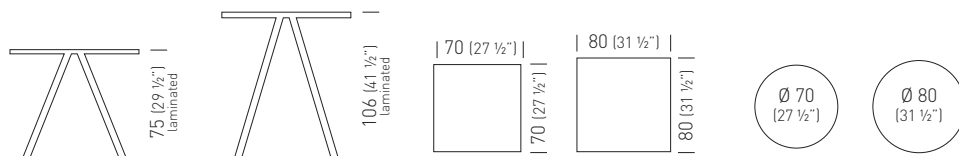

70x70	TNORL481. __-_/H74	0.20m <sup>3</sup> / 16.20kg / 1pc	€	<b>302,00</b>
80x80	TNORL483. __-_/H74	0.22m <sup>3</sup> / 18.70kg / 1pc	€	<b>344,00</b>
diam.70	TNORL480. __-_/H74	0.20m <sup>3</sup> / 13.20kg / 1pc	€	<b>344,00</b>
diam.80	TNORL482. __-_/H74	0.22m <sup>3</sup> / 16.70kg / 1pc	€	<b>454,00</b>
70x70	TNORL481. __-_/H105	0.20m <sup>3</sup> / 17.34kg / 1pc	€	<b>336,00</b>
80x80	TNORL483. __-_/H105	0.22m <sup>3</sup> / 19.84kg / 1pc	€	<b>378,00</b>
diam.70	TNORL480. __-_/H105	0.20m <sup>3</sup> / 14.34kg / 1pc	€	<b>378,00</b>
diam.80	TNORL482. __-_/H105	0.22m <sup>3</sup> / 17.84kg / 1pc	€	<b>471,00</b>



Only for Compactop and Steel tops  
Solo per piani in compactop e acciaio

## Frame Color / Colore Struttura



## Compactop Color / Colore Piano Compactop

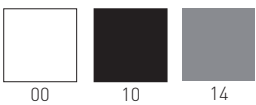

## Laminated Top Color / Colore Piano Laminato



## Steel Top Color / Colori Top Steel

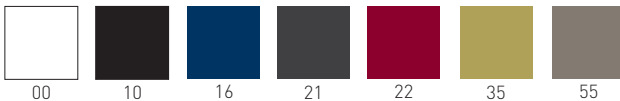

## Special Finishes / Finiture Speciali

**Compactop:** Standard Compactop Surfaces 10 (p. 376) available on demand (min. 20pcs each code)  
Standard Compactop Surfaces 10 (p. 376) disponibile su richiesta (min. 20pcs per codice)  
Special Compactop Surfaces Fullcolor (p.377) white available on demand (min. 5pcs each code).  
Special Compactop Surfaces Fullcolor (p.377) bianco disponibile su richiesta (min. 5pcs per codice).

**Laminated:** Special Laminated Surfaces Wood Effect 25 (p. 383) available on demand (min. 20pcs each code)  
Special Laminated Surfaces Wood Effect 25 (p. 383) disponibile su richiesta (min. 20pcs per codice)  
Special Laminated Surfaces Fenix 25 (p. 384) available on demand (min. 20pcs each code)  
Special Laminated Surfaces Fenix 25 (p. 384) disponibile su richiesta (min. 20pcs per codice)

## Compactop / Compactop

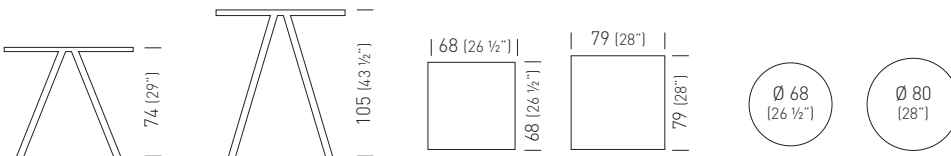

68x68	TNORC472._._/H74	0.20m <sup>3</sup> / 16.20kg / 1pc	€ <b>361,00</b>
79x79	TNORC476._._/H74	0.22m <sup>3</sup> / 16.70kg / 1pc	€ <b>386,00</b>
diam.68	TNORC470._._/H74	0.20m <sup>3</sup> / 13.20kg / 1pc	€ <b>394,00</b>
diam.80	TNORC474._._/H74	0.22m <sup>3</sup> / 16.30kg / 1pc	€ <b>454,00</b>
68x68	TNORC472._._/H105	0.20m <sup>3</sup> / 17.34kg / 1pc	€ <b>395,00</b>
79x79	TNORC476._._/H105	0.22m <sup>3</sup> / 17.84kg / 1pc	€ <b>420,00</b>
diam.68	TNORC470._._/H105	0.20m <sup>3</sup> / 14.34kg / 1pc	€ <b>428,00</b>
diam.80	TNORC474._._/H105	0.22m <sup>3</sup> / 17.44kg / 1pc	€ <b>488,00</b>

## Steel / Acciaio

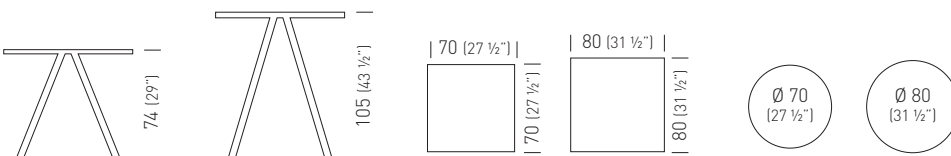

70x70	TNORI486._._/H74	0.20m <sup>3</sup> / 19.20kg / 1pc	€ <b>394,00</b>
80x80	TNORI488._._/H74	0.22m <sup>3</sup> / 20.20kg / 1pc	€ <b>505,00</b>
diam.70	TNORI485._._/H74	0.20m <sup>3</sup> / 16.20kg / 1pc	€ <b>389,00</b>
diam.80	TNORI487._._/H74	0.22m <sup>3</sup> / 21.20kg / 1pc	€ <b>494,00</b>
70x70	TNORI486._._/H105	0.20m <sup>3</sup> / 20.34kg / 1pc	€ <b>428,00</b>
80x80	TNORI488._._/H105	0.22m <sup>3</sup> / 21.34kg / 1pc	€ <b>539,00</b>
diam.70	TNORI485._._/H105	0.20m <sup>3</sup> / 17.34kg / 1pc	€ <b>423,00</b>
diam.80	TNORI487._._/H105	0.22m <sup>3</sup> / 22.34kg / 1pc	€ <b>529,00</b>

# Norman Marble

Forsix Design

The Norman table collection utilizes a 4 legged aluminum frame, available in many vibrant colours. The Marble tops, characterized by always different veins of natural stones, contribute to enhance elegance and refinement for the most demanding environments. The solid Marble surfaces, shiny and glossy, are treated to reduce their porosity, however constant care and cleaning of the product is recommended.

La collezione di Tavoli Norman utilizza una struttura 4 gambe in alluminio, disponibile in vari colori di tendenza. I piani in Marmo, caratterizzati dalle sempre diverse venature della pietra naturale, offrono eleganza e raffinatezza, per completare con esclusività gli ambienti più ricercati. I solidi piani in Marmo, splendenti e lucidi, sono trattati per ridurre la porosità, tuttavia si consiglia pulizia costante e cura nell'utilizzo del prodotto.



Frame Color / Colore Struttura

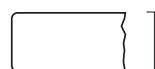
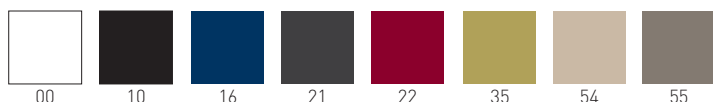

20 mm  
(0.78")  
DOUBLE-RADIUS STRAIGHT-EDGE  
COSTA RETTA BISELLATA



MBC  
BIANCO CARRARA



MNM  
NERO MARQUINA



MVG  
VERDE GUATEMALA



MED  
EMPERADOR DARK

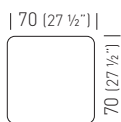
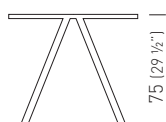

70x70	TNORM491. __- __/H75		0.34m³ / 30.20kg / 1pc	€	<b>660,00</b>
diam.70	TNORM490. __- __/H75		0.34m³ / 24.70kg / 1pc	€	<b>660,00</b>
diam.80	TNORM492. __- __/H75		0.34m³ / 30.70kg / 1pc	€	<b>756,00</b>

# Pareo

Forsix Design



Only for compactop  
solo per compactop

The Pareo Collection offers a wide range of beautifully designed dining and coffee tables. Thanks to their clean yet detailed design, Pareo tables suit a variety of hospitality settings, available in square, rectangular and round versions. The aluminum table frame, combined with Compact or Porcelain table tops, fits perfectly into even outdoor environments. Pareo Tables are made to be easily assembled and are available in a wide variety of bright frame colours and top finishes, perfectly matching your custom projects.

La collezione Pareo offre una vasta gamma di tavoli e tavolini dal design accattivante. Grazie alle loro linee essenziali e curate, i tavoli Pareo si adattano a diversi stili dedicati all'ospitalità e sono disponibili nella versione quadrata, rettangolare o rotonda. La struttura del tavolo, realizzata in alluminio, abbinata ai piani in Compactop o Gres, si adatta perfettamente anche agli ambienti esterni. I tavoli Pareo sono realizzati per essere facilmente e velocemente assemblati e sono disponibili in un'ampia varietà di colori e finiture, perfetti per i vostri progetti personalizzati.

## Frame Color / Colore Struttura

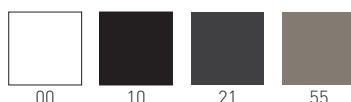

## Compactop Color / Colore Piano Compactop

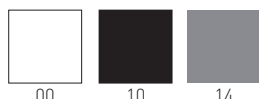

## Special Finishes / Finiture Speciali

**Compactop:** Special Compactop Surfaces Fullcolor (p. 377) available on demand (min. 5pcs each code).  
Special Compactop Surfaces Fullcolor (p. 377) disponibile su richiesta (min. 5pcs per codice).  
Special Compactop Surfaces 10 (p. 378) available on demand (min. 20pcs each code).  
Special Compactop Surfaces 10 (p. 378) disponibile su richiesta (min. 20pcs per codice).

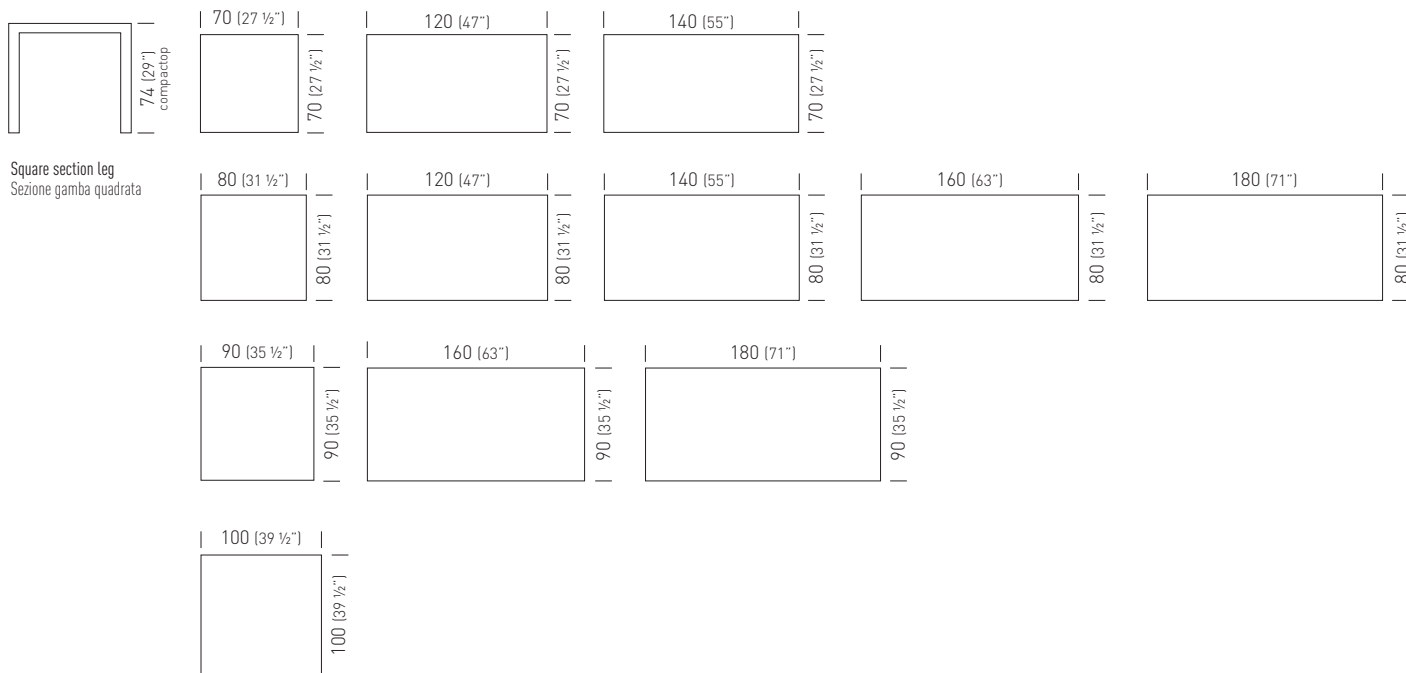

70x70compactop	TPAQC700._._/H74		0.09m <sup>3</sup> / 19.30kg / 1pc	€	<b>380,00</b>
80x80compactop	TPAQC708._._/H74		0.10m <sup>3</sup> / 19.80kg / 1pc	€	<b>437,00</b>
90x90compactop	TPAQC718._._/H74		0.16m <sup>3</sup> / 22.30kg / 1pc	€	<b>504,00</b>
100x100compactop	TPAQC728._._/H74		0.19m <sup>3</sup> / 26.30kg / 1pc	€	<b>572,00</b>
120x70compactop	TPAQC702._._/H74		0.29m <sup>3</sup> / 36.80kg / 1pc	€	<b>552,00</b>
120x80compactop	TPAQC710._._/H74		0.29m <sup>3</sup> / 39.30kg / 1pc	€	<b>609,00</b>
140x70compactop	TPAQC704._._/H74		0.29m <sup>3</sup> / 41.80kg / 1pc	€	<b>729,00</b>
140x80compactop	TPAQC712._._/H74		0.29m <sup>3</sup> / 43.10kg / 1pc	€	<b>784,00</b>
160x80compactop	TPAQC714._._/H74		0.30m <sup>3</sup> / 45.80kg / 1pc	€	<b>956,00</b>
160x90compactop	TPAQC724._._/H74		0.30m <sup>3</sup> / 48.80kg / 1pc	€	<b>1032,00</b>
180x80compactop	TPAQC716._._/H74		0.30m <sup>3</sup> / 48.80kg / 1pc	€	<b>1028,00</b>
180x90compactop	TPAQC726._._/H74		0.30m <sup>3</sup> / 51.80kg / 1pc	€	<b>1122,00</b>

# Pareo

Forsix Design

The Pareo Collection offers a wide range of beautifully designed dining and coffee tables. Thanks to their clean yet detailed design, Pareo tables suit a variety of hospitality settings, available in square, rectangular and round versions. The aluminum table frame, combined with Compact or Porcelain table tops, fits perfectly into even outdoor environments. Pareo Tables are made to be easily assembled and are available in a wide variety of bright frame colours and top finishes, perfectly matching your custom projects.

La collezione Pareo offre una vasta gamma di tavoli e tavolini dal design accattivante. Grazie alle loro linee essenziali e curate, i tavoli Pareo si adattano a diversi stili dedicati all'ospitalità e sono disponibili nella versione quadrata, rettangolare o rotonda. La struttura del tavolo, realizzata in alluminio, abbinata ai piani in Compactop o Gres, si adatta perfettamente anche agli ambienti esterni. I tavoli Pareo sono realizzati per essere facilmente e velocemente assemblati e sono disponibili in un'ampia varietà di colori e finiture, perfetti per i vostri progetti personalizzati.



## Frame Color / Colore Struttura

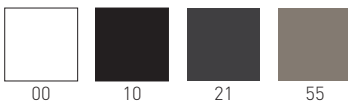

## Laminated Top Color / Colore Piano Laminato



## Special Finishes / Finiture Speciali

**Laminated:** Special Laminated Surfaces Wood Effect 25 (p. 383) available on demand (min. 20pcs each code)  
Special Laminated Surfaces Wood Effect 25 (p. 383) disponibile su richiesta (min. 20pcs per codice)  
Special Laminated Surfaces Fenix 25 (p. 384) available on demand (min. 20pcs each code)  
Special Laminated Surfaces Fenix 25 (p. 384) disponibile su richiesta (min. 20pcs per codice)

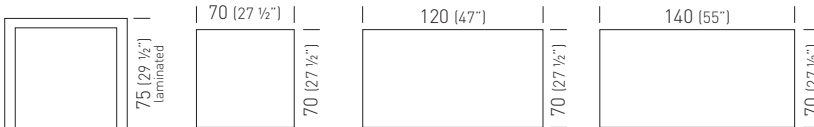

## Square section leg Sezione gamba quadrata

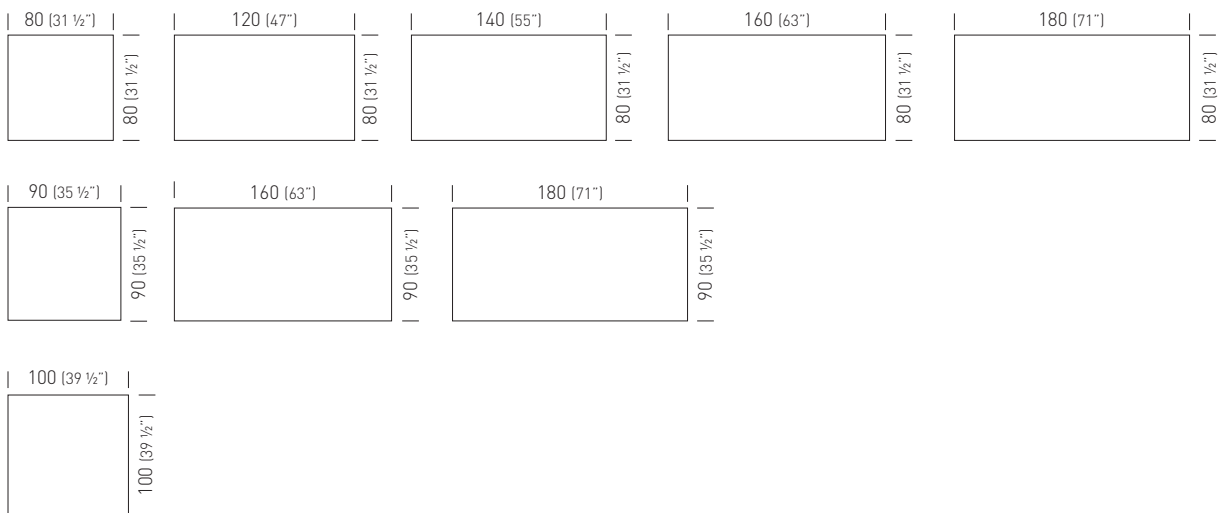

70x70laminated	TPAQL740._._/H74		0.09m <sup>3</sup> / 19.30kg / 1pc	€	<b>346,00</b>
80x80laminated	TPAQL744._._/H74		0.10m <sup>3</sup> / 21.80kg / 1pc	€	<b>403,00</b>
90x90laminated	TPAQL749._._/H74		0.16m <sup>3</sup> / 23.30kg / 1pc	€	<b>470,00</b>
100x100laminated	TPAQL754._._/H74		0.19m <sup>3</sup> / 23.80kg / 1pc	€	<b>538,00</b>
120x70laminated	TPAQL741._._/H74		0.30m <sup>3</sup> / 35kg / 1pc	€	<b>518,00</b>
120x80laminated	TPAQL745._._/H74		0.30m <sup>3</sup> / 37.80kg / 1pc	€	<b>575,00</b>
140x70laminated	TPAQL742._._/H74		0.31m <sup>3</sup> / 39.80kg / 1pc	€	<b>694,00</b>
140x80laminated	TPAQL746._._/H74		0.31m <sup>3</sup> / 39.80kg / 1pc	€	<b>750,00</b>
160x80laminated	TPAQL747._._/H74		0.31m <sup>3</sup> / 40.80kg / 1pc	€	<b>922,00</b>
160x90laminated	TPAQL752._._/H74		0.31m <sup>3</sup> / 42.80kg / 1pc	€	<b>997,00</b>
180x80laminated	TPAQL748._._/H74		0.32m <sup>3</sup> / 42.80kg / 1pc	€	<b>994,00</b>
180x90laminated	TPAQL753._._/H74		0.32m <sup>3</sup> / 45.30kg / 1pc	€	<b>1088,00</b>

# Pareo

Forsix Design



Only for compactop  
solo per compactop

## Frame Color / Colore Struttura

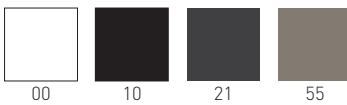

## Compactop Color / Colore Piano Compactop

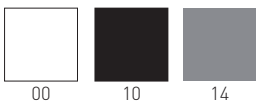

## Laminated Top Color / Colore Piano Laminato



## Special Finishes / Finiture Speciali

**Compactop:** Special Compactop Surfaces Fullcolor (p. 377) available on demand (min. 5pcs each code).  
Special Compactop Surfaces Fullcolor (p. 377) disponibile su richiesta (min. 5pcs per codice).  
Special Compactop Surfaces 10 (p. 378) available on demand (min. 20pcs each code).  
Special Compactop Surfaces 10 (p. 378) disponibile su richiesta (min. 20pcs per codice).

**Laminated:** Special Laminated Surfaces Wood Effect 25 (p. 383) available on demand (min. 20pcs each code).  
Special Laminated Surfaces Wood Effect 25 (p. 383) disponibile su richiesta (min. 20pcs per codice).  
Special Laminated Surfaces Fenix 25 (p. 384) available on demand (min. 20pcs each code).  
Special Laminated Surfaces Fenix 25 (p. 384) disponibile su richiesta (min. 20pcs per codice).



Round section leg  
Sezione gamba rotonda

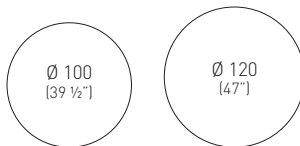

diam.100compactop	TPARC730.___/H74		0.30m <sup>3</sup> / 38.30kg / 1pc	€	<b>597,00</b>
diam.120compactop	TPARC732.___/H74		0.30m <sup>3</sup> / 43.80kg / 1pc	€	<b>648,00</b>
diam.100laminated	TPARL755.___/H74		0.28m <sup>3</sup> / 32.80kg / 1pc	€	<b>563,00</b>
diam.120laminated	TPARL756.___/H74		0.29m <sup>3</sup> / 36.30kg / 1pc	€	<b>614,00</b>



# Pareo Marble

Forsix Design

The Pareo Marble tables utilizes a resistant aluminum and steel frame, fast and easy to assemble. The Marble tops, characterized by always different veins of natural stones, contribute to enhance elegance and refinement for the most demanding environments. The solid Marble surfaces, shiny and glossy, are treated to reduce their porosity, however constant care and cleaning of the product is recommended.

La collezione tavoli Pareo Marble utilizza un resistente telaio in alluminio e acciaio, facile ed intuitivo nell'assemblaggio. I piani in Marmo, caratterizzati dalle sempre diverse venature della pietra naturale, offrono eleganza e raffinatezza, per completare con esclusività gli ambienti più ricercati. I solidi piani in Marmo, splendenti e lucidi, sono trattati per ridurne la porosità, tuttavia si consiglia pulizia costante e cura nell'utilizzo del prodotto.



Frame Color / Colore Struttura

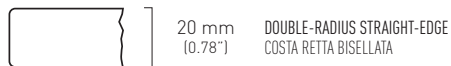
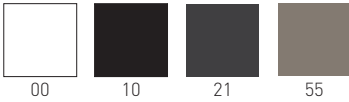

20 mm  
(0.78")  
DOUBLE-RADIUS STRAIGHT-EDGE  
COSTA RETTA BISELLATA



MBC  
BIANCO CARRARA



MNM  
NERO MARQUINA



MVG  
VERDE GUATEMALA



MED  
EMPERADOR DARK

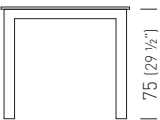

Round section leg  
Sezione gamba rotonda

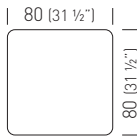

80x80

TPARM760. \_- \_/H74



0.97m³ / 57.80kg / 1pc



818,00

# Pareo Porcelain

Forsix Design



The Pareo Porcelain tables utilizes a resistant aluminum and steel frame, fast and easy to assemble. The Porcelain stoneware tops stand out for their excellent technical performance, ideal for the most delicate uses where maximum hygiene and resistance must be guaranteed. Porcelain tops are compatible with foodstuffs, resistant to fungi and molds, suitable for both indoor and outdoor use, resistant to frost, heat and high temperatures, they can be cleaned very easily while maintaining the characteristics of the surface.

La collezione tavoli Pareo Porcelain utilizza un resistente telaio in alluminio e acciaio, facile ed intuitivo nell'assemblaggio. I piani in Gres Porcellanato si distinguono per le eccellenti performance tecniche, ideali negli impieghi più delicati nei quali è necessario garantire la massima igiene e resistenza. I piani Porcelain sono compatibili con le sostanze alimentari, resistenti a funghi e muffe, idonei ad un utilizzo sia interno che esterno, resistenti al gelo, al calore a alle alte temperature, si possono pulire con estrema facilità mantenendo inalterate le caratteristiche della superficie.

Frame Color / Colore Struttura

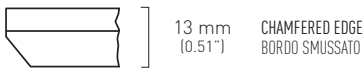
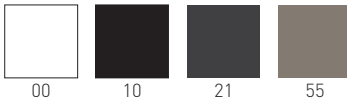

13 mm  
(0.51") CHAMFERED EDGE  
BORDO SMUSSATO



PCO  
CALACATTA ORO



PNG  
NERO GRECO

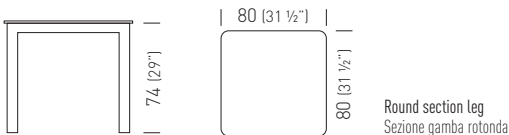

80x80  
160x80

TPARP766.\_\_\_/H74  
TPARP768.\_\_\_/H74



0.27m<sup>3</sup> / 37,70kg / 1pc  
0.30m<sup>3</sup> / 47,40kg / 1pc

€ **1023,00**  
€ **1876,00**

Min. order 10pcs  
each code  
Ordine min 10pz  
per codice

# Profilo

Studio Eurolinea Design

Compactop or Laminated table top  
with painted metal frame. Adjustable feet.

Tavolo con struttura in metallo verniciato,  
piano in Compactop o Laminato. Piedini regolabili



Frame Color / Colore Struttura



00

Compactop Color / Colore Piano Compactop



00



10



14

Laminated Top Color / Colore Piano Laminato



00



10



F



W



RN

Special Finishes / Finiture Speciali

**Compactop:** Special Compactop Surfaces Fullcolor (p. 377) available on demand (min. 5pcs each code).

Special Compactop Surfaces Fullcolor (p. 377) disponibile su richiesta (min. 5pcs per codice).

Special Compactop Surfaces 10 (p. 378) available on demand (min. 20pcs each code).

Special Compactop Surfaces 10 (p. 378) disponibile su richiesta (min. 20pcs per codice).

**Laminated:** Special Laminated Surfaces Wood Effect 25 (p. 383) available on demand (min. 20pcs each code).

Special Laminated Surfaces Wood Effect 25 (p.383) disponibile su richiesta (min. 20pcs per codice).

Special Laminated Surfaces Fenix 25 (p. 384) available on demand (min. 20pcs each code).

Special Laminated Surfaces Fenix 25 (p. 384) disponibile su richiesta (min. 20pcs per codice).

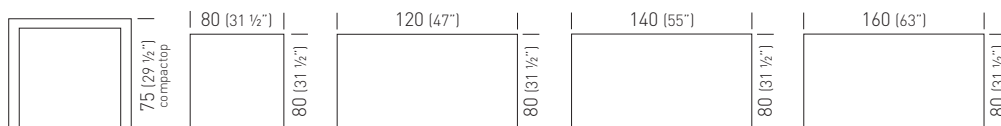

80x80compactop	TPROC500.___/H75		0.32m <sup>3</sup> / 24kg / 1pcs	€	<b>563,00</b>
80x80laminated	TPROL518.___/H75		0.32m <sup>3</sup> / 24kg / 1pcs	€	<b>470,00</b>
80x120compactop	TPROC502.___/H75		0.43m <sup>3</sup> / 29kg / 1pcs	€	<b>787,00</b>
80x120laminated	TPROL520.___/H75		0.43m <sup>3</sup> / 29kg / 1pcs	€	<b>561,00</b>
80x140compactop	TPROC504.___/H75		0.48m <sup>3</sup> / 33kg / 1pcs	€	<b>823,00</b>
80x140laminated	TPROL522.___/H75		0.48m <sup>3</sup> / 33kg / 1pcs	€	<b>614,00</b>
80x160compactop	TPROC506.___/H75		0.53m <sup>3</sup> / 38kg / 1pcs	€	<b>866,00</b>
80x160laminated	TPROL524.___/H75		0.53m <sup>3</sup> / 38kg / 1pcs	€	<b>662,00</b>

# Roller

Studio Eurolinea Design

Tables, chairs, benches and stools Collection.  
 Compactop with technopolymer bases.  
 Available illuminated and suitable for outdoor use.  
 Collezione di tavoli, sedute, panche e sgabelli.  
 I tavoli sono realizzati con piano Compactop  
 e struttura in tecnopolimero.  
 Disponibili con versione luminosa  
 e adatti anche all'uso esterno.



Technopolymer Base Color / Colore Base Tecnopolimero

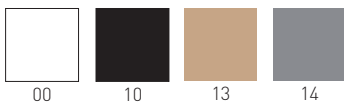

Compactop Color / Colore Piano Compactop

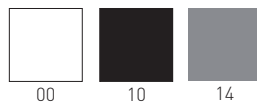

Special Finishes / Finiture Speciali

**Compactop:** Special Compactop Surfaces Fullcolor (p.377) white available on demand (min. 5pcs each code).  
 Special Compactop Surfaces Fullcolor (p.377) bianco disponibile su richiesta (min. 5pcs per codice).

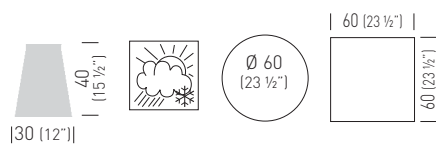

base	BROLLER._._/H40		0.11m <sup>3</sup> / 2,5kg / 1pcs	€	<b>133,00</b>
diam.60	TROLC040._._/H40		0.18m <sup>3</sup> / 8kg / 1pcs	€	<b>330,00</b>
60x60	TROLC044._._/H40		0.18m <sup>3</sup> / 11,8kg / 1pcs	€	<b>291,00</b>



Technopolymer Base Color / Colore Base Tecnopolimero

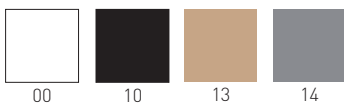

tavolino	244.--/A		0.1m <sup>3</sup> / 4kg / 1pcs	€	<b>172,00</b>
----------	----------	--	--------------------------------	---	---------------



# Roller

Studio Eurolinea Design



230V – 50Hz  
1 X 16W – Led Modul  
IP 65

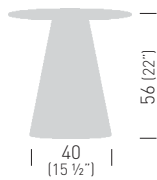

Technopolymer Base Color / Colore Base Tecnopolimero

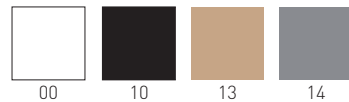

Led version with white transparent base.  
Versione led con base in bianco trasparente.

Compactop Color / Colore Piano Compactop

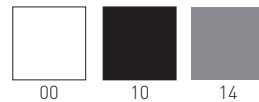

Special Finishes / Finiture Speciali

**Compactop:** Special Compactop Surfaces Fullcolor (p.377)  
white available on demand (min. 5pcs each code).  
Special Compactop Surfaces Fullcolor (p.377)  
bianco disponibile su richiesta (min. 5pcs per codice).

base55	BROLLER.___/H55		0.13m <sup>3</sup> / 9.8kg / 1pcs	€	<b>153,00</b>
base55 Led	BROLLER.___/H55L		0.13m <sup>3</sup> / 13kg / 1pcs	€	<b>493,00</b>



diam.60	TROLC040.___/H55		0.21m <sup>3</sup> / 15.5kg / 1pcs	€	<b>352,00</b>
diam.60 Led	TROLC040.___/H55L		0.21m <sup>3</sup> / 18.8kg / 1pcs	€	<b>691,00</b>



diam.68	TROLC048.___/H55		0.23m <sup>3</sup> / 19kg / 1pcs	€	<b>391,00</b>
diam.68 Led	TROLC048.___/H55L		0.23m <sup>3</sup> / 22.2kg / 1pcs	€	<b>730,00</b>

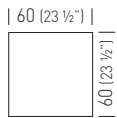

60x60	TROLC044.___/H55		0.21m <sup>3</sup> / 17.5kg / 1pcs	€	<b>312,00</b>
60x60 Led	TROLC044.___/H55L		0.21m <sup>3</sup> / 20.7kg / 1pcs	€	<b>651,00</b>

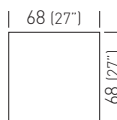

68x68	TROLC052.___/H55		0.23m <sup>3</sup> / 20.5kg / 1pcs	€	<b>336,00</b>
68x68 Led	TROLC052.___/H55L		0.23m <sup>3</sup> / 23.7kg / 1pcs	€	<b>674,00</b>

# Roller

Studio Eurolinea Design

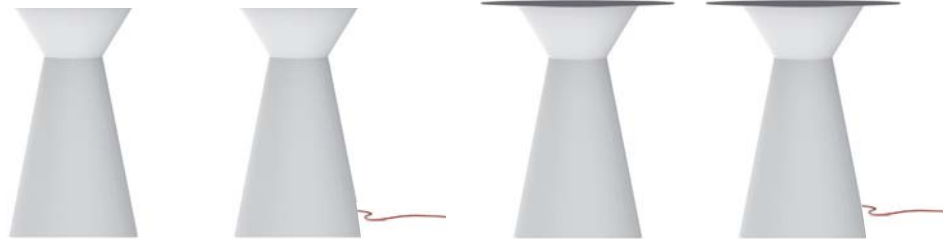

230V - 50Hz  
1 X 16W - Led Modul  
IP 65

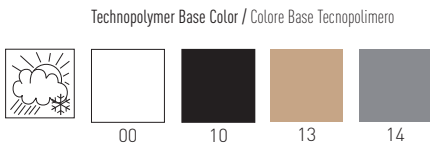
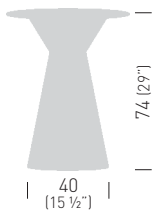

Technopolymer Base Color / Colore Base Tecnopolimero

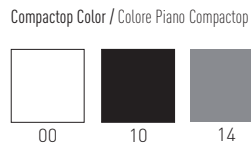

Compactop Color / Colore Piano Compactop

Special Finishes / Finiture Speciali

**Compactop:** Special Compactop Surfaces Fullcolor (p.377)  
white available on demand (min. 5pcs each code).  
Special Compactop Surfaces Fullcolor (p.377)  
bianco disponibile su richiesta (min. 5pcs per codice).

Led version with white transparent base.  
Versione led con base in bianco trasparente.

base74	BROLLER.__/H74		0.13m <sup>3</sup> / 11.30kg / 1pcs	€	<b>192,00</b>
base74+20	BROLLER.__/H74+20		0.13m <sup>3</sup> / 31.30kg / 1pcs	€	<b>233,00</b>
base74 Led	BROLLER.__/H74L		0.13m <sup>3</sup> / 14.45kg / 1pcs	€	<b>532,00</b>



diam.60	TROLC040.___/H74		0.21m <sup>3</sup> / 16.8kg / 1pcs	€	<b>391,00</b>
diam.60 Led	TROLC040.___/H74L		0.21m <sup>3</sup> / 19.9kg / 1pcs	€	<b>730,00</b>



diam.68	TROLC048.___/H74		0.23m <sup>3</sup> / 20.3kg / 1pcs	€	<b>429,00</b>
diam.68 Led	TROLC048.___/H74L		0.23m <sup>3</sup> / 23.4kg / 1pcs	€	<b>769,00</b>



diam.80	TROLC056.___/H74		0.5m <sup>3</sup> / 22.3kg / 1pcs	€	<b>470,00</b>
diam.80 Led	TROLC056.___/H74L		0.5m <sup>3</sup> / 25.5kg / 1pcs	€	<b>808,00</b>

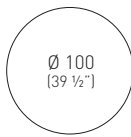

diam.100	TROLC068.___/H74		0.67m <sup>3</sup> / 27kg / 1pcs	€	<b>606,00</b>
diam.100 Led	TROLC068.___/H74L		0.67m <sup>3</sup> / 30kg / 1pcs	€	<b>944,00</b>

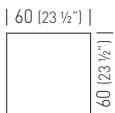

60x60	TROLC044.___/H74		0.21m <sup>3</sup> / 19.5kg / 1pcs	€	<b>352,00</b>
60x60 Led	TROLC044.___/H74L		0.21m <sup>3</sup> / 22.5kg / 1pcs	€	<b>691,00</b>

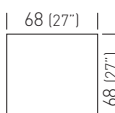

68x68	TROLC052.___/H74		0.23m <sup>3</sup> / 21.8kg / 1pcs	€	<b>375,00</b>
68x68 Led	TROLC052.___/H74L		0.23m <sup>3</sup> / 25kg / 1pcs	€	<b>715,00</b>

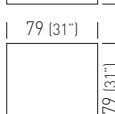

79x79	TROLC060.___/H74		0.50m <sup>3</sup> / 23.8kg / 1pcs	€	<b>398,00</b>
79x79 Led	TROLC060.___/H74L		0.50m <sup>3</sup> / 27kg / 1pcs	€	<b>738,00</b>

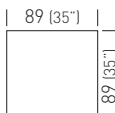

89x89	TROLC064.___/H74		0.60m <sup>3</sup> / 24.8kg / 1pcs	€	<b>512,00</b>
89x89 Led	TROLC064.___/H74L		0.60m <sup>3</sup> / 27.9kg / 1pcs	€	<b>851,00</b>

# Roller

Studio Eurolinea Design



230V – 50Hz  
1 X 16W – Led Modul  
IP 65

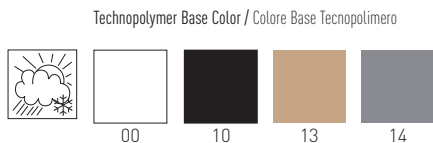
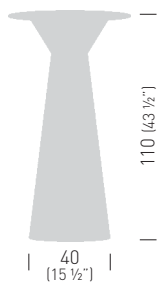

Technopolymer Base Color / Colore Base Tecnopolimero

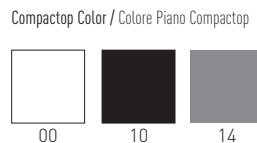

Compactop Color / Colore Piano Compactop

Special Finishes / Finiture Speciali

**Compactop:** Special Compactop Surfaces Fullcolor (p.377)  
white available on demand (min. 5pcs each code).  
Special Compactop Surfaces Fullcolor (p.377)  
bianco disponibile su richiesta (min. 5pcs per codice).

Led version with white transparent base.  
Versione led con base in bianco trasparente.

base110	BROLLER.___/H110		0.2m <sup>3</sup> / 11.30kg / 1pcs	€	<b>291,00</b>
base110+20	BROLLER.___/H110+20		0.2m <sup>3</sup> / 31.30kg / 1pcs	€	<b>330,00</b>
base110 Led	BROLLER.___/H110L		0.2m <sup>3</sup> / 14.45kg / 1pcs	€	<b>631,00</b>

Ø 60 (23 1/2")	diam.60	TROLC040.___/H110		0.28m <sup>3</sup> / 20.6kg / 1pcs	€	<b>488,00</b>
	diam.60 Led	TROLC040.___/H110L		0.28m <sup>3</sup> / 23.8kg / 1pcs	€	<b>823,00</b>

Ø 68 (27")	diam.68	TROLC048.___/H110		0.31m <sup>3</sup> / 24.1kg / 1pcs	€	<b>527,00</b>
	diam.68 Led	TROLC048.___/H110L		0.31m <sup>3</sup> / 27.3kg / 1pcs	€	<b>862,00</b>

Ø 80 (31 1/2")	diam.80	TROLC056.___/H110		0.5m <sup>3</sup> / 26.1kg / 1pcs	€	<b>566,00</b>
	diam.80 Led	TROLC056.___/H110L		0.5m <sup>3</sup> / 29.3kg / 1pcs	€	<b>901,00</b>

60 (23 1/2")	60x60	TROLC044.___/H110		0.28m <sup>3</sup> / 22.8kg / 1pcs	€	<b>448,00</b>
	60x60 Led	TROLC044.___/H110L		0.28m <sup>3</sup> / 26kg / 1pcs	€	<b>787,00</b>

68 (27")	68x68	TROLC052.___/H110		0.31m <sup>3</sup> / 25.6kg / 1pcs	€	<b>473,00</b>
	68x68 Led	TROLC052.___/H110L		0.31m <sup>3</sup> / 28.8kg / 1pcs	€	<b>811,00</b>

79 (31")	79x79	TROLC060.___/H110		0.5m <sup>3</sup> / 27.6kg / 1pcs	€	<b>499,00</b>
	79x79 Led	TROLC060.___/H110L		0.5m <sup>3</sup> / 30.8kg / 1pcs	€	<b>839,00</b>

# Roller

Studio Eurolinea Design

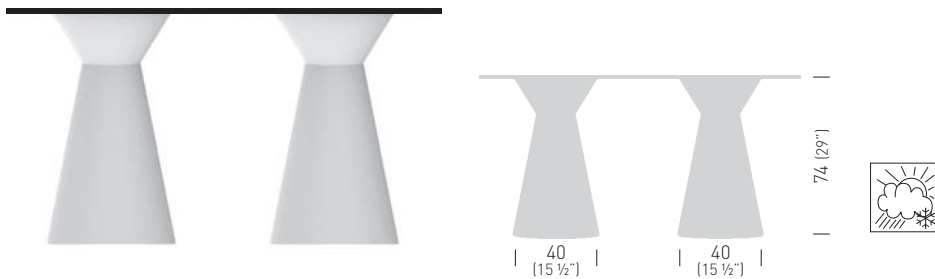

230V – 50Hz  
1 X 16W – Led Modul  
IP 65

## Technopolymer Base Color / Colore Base Tecnopolimero

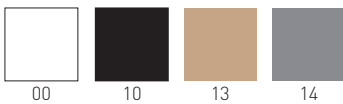

Led version with white transparent base.  
Versione led con base in bianco trasparente.

## Compactop Color / Colore Piano Compactop

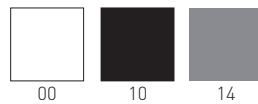

## Special Finishes / Finiture Speciali

**Compactop:** Special Compactop Surfaces Fullcolor (p.377) white available on demand (min. 5pcs each code).  
Special Compactop Surfaces Fullcolor (p.377) bianco disponibile su richiesta (min. 5pcs per codice).

	base74	BROLLER.__/2H74	0.26m <sup>3</sup> / 22.60kg / 1pcs	€ <b>388,00</b>
	120x50	TROLC072._._/2H74	0.56m <sup>3</sup> / 38.1kg / 1pcs	€ <b>777,00</b>
	120x80	TROLC076._._/2H74	0.56m <sup>3</sup> / 39.1kg / 1pcs	€ <b>781,00</b>
	140x70	TROLC080._._/2H74	0.66m <sup>3</sup> / 42.6kg / 1pcs	€ <b>789,00</b>
	159x79	TROLC084._._/2H74	0.94m <sup>3</sup> / 45.6kg / 1pcs	€ <b>835,00</b>
	base110	BROLLER.__/2H110	0.38m <sup>3</sup> / 30.2kg / 1pcs	€ <b>583,00</b>
	120x50	TROLC072._._/H110	0.66m <sup>3</sup> / 45.7kg / 1pcs	€ <b>972,00</b>
	120x80	TROLC076._._/H110	0.66m <sup>3</sup> / 46.7kg / 1pcs	€ <b>977,00</b>
	140x70	TROLC080._._/H110	0.84m <sup>3</sup> / 50.2kg / 1pcs	€ <b>987,00</b>
	159x79	TROLC084._._/H110	1.04m <sup>3</sup> / 53.2kg / 1pcs	€ <b>1032,00</b>



# Saturno

Studio Eurolinea Design

Compactop with painted aluminum frame.

Tavolo con piano Compactop e struttura in alluminio verniciato.



Base Color / Colore Base



00

Top Color / Colore Piano



00



10



14

Special Finishes / Finiture Speciali

**Compactop:** Special Compactop Surfaces Fullcolor (p. 377) available on demand (min. 5pcs each code).  
Special Compactop Surfaces Fullcolor (p. 377) disponibile su richiesta (min. 5pcs per codice).  
Special Compactop Surfaces 10 (p. 378) available on demand (min. 20pcs each code).  
Special Compactop Surfaces 10 (p. 378) disponibile su richiesta (min. 20pcs per codice).

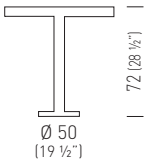

Ø 80  
(31 1/2")

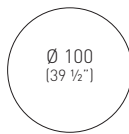

Ø 100  
(39 1/2")

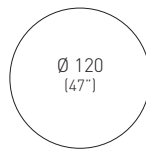

Ø 120  
(47")

diam.80  
diam.100  
diam.120

TSATC142.\_\_\_/H72  
TSATC146.\_\_\_/H72  
TSATC150.\_\_\_/H72



0.56m<sup>3</sup> / 28kg / 1pcs  
0.74m<sup>3</sup> / 30kg / 1pcs  
0.87m<sup>3</sup> / 33kg / 1pcs

€ **1240,00**  
€ **1449,00**  
€ **1688,00**

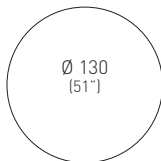
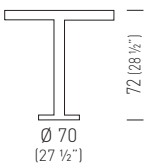

Ø 130  
(51")

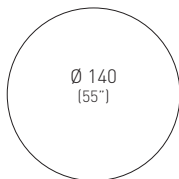

Ø 140  
(55")

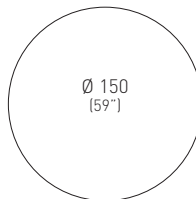

Ø 150  
(59")

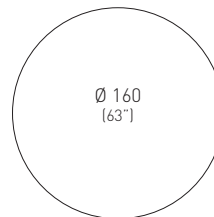

Ø 160  
(63")

diam.130  
diam.140  
diam.150  
diam.160

TSATC153.\_\_\_/H72  
TSATC156.\_\_\_/H72  
TSATC159.\_\_\_/H72  
TSATC162.\_\_\_/H72



0.90m<sup>3</sup> / 50kg / 1pcs  
0.90m<sup>3</sup> / 53kg / 1pcs  
0.90m<sup>3</sup> / 56kg / 1pcs  
1.10m<sup>3</sup> / 59kg / 1pcs

€ **1872,00**  
€ **2009,00**  
€ **2266,00**  
€ **2660,00**

# Saturnino

Studio Eurolinea Design



Waiting areas and Coffee Table,  
Compactop with painted aluminum frame.  
Tavolino attesa con piano Compactop  
e struttura in alluminio verniciato.

Base Color / Colore Base



00

Top Color / Colore Piano



00  
Fullcolor

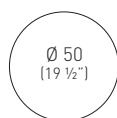
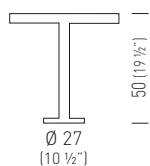

diam.50

TSATC140.\_.\_/H50

 0.3m<sup>3</sup> / 10kg / 1pcs

€ **618,00**

# Simply

Studio Eurolinea Design

Stackable table with laminated or Iron top and painted metal frame.

Tavolo impilabile con piano in laminato o Iron e telaio in metallo verniciato.



Only Iron Top  
Solo Iron top



Frame Color / Colore Struttura

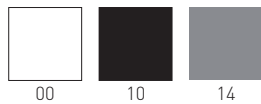

Iron Top Color / Colore Piano Iron

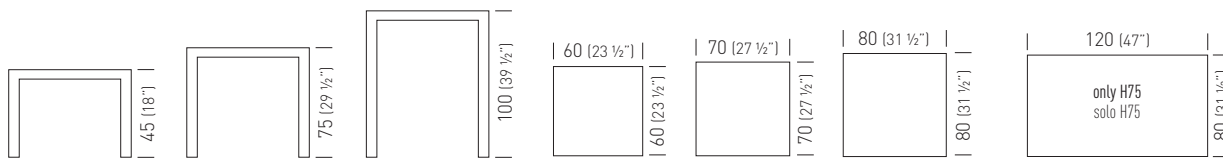
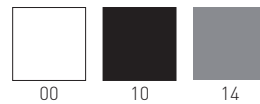

60x60	TSIMI430._._/H45		0.28m³ / 17.0kg / 1pcs	€	<b>375,00</b>
60x60	TSIMI430._._/H75		0.28m³ / 17.5kg / 1pcs	€	<b>375,00</b>
60x60	TSIMI430._._/H100		0.28m³ / 18.5kg / 1pcs	€	<b>423,00</b>
70x70	TSIMI432._._/H45		0.28m³ / 18.0kg / 1pcs	€	<b>388,00</b>
70x70	TSIMI432._._/H75		0.28m³ / 18.5kg / 1pcs	€	<b>388,00</b>
70x70	TSIMI432._._/H100		0.28m³ / 19.5kg / 1pcs	€	<b>431,00</b>
80x80	TSIMI434._._/H45		0.40m³ / 19.0kg / 1pcs	€	<b>408,00</b>
80x80	TSIMI434._._/H75		0.40m³ / 19.5kg / 1pcs	€	<b>408,00</b>
80x80	TSIMI434._._/H100		0.40m³ / 20.5kg / 1pcs	€	<b>453,00</b>
120x80	TSIMI436._._/H75		0.40m³ / 25.0kg / 1pcs	€	<b>567,00</b>

Frame Color / Colore Struttura

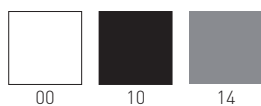

Laminated Top Color / Colore Piano Laminato



Special Finishes / Finiture Speciali

**Laminated:** Special Laminated Surfaces Wood Effect 25 (p. 383) available on demand (min. 20pcs each code).  
Special Laminated Surfaces Wood Effect 25 (p.383) disponibile su richiesta (min. 20pcs per codice).  
Special Laminated Surfaces Fenix 25 (p. 384) available on demand (min. 20pcs each code).  
Special Laminated Surfaces Fenix 25 (p. 384) disponibile su richiesta (min. 20pcs per codice).

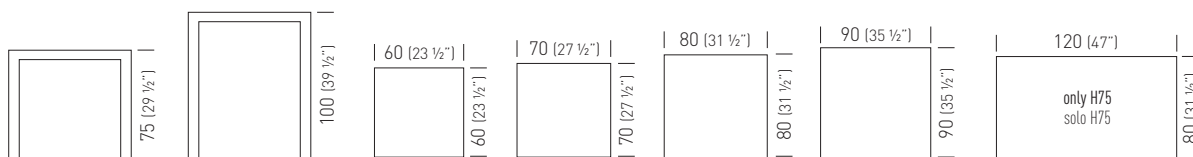

60x60	TSIML438._._/H75		0.28m³ / 16kg / 1pcs	€	<b>704,00</b>
60x60	TSIML438._._/H100		0.28m³ / 17kg / 1pcs	€	<b>704,00</b>
70x70	TSIML440._._/H75		0.28m³ / 17kg / 1pcs	€	<b>296,00</b>
70x70	TSIML440._._/H100		0.28m³ / 18kg / 1pcs	€	<b>336,00</b>
80x80	TSIML442._._/H75		0.40m³ / 18.5kg / 1pcs	€	<b>310,00</b>
80x80	TSIML442._._/H100		0.40m³ / 19.5kg / 1pcs	€	<b>374,00</b>
90x90	TSIML444._._/H75		0.40m³ / 21kg / 1pcs	€	<b>336,00</b>
90x90	TSIML444._._/H100		0.40m³ / 22kg / 1pcs	€	<b>375,00</b>
120x80	TSIML446._._/H75		0.40m³ / 23.5kg / 1pcs	€	<b>454,00</b>

# Space

Studio Eurolinea Design



Innovative and durable, the Space table is characterized by a thin Compactop profile and a solid four-legged structure in anodized aluminum. Resistant to stains, abrasions and thermal variations, the table can also be used for intensive use.

Innovativo e durevole, il tavolo Space è caratterizzato da un piano in Compactop dal profilo sottile e da una solida struttura a quattro gambe in alluminio anodizzato. Resistente alle macchie, alle abrasioni e alle variazioni termiche, il tavolo può essere utilizzato anche per utilizzi intensivi.

Frame Color / Colore Struttura



Anodized aluminum  
Alluminio anodizzato

Compactop Color / Colore Piano Compactop



00



10



14

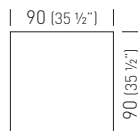
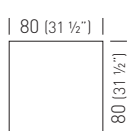

80x80  
90x90

TSPAC410.\_\_-/H75  
TSPAC412.\_\_-/H75



0.36m<sup>3</sup> / 19kg / 1pcs  
0.36m<sup>3</sup> / 21kg / 1pcs

€ **791,00**  
€ **854,00**

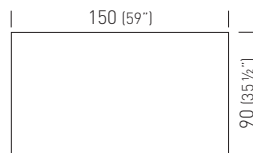
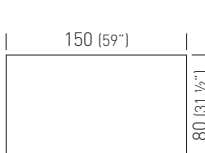
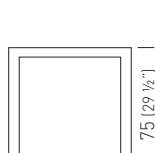

80x150  
90x150

TSPAC414.\_\_-/H75  
TSPAC416.\_\_-/H75



0.68m<sup>3</sup> / 28kg / 1pcs  
0.68m<sup>3</sup> / 30kg / 1pcs

€ **967,00**  
€ **1034,00**

# Stefano

Studio Eurolinea Design

Compactop table-top and beech legs.  
Or with technopolymer legs,  
suitable for outdoor use. Lightweight and functional.  
Tavolo con piano Compactop e gambe in legno di faggio.  
Disponibile anche con gambe in tecnopolimero,  
adatte all'uso esterno. Leggero e funzionale.



## Wooden Frame Color / Colore Struttura Legno



## Top Color / Colore Piano

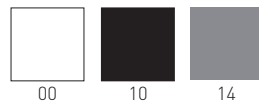

## Special Finishes / Finiture Speciali

**Compactop:** Special Compactop Surfaces 10 (p. 378) available on demand (min. 20pcs each code).  
Special Compactop Surfaces 10 (p. 378) disponibile su richiesta (min. 20pcs per codice).

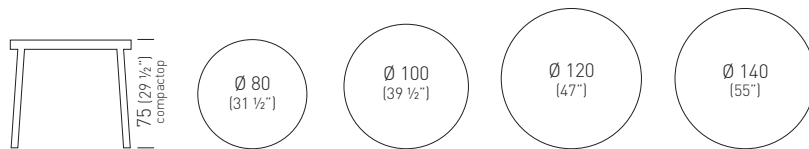

diam.80	TSSTEC102. __-_/H75	0.4m <sup>3</sup> / 18kg / 1pcs	€	493,00
diam.80 fullcolor straight edge / bordo dritto (min 5pcs)	TSSTEC103. __-_/H75	0.4m <sup>3</sup> / 18kg / 1pcs	€	592,00
diam.80 fullcolor inclined edge / bordo inclinato (min 5pcs)	TSSTEC104. __-_/H75	0.4m <sup>3</sup> / 18kg / 1pcs	€	592,00
diam.100	TSSTEC114. __-_/H75	0.58m <sup>3</sup> / 19kg / 1pcs	€	598,00
diam.100 fullcolor straight edge / bordo dritto (min 5pcs)	TSSTEC115. __-_/H75	0.58m <sup>3</sup> / 19kg / 1pcs	€	718,00
diam.100 fullcolor inclined edge / bordo inclinato (min 5pcs)	TSSTEC116. __-_/H75	0.58m <sup>3</sup> / 19kg / 1pcs	€	718,00
diam.120	TSSTEC122. __-_/H75	0.71m <sup>3</sup> / 20kg / 1pcs	€	705,00
diam.120 fullcolor straight edge / bordo dritto (min 5pcs)	TSSTEC123. __-_/H75	0.71m <sup>3</sup> / 20kg / 1pcs	€	846,00
diam.120 fullcolor inclined edge / bordo inclinato (min 5pcs)	TSSTEC124. __-_/H75	0.71m <sup>3</sup> / 20kg / 1pcs	€	846,00
diam.140	TSSTEC129. __-_/H75	0.87m <sup>3</sup> / 24kg / 1pcs	€	784,00
diam.140 fullcolor straight edge / bordo dritto (min 5pcs)	TSSTEC130. __-_/H75	0.87m <sup>3</sup> / 24kg / 1pcs	€	941,00
diam.140 fullcolor inclined edge / bordo inclinato (min 5pcs)	TSSTEC131. __-_/H75	0.87m <sup>3</sup> / 24kg / 1pcs	€	941,00

## Technopolymer Frame Color / Colore Struttura Tecnopolimero

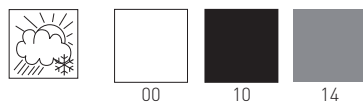

## Top Color / Colore Piano

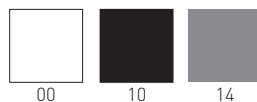

## Special Finishes / Finiture Speciali

**Compactop:** Special Compactop Surfaces 10 (p. 378) available on demand (min. 20pcs each code).  
Special Compactop Surfaces 10 (p. 378) disponibile su richiesta (min. 20pcs per codice).

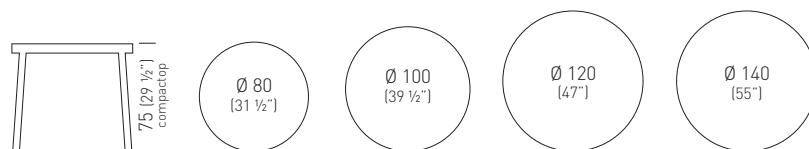

diam.80	TSSTEC102. __-_/H75	0.4m <sup>3</sup> / 18kg / 1pcs	€	493,00
diam.80 fullcolor straight edge / bordo dritto (min 5pcs)	TSSTEC103. __-_/H75	0.4m <sup>3</sup> / 18kg / 1pcs	€	592,00
diam.80 fullcolor inclined edge / bordo inclinato (min 5pcs)	TSSTEC104. __-_/H75	0.4m <sup>3</sup> / 18kg / 1pcs	€	592,00
diam.100	TSSTEC114. __-_/H75	0.58m <sup>3</sup> / 19kg / 1pcs	€	598,00
diam.100 fullcolor straight edge / bordo dritto (min 5pcs)	TSSTEC115. __-_/H75	0.58m <sup>3</sup> / 19kg / 1pcs	€	718,00
diam.100 fullcolor inclined edge / bordo inclinato (min 5pcs)	TSSTEC116. __-_/H75	0.58m <sup>3</sup> / 19kg / 1pcs	€	718,00
diam.120	TSSTEC122. __-_/H75	0.71m <sup>3</sup> / 20kg / 1pcs	€	705,00
diam.120 fullcolor straight edge / bordo dritto (min 5pcs)	TSSTEC123. __-_/H75	0.71m <sup>3</sup> / 20kg / 1pcs	€	846,00
diam.120 fullcolor inclined edge / bordo inclinato (min 5pcs)	TSSTEC124. __-_/H75	0.71m <sup>3</sup> / 20kg / 1pcs	€	846,00
diam.140	TSSTEC129. __-_/H75	0.87m <sup>3</sup> / 24kg / 1pcs	€	784,00
diam.140 fullcolor straight edge / bordo dritto (min 5pcs)	TSSTEC130. __-_/H75	0.87m <sup>3</sup> / 24kg / 1pcs	€	941,00
diam.140 fullcolor inclined edge / bordo inclinato (min 5pcs)	TSSTEC131. __-_/H75	0.87m <sup>3</sup> / 24kg / 1pcs	€	941,00

# Stefano

Studio Eurolinea Design



Compactop table-top and beech legs.  
Or with technopolymer legs,  
suitable for outdoor use. Lightweight and functional.  
Tavolo con piano Compactop e gambe in legno di faggio.  
Disponibile anche con gambe in tecnopolimero,  
adatte all'uso esterno. Leggero e funzionale.

## Wooden Frame Color / Colore Struttura Legno



## Top Color / Colore Piano

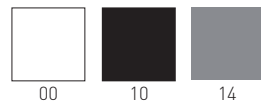

## Special Finishes / Finiture Speciali

**Compactop:** Special Compactop Surfaces 10 (p. 378) available on demand (min. 20pcs each code).  
Special Compactop Surfaces 10 (p. 378) disponibile su richiesta (min. 20pcs per codice).

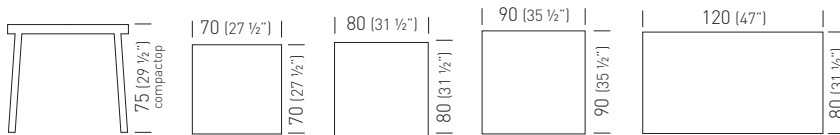

70x70	TSTEC098._._/H75		0.40m <sup>3</sup> / 17kg / 1pcs	€	<b>398,00</b>
70x70 fullcolor straight edge / bordo dritto (min 5pcs)	TSTEC099._._/H75		0.40m <sup>3</sup> / 17kg / 1pcs	€	<b>481,00</b>
70x70 fullcolor inclined edge / bordo inclinato (min 5pcs)	TSTEC100._._/H75		0.40m <sup>3</sup> / 17kg / 1pcs	€	<b>481,00</b>
80x80	TSTEC106._._/H75		0.40m <sup>3</sup> / 18kg / 1pcs	€	<b>428,00</b>
80x80 fullcolor straight edge / bordo dritto (min 5pcs)	TSTEC107._._/H75		0.40m <sup>3</sup> / 18kg / 1pcs	€	<b>513,00</b>
80x80 fullcolor inclined edge / bordo inclinato (min 5pcs)	TSTEC108._._/H75		0.40m <sup>3</sup> / 18kg / 1pcs	€	<b>513,00</b>
90x90	TSTEC110._._/H75		0.40m <sup>3</sup> / 18.5kg / 1pcs	€	<b>507,00</b>
90x90 fullcolor straight edge / bordo dritto (min 5pcs)	TSTEC111._._/H75		0.40m <sup>3</sup> / 18.5kg / 1pcs	€	<b>608,00</b>
90x90 fullcolor inclined edge / bordo inclinato (min 5pcs)	TSTEC112._._/H75		0.40m <sup>3</sup> / 18.5kg / 1pcs	€	<b>608,00</b>
120x80	TSTEC126._._/H75		0.52m <sup>3</sup> / 20kg / 1pcs	€	<b>592,00</b>
120x80 fullcolor straight edge / bordo dritto (min 5pcs)	TSTEC127._._/H75		0.52m <sup>3</sup> / 20kg / 1pcs	€	<b>710,00</b>
120x80 fullcolor inclined edge / bordo inclinato (min 5pcs)	TSTEC128._._/H75		0.52m <sup>3</sup> / 20kg / 1pcs	€	<b>710,00</b>

## Technopolymer Frame Color / Colore Struttura Tecnopolimero

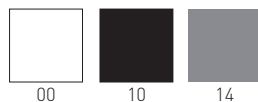

## Top Color / Colore Piano

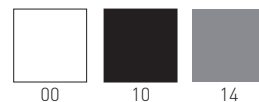

## Special Finishes / Finiture Speciali

**Compactop:** Special Compactop Surfaces 10 (p. 378) available on demand (min. 20pcs each code).  
Special Compactop Surfaces 10 (p. 378) disponibile su richiesta (min. 20pcs per codice).

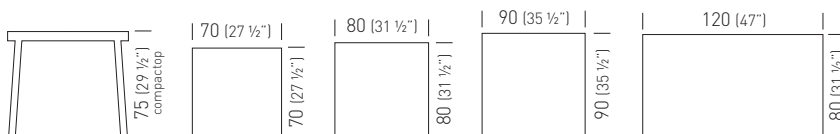

70x70	TSTEC098._._/H75		0.40m <sup>3</sup> / 17kg / 1pcs	€	<b>398,00</b>
70x70 fullcolor straight edge / bordo dritto (min 5pcs)	TSTEC099._._/H75		0.40m <sup>3</sup> / 17kg / 1pcs	€	<b>481,00</b>
70x70 fullcolor inclined edge / bordo inclinato (min 5pcs)	TSTEC100._._/H75		0.40m <sup>3</sup> / 17kg / 1pcs	€	<b>481,00</b>
80x80	TSTEC106._._/H75		0.40m <sup>3</sup> / 18kg / 1pcs	€	<b>428,00</b>
80x80 fullcolor straight edge / bordo dritto (min 5pcs)	TSTEC107._._/H75		0.40m <sup>3</sup> / 18kg / 1pcs	€	<b>513,00</b>
80x80 fullcolor inclined edge / bordo inclinato (min 5pcs)	TSTEC108._._/H75		0.40m <sup>3</sup> / 18kg / 1pcs	€	<b>513,00</b>
90x90	TSTEC110._._/H75		0.40m <sup>3</sup> / 18.5kg / 1pcs	€	<b>507,00</b>
90x90 fullcolor straight edge / bordo dritto (min 5pcs)	TSTEC111._._/H75		0.40m <sup>3</sup> / 18.5kg / 1pcs	€	<b>608,00</b>
90x90 fullcolor inclined edge / bordo inclinato (min 5pcs)	TSTEC112._._/H75		0.40m <sup>3</sup> / 18.5kg / 1pcs	€	<b>608,00</b>
120x80	TSTEC126._._/H75		0.52m <sup>3</sup> / 20kg / 1pcs	€	<b>592,00</b>
120x80 fullcolor straight edge / bordo dritto (min 5pcs)	TSTEC127._._/H75		0.52m <sup>3</sup> / 20kg / 1pcs	€	<b>710,00</b>
120x80 fullcolor inclined edge / bordo inclinato (min 5pcs)	TSTEC128._._/H75		0.52m <sup>3</sup> / 20kg / 1pcs	€	<b>710,00</b>

# Stefano 3-Pod

Studio Eurolinea Design

Waiting areas and Coffee Table,

Compactop with three beech legs.

Tavolino attesa con piano Compactop  
e tre gambe in legno di faggio.



Wooden Frame Color / Colore Struttura Legno



Top Color / Colore Piano



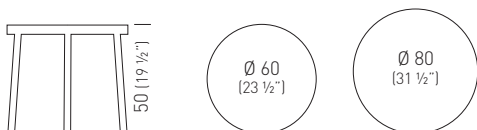

Special Finishes / Finiture Speciali

**Compactop:** Special Compactop Surfaces Fullcolor (p. 377) white available on demand (min. 5pcs each code).  
Special Compactop Surfaces Fullcolor (p. 377) bianco disponibile su richiesta (min. 5pcs per codice).



diam.60  
diam.80

TSTEC090.\_\_\_/3H50  
TSTEC102.\_\_\_/3H50

 0.30m<sup>3</sup> / 17kg / 1pcs  
 0.40m<sup>3</sup> / 18kg / 1pcs

€ **394,00**  
€ **454,00**

# Stefanino

Studio Eurolinea Design

Waiting areas and Coffee Table,  
Compactop with beech legs.  
Tavolino attesa con piano Compactop  
e gambe in legno di faggio.



Wooden Frame Color / Colore Struttura Legno



F

Top Color / Colore Piano



00



10



14

Fullcolor

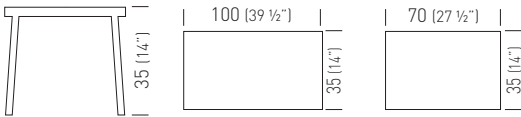

100x35  
70x35

TSTEC118.\_.\_/H35  
TSTEC094.\_.\_/H35



0.34m<sup>3</sup> / 10kg / 1pcs



**316,00**



0.34m<sup>3</sup> / 7kg / 1pcs



**296,00**



# Step

Studio Eurolinea Design

High table, co-injected metal frame with techno polymer, Compactop. Suitable for outdoor purpose.

Tavolo alto con struttura in metallo sovrastampato con tecnopolimero, piano in Compactop. Adatto anche all'uso esterno.



Technopolymer Frame Color / Colore Struttura Tecnopolimero

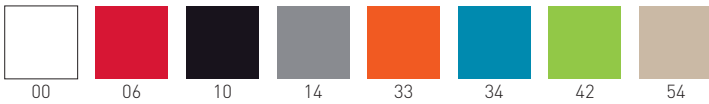

Compactop Color / Colore Piano Compactop

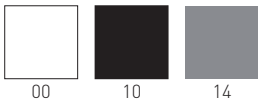

Special Finishes / Finiture Speciali

**Compactop:** Special Compactop Surfaces 10 (p. 378) available on demand (min. 20pcs each code).  
Special Compactop Surfaces 10 (p. 378) disponibile su richiesta (min. 20pcs per codice).

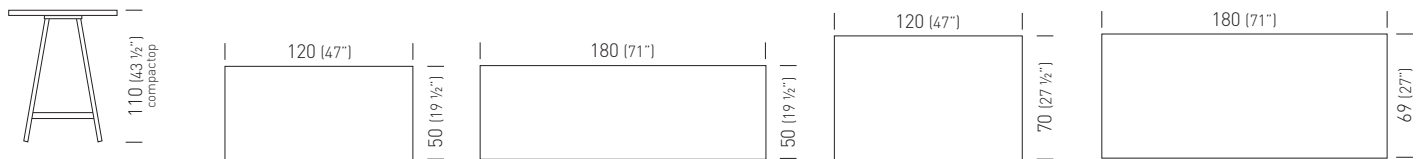

120x50	TSTPC820._._/H110		0.47m <sup>3</sup> / 35kg / 1pcs	€	<b>680,00</b>
120x50fullcolor (min 5pcs)	TSTPC821.00._./H110		0.47m <sup>3</sup> / 35kg / 1pcs	€	<b>749,00</b>
120x70	TSTPC822._._/H110		0.48m <sup>3</sup> / 36kg / 1pcs	€	<b>715,00</b>
120x70fullcolor (min 5pcs)	TSTPC823.00._./H110		0.48m <sup>3</sup> / 36kg / 1pcs	€	<b>856,00</b>
180x50	TSTPC824._._/H110		0.60m <sup>3</sup> / 42kg / 1pcs	€	<b>704,00</b>
180x50fullcolor (min 5pcs)	TSTPC825.00._./H110		0.60m <sup>3</sup> / 42kg / 1pcs	€	<b>845,00</b>
180x69	TSTPC826._._/H110		0.60m <sup>3</sup> / 43kg / 1pcs	€	<b>736,00</b>
180x69fullcolor (min 5pcs)	TSTPC827.00._./H110		0.60m <sup>3</sup> / 43kg / 1pcs	€	<b>884,00</b>



# Surfy 2027 Tables & Desks



Table collection, meeting tables and modular desks, part of the "2027" system, suitable for completing hospitality and office settings with integrated design. The tables are made with painted metal structures and Laminate or Compactop table-tops, available with metal fairlead solutions.

Collezione tavoli, tavoli meeting e scrivanie modulari, parte del sistema "2027", adatti a completare con lo stesso design progetti integrati di ospitalità ed ufficio. I tavoli sono realizzati con strutture in metallo verniciato e piani in Laminate o Compactop, disponibili con soluzioni passacavi in metallo. Strutture di sostegno con forma a cavalletto per essere snelle e resistenti, oltre che colorate a tutto tondo.

## Finishings / Finiture

### Frame colors / Colori struttura



00

10

16

21

22

35

55

### Laminated top color / Colori piano laminato

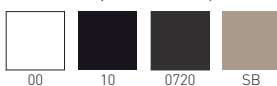

00

10

0720

Fenix

SB

## SURFY HUB 2027 ROUND



### Frame colors / Colori struttura

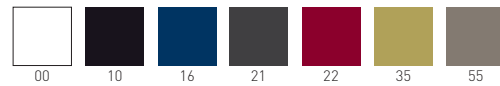

### Laminated Top Color / Colore Piano Laminato

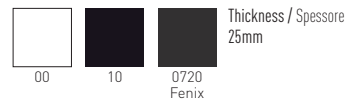

diam. 120laminated	TSRHL260._-_/H74	0.71m <sup>3</sup> / 30kg / 1pcs	€ <b>777,00</b>
diam. 120lam.fenix	TSRHL260.0720-_/H74	0.71m <sup>3</sup> / 30kg / 1pcs	€ <b>1017,00</b>
diam. 140laminated	TSRHL262._-_/H74	0.90m <sup>3</sup> / 37kg / 1pcs	€ <b>1012,00</b>
diam. 140lam.fenix	TSRHL262.0720-_/H74	0.90m <sup>3</sup> / 37kg / 1pcs	€ <b>1407,00</b>
diam. 160laminated	TSRHL264._-_/H74	1.1m <sup>3</sup> / 43kg / 1pcs	€ <b>1744,00</b>
diam. 160lam.fenix	TSRHL264.0720-_/H74	1.1m <sup>3</sup> / 43kg / 1pcs	€ <b>2438,00</b>

## SURFY HUB 2027 SQUARE



### Frame colors / Colori struttura



### Laminated Top Color / Colore Piano Laminato

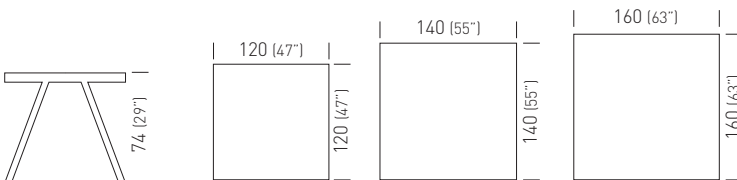
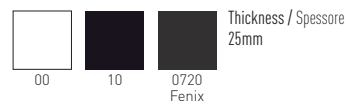

120x120laminated	TSRHL261._-_/H74	0.71m <sup>3</sup> / 34kg / 1pcs	€ <b>777,00</b>
120x120lam.fenix	TSRHL261.0720-_/H74	0.71m <sup>3</sup> / 34kg / 1pcs	€ <b>1017,00</b>
140x140laminated	TSRHL263._-_/H74	0.90m <sup>3</sup> / 41kg / 1pcs	€ <b>1012,00</b>
140x140lam.fenix	TSRHL263.0720-_/H74	0.90m <sup>3</sup> / 41kg / 1pcs	€ <b>1407,00</b>
160x160laminated	TSRHL265._-_/H74	1.1m <sup>3</sup> / 50kg / 1pcs	€ <b>1744,00</b>
160x160lam.fenix	TSRHL265.0720-_/H74	1.1m <sup>3</sup> / 50kg / 1pcs	€ <b>2438,00</b>

## SURFY OUTDOOR 2027 ROUND



### Frame colors / Colori struttura

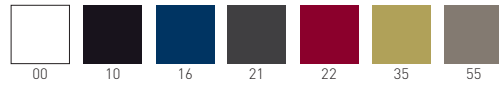

### Laminated Top Color / Colore Piano Laminato

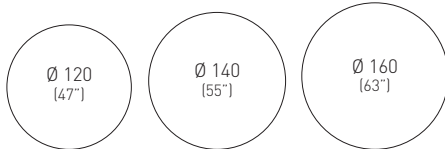
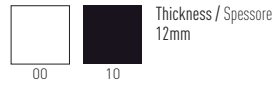

diam. 120Compactop  
diam. 140Compactop  
diam. 160Compactop

TSROC280.\_-\_/H73  
TSROC286.\_-\_/H73  
TSROC292.\_-\_/H73

0.71m<sup>3</sup> / 35kg / 1pcs  
0.90m<sup>3</sup> / 41kg / 1pcs  
1.1m<sup>3</sup> / 49kg / 1pcs

€ **956,00**  
€ **1361,00**  
€ **2195,00**

## SURFY OUTDOOR 2027 SQUARE



### Frame colors / Colori struttura



### Laminated Top Color / Colore Piano Laminato

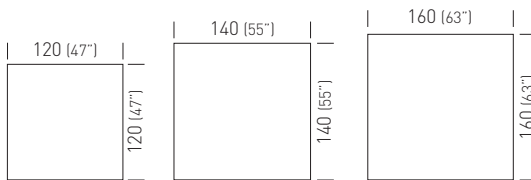
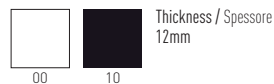

120x120Compactop  
140x140Compactop  
160x160Compactop

TSROC283.\_-\_/H73  
TSROC289.\_-\_/H73  
TSROC295.\_-\_/H73

0.71m<sup>3</sup> / 39kg / 1pcs  
0.90m<sup>3</sup> / 49kg / 1pcs  
1.1m<sup>3</sup> / 59kg / 1pcs

€ **956,00**  
€ **1361,00**  
€ **2195,00**

## SURFY HUB 2027 OVAL



### Frame colors / Colori struttura

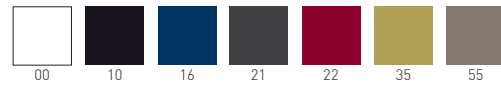

### Laminated Top Color / Colore Piano Laminato

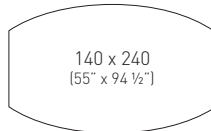
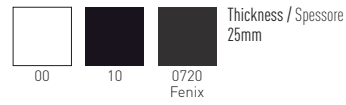

140x240laminated  
140x240lam.fenix

TSRHL275.\_-\_/H74  
TSRHL275.0720-\_/H74

1.50m³ / 74kg / 1pcs  
 1.50m³ / 74kg / 1pcs

€ **2626,00**  
€ **3001,00**



**Option:** Cod. ACCV030.\_\_  
Metal Fairlead Solution  
Tubo metallico passacavi  
**€ 74,00**

### Colors / Colori

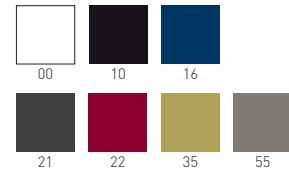

## SURFY HUB 2027 RECTANGLE



### Frame colors / Colori struttura



### Laminated Top Color / Colore Piano Laminato

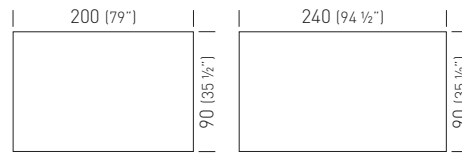
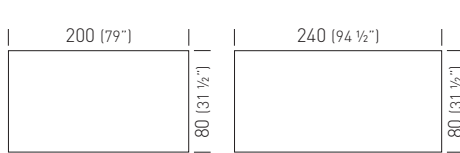
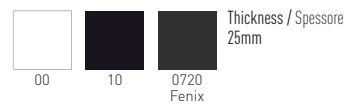

80x200laminated  
80x200lam.fenix  
80x240laminated  
80x240lam.fenix  
90x200laminated  
90x200lam.fenix  
90x240laminated  
90x240lam.fenix

TSRHL266.\_-\_/H74  
TSRHL266.0720-\_/H74  
TSRHL267.\_-\_/H74  
TSRHL267.0720-\_/H74  
TSRHL268.\_-\_/H74  
TSRHL268.0720-\_/H74  
TSRHL269.\_-\_/H74  
TSRHL269.0720-\_/H74

0.76m³ / 41kg / 1pcs  
 0.76m³ / 41kg / 1pcs  
 0.90m³ / 46kg / 1pcs  
 0.90m³ / 46kg / 1pcs  
 0.90m³ / 44kg / 1pcs  
 0.90m³ / 44kg / 1pcs  
 1.0m³ / 51kg / 1pcs  
 1.0m³ / 51kg / 1pcs

€ **1088,00**  
€ **1294,00**  
€ **1220,00**  
€ **1482,00**  
€ **1200,00**  
€ **1426,00**  
€ **1369,00**  
€ **1651,00**



**Option:** Cod. ACCV030.\_\_  
Metal Fairlead Solution  
Tubo metallico passacavi  
**€ 74,00**

### Colors / Colori

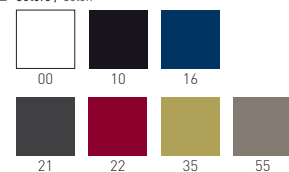

# SURFY HUB 2027 RECTANGLE



## Frame colors / Colori struttura

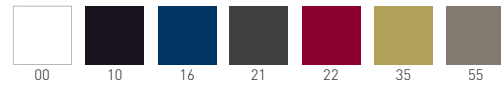

## Laminated Top Color / Colore Piano Laminato

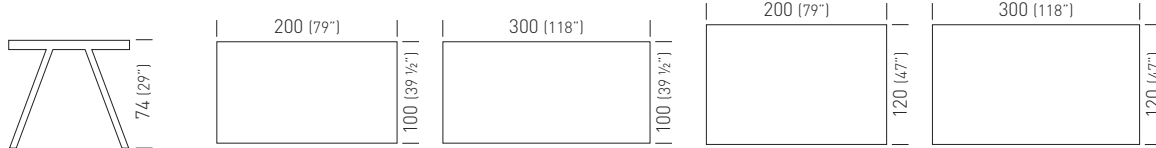
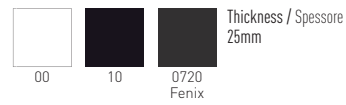

100x200laminated  
100x200lam.fenix  
100x300laminated  
100x300lam.fenix  
120x200laminated  
120x200lam.fenix  
120x300laminated  
120x300lam.fenix

TSRHL270.\_\_-\_/H74  
TSRHL270.0720-\_/H74  
TSRHL271.\_\_-\_/H74  
TSRHL271.0720-\_/H74  
TSRHL272.\_\_-\_/H74  
TSRHL272.0720-\_/H74  
TSRHL273.\_\_-\_/H74  
TSRHL273.0720-\_/H74

0.92m³ / 45kg / 1pcs  
0.92m³ / 45kg / 1pcs  
1.4m³ / 65kg / 1pcs  
1.4m³ / 65kg / 1pcs  
1.1m³ / 52kg / 1pcs  
1.1m³ / 52kg / 1pcs  
1.6m³ / 74kg / 1pcs  
1.6m³ / 74kg / 1pcs

€ **1181,00**  
€ **1407,00**  
€ **2063,00**  
€ **2438,00**  
€ **1294,00**  
€ **1538,00**  
€ **2364,00**  
€ **2739,00**



**Option:** Cod. ACCV030-\_\_  
Metal Fairlead Solution  
Tubo metallico passacavi  
**€ 74,00**

## Colors / Colori

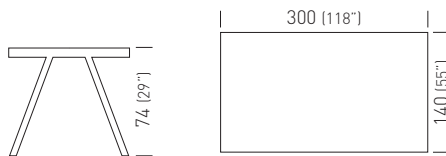
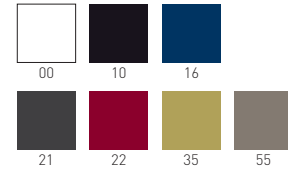

140x300laminated  
140x300lam.fenix

TSRHL276.\_\_-\_/H74  
TSRHL276.0720-\_/H74

1.9m³ / 81kg / 1pcs  
1.9m³ / 81kg / 1pcs

€ **2739,00**  
€ **3188,00**



**Option:** Cod. ACCV030-\_\_  
Metal Fairlead Solution  
Tubo metallico passacavi  
**€ 74,00**

## Colors / Colori

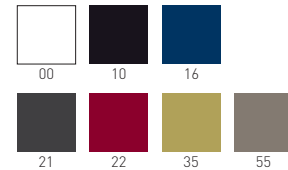

# SURFY DESK 2027

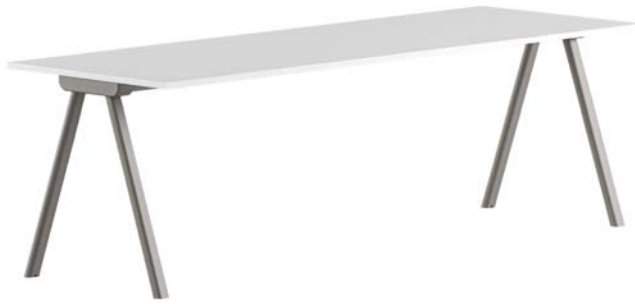

## Frame colors / Colori struttura

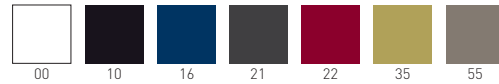

**Option:** Cod. 1101  
Cable Routing Option,  
anodized Aluminum 8x8 cm,  
black brush  
Opzione Passacavi,  
Alluminio anodizzato 8x8 cm  
spazzolina nera  
**€ 124,00**

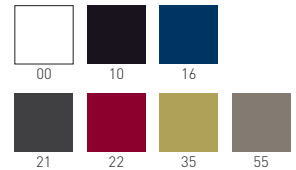

**Option:** Cod. ACCV030...  
Metal Fairlead Solution  
Tubo metallico passacavi  
**€ 74,00**

Colors / Colori

## Laminated Top Color / Colore Piano Laminato

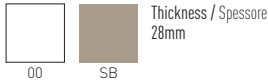

Thickness / Spessore  
28mm

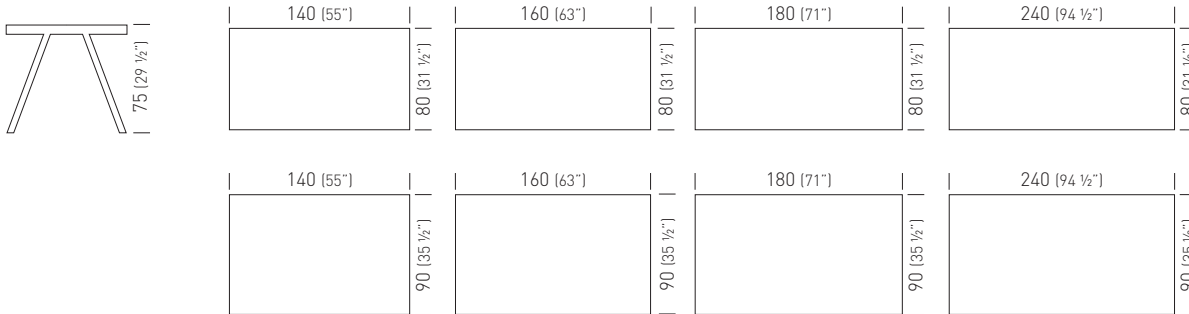

80x140laminated	TSRDL300.___/_/H74	0.41m³ / 32kg / 1pcs	€ <b>901,00</b>
80x160laminated	TSRDL320.___/_/H74	0.51m³ / 35kg / 1pcs	€ <b>1032,00</b>
80x180laminated	TSRDL301.___/_/H74	0.60m³ / 38kg / 1pcs	€ <b>1051,00</b>
80x240laminated	TSRDL302.___/_/H74	0.90m³ / 46.5kg / 1pcs	€ <b>1276,00</b>
90x140laminated	TSRDL303.___/_/H74	0.65m³ / 34kg / 1pcs	€ <b>994,00</b>
90x160laminated	TSRDL321.___/_/H74	0.73m³ / 37kg / 1pcs	€ <b>1070,00</b>
90x180laminated	TSRDL304.___/_/H74	0.80m³ / 40kg / 1pcs	€ <b>1088,00</b>
90x240laminated	TSRDL305.___/_/H74	1.0m³ / 50kg / 1pcs	€ <b>1426,00</b>

## Laminated Top Color / Colore Piano Laminato

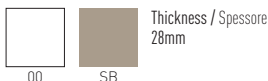

Thickness / Spessore  
28mm

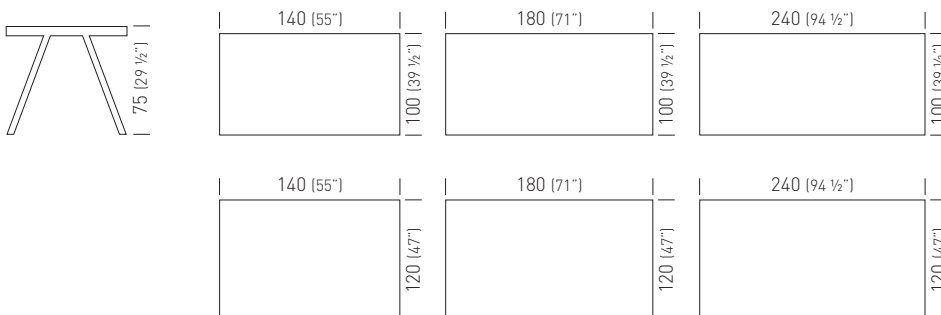

**Option:** Cod. 1101  
Cable Routing Option,  
anodized Aluminum 8x8 cm,  
black brush  
Opzione Passacavi,  
Alluminio anodizzato 8x8 cm  
spazzolina nera  
**€ 124,00**



**Option:** Cod. ACCV030...  
Metal Fairlead Solution  
Tubo metallico passacavi  
**€ 74,00**

Colors / Colori

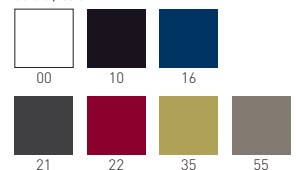

## Surfy Desk 2027

100x140laminated	TSRDL306.___/_/H74	0.70m³ / 40.5kg / 1pcs	€ <b>1088,00</b>
100x180laminated	TSRDL307.___/_/H74	0.85m³ / 49kg / 1pcs	€ <b>1181,00</b>
100x240laminated	TSRDL308.___/_/H74	1.1m³ / 62kg / 1pcs	€ <b>1575,00</b>
120x140laminated	TSRDL309.___/_/H74	0.8m³ / 46kg / 1pcs	€ <b>1238,00</b>
120x180laminated	TSRDL310.___/_/H74	1.0m³ / 56kg / 1pcs	€ <b>1369,00</b>
120x240laminated	TSRDL311.___/_/H74	1.3m³ / 72kg / 1pcs	€ <b>1801,00</b>

## SURFY DESK BRIDGE 2027



### Frame colors / Colori struttura

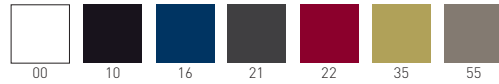

### Laminated Top Color / Colore Piano Laminato

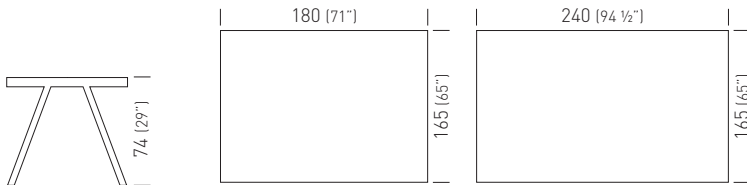
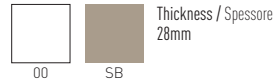

**Option:** Cod. 1101  
Cable Routing Option,  
anodized Aluminum 8x8 cm,  
black brush  
Opzione Passacavi,  
Alluminio anodizzato 8x8 cm  
spazzolina nera  
**€ 124,00**



**Option:** Cod. ACCV030...  
Metal Fairlead Solution  
Tubo metallico passacavi  
**€ 74,00**

165x180laminated	TSRDL314.__-_/H74	0.90m <sup>3</sup> / 87kg / 1pcs	€ <b>2364,00</b>
165x240laminated	TSRDL316.__-_/H74	1.20m <sup>3</sup> / 109kg / 1pcs	€ <b>2700,00</b>

### Table Extension / Modulo Aggiuntivo

165x180laminated	TSRDL315.__-_/H74	0.40m <sup>3</sup> / 77kg / 1pcs	€ <b>2127,00</b>
165x240laminated	TSRDL317.__-_/H74	0.50m <sup>3</sup> / 99kg / 1pcs	€ <b>2432,00</b>

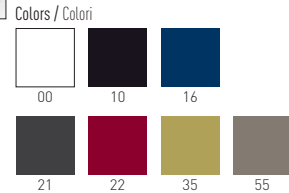

## SURFY HIGH DESK 2027



### Frame colors / Colori struttura



### Laminated Top Color / Colore Piano Laminato

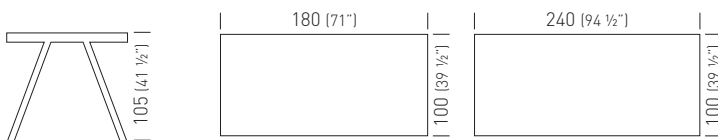
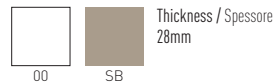

**Option:** Cod. 1101  
Cable Routing Option,  
anodized Aluminum 8x8 cm,  
black brush  
Opzione Passacavi,  
Alluminio anodizzato 8x8 cm  
spazzolina nera  
**€ 124,00**



**Option:** Cod. ACCV030...  
Metal Fairlead Solution  
Tubo metallico passacavi  
**€ 74,00**

100x180laminated	TSRDL307.__-_/H105	0.85m <sup>3</sup> / 57kg / 1pcs	€ <b>1556,00</b>
100x240laminated	TSRDL308.__-_/H105	1.10m <sup>3</sup> / 69kg / 1pcs	€ <b>1838,00</b>

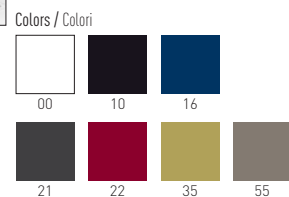



# SURFY DESK 2027 L VERSION



## Frame colors / Colori struttura

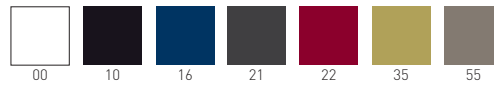

## Laminated Top Color / Colore Piano Laminato

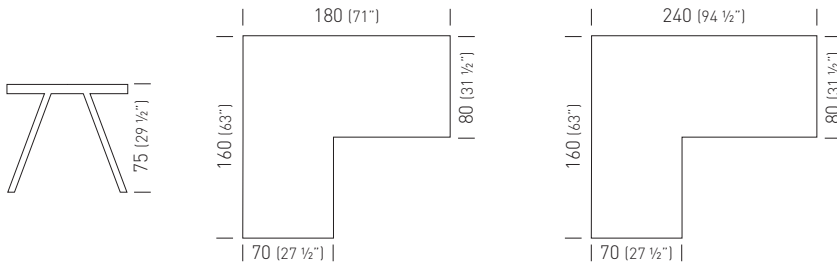
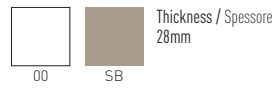

80x180laminated  
80x240laminated

TSRDL330.\_\_-\_\_ / H75  
TSRDL331.\_\_-\_\_ / H75

0.65m³ / 53kg / 1pc  
 0.95m³ / 61.5kg / 1pc

€ **1482,00**  
€ **1697,00**



**Option:** Cod. 1101  
Cable Routing Option,  
anodized Aluminum 8x8 cm,  
black brush  
Opzione Passacavi,  
Alluminio anodizzato 8x8 cm  
spazzolina nera  
**€ 124,00**



**Option:** Cod. ACCV030.\_\_\_  
Metal Fairlead Solution  
Tubo metallico passacavi  
**€ 74,00**

## Colors / Colori

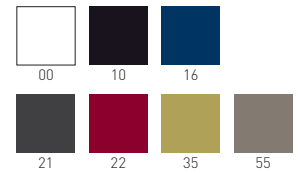

# Surfy Outdoor 2027 Coffee Table

Studio Eurolinea Design

Waiting areas and Coffee Table, Compactop with  
three metal legs frame.

Tavolino attesa con piano in Compactop e  
struttura a tre gambe in metallo.



Frame colors / Colori struttura

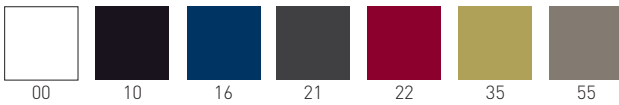

Compactop Color / Colore Piano Compactop

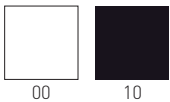

diam.68 compactop	TSROC278.___/H35	0.15m <sup>3</sup> / 11kg / 1pc	€ <b>405,00</b>
diam.68 fullcolor (min 5pcs)	TSROC279.___/H35	0.15m <sup>3</sup> / 11kg / 1pc	€ <b>443,00</b>
diam.68 compactop	TSROC278.___/H50	0.15m <sup>3</sup> / 11.50kg / 1pc	€ <b>412,00</b>
diam.68 fullcolor (min 5pcs)	TSROC279.___/H50	0.15m <sup>3</sup> / 11.50kg / 1pc	€ <b>453,00</b>
diam.80 compactop	TSROC297.___/H50	0.18m <sup>3</sup> / 14kg / 1pc	€ <b>442,00</b>
diam.80 fullcolor (min 5pcs)	TSROC298.___/H50	0.18m <sup>3</sup> / 14kg / 1pc	€ <b>499,00</b>

# Surfy Hub 2027 Coffee Table

Studio Eurolinea Design

Waiting areas and Coffee Table, Laminated  
Table Top with four metal legs frame.

Tavolino attesa con piano in Laminato e struttura  
a 4 gambe in metallo.



Frame colors / Colori struttura

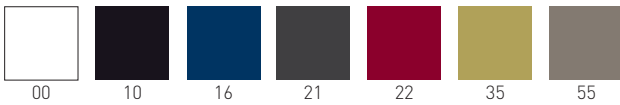

Laminated Top Color / Colore Piano Laminato

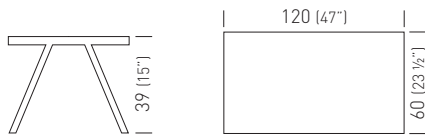
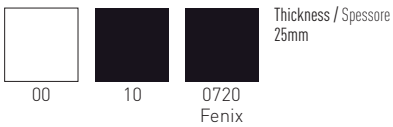

60x120 laminated  
60x120 lam.fenix

TSRHL256.\_\_-\_/H39  
TSRHL256.0720-\_/H39

0.65m³ / 22Kg / 1pc  
 0.65m³ / 22Kg / 1pc

€ **544,00**  
€ **643,00**

# Tag Marble

Ilaria Marelli Design



The Marble tops, characterized by always different veins of natural stones, contribute to enhance elegance and refinement for the most demanding environments. The solid Marble surfaces, shiny and glossy, are treated to reduce their porosity, however constant care and cleaning of the product is recommended.

I piani in Marmo, caratterizzati dalle sempre diverse venature della pietra naturale, offrono eleganza e raffinatezza, per completare con esclusività gli ambienti più ricercati. I solidi piani in Marmo, splendidi e lucidi, sono trattati per ridurre la porosità, tuttavia si consiglia pulizia costante e cura nell'utilizzo del prodotto.

Frame Color / Colore Struttura

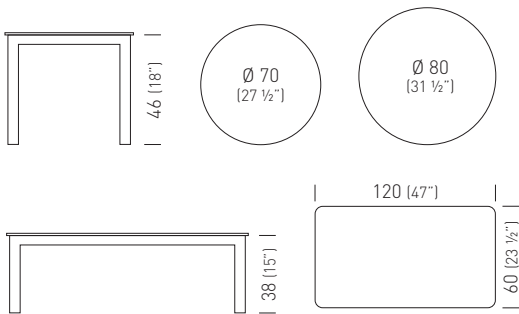
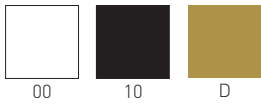

diam. 70	TTAGM403._-_/H45		0.55m <sup>3</sup> / 25kg / 1pc	€	<b>732,00</b>
diam. 80	TTAGM404._-_/H45		0.55m <sup>3</sup> / 31kg / 1pc	€	<b>859,00</b>
60x120	TTAGM405._-_/H37		0.50m <sup>3</sup> / 42kg / 1pc	€	<b>1220,00</b>

# Tag Porcelain

Ilaria Marelli Design

The Porcelain stoneware tops stand out for their excellent technical performance, ideal for the most delicate uses where maximum hygiene and resistance must be guaranteed. Porcelain tops are compatible with foodstuffs, resistant to fungi and molds, suitable for both indoor and outdoor use, resistant to frost, heat and high temperatures, they can be cleaned very easily while maintaining the characteristics of the surface.

I piani in Gres Porcellanato si distinguono per le eccellenti performance tecniche, ideali negli impieghi più delicati nei quali è necessario garantire la massima igiene e resistenza. I piani Porcelain sono compatibili con le sostanze alimentari, resistenti a funghi e muffe, idonei ad un utilizzo sia interno che esterno, resistenti al gelo, al calore e alle alte temperature, si possono pulire con estrema facilità mantenendo inalterate le caratteristiche della superficie.



Frame Color / Colore Struttura



13 mm  
(0.51") CHAMFERED EDGE  
BORDO SMUSSATO



PCO  
CALACATTA ORO



PNG  
NERO GRECO

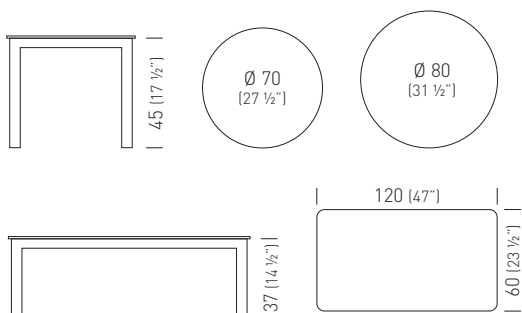

diam. 70  
diam. 80  
60x120

TTAGP407.\_.\_/H45  0.55m<sup>3</sup> / 27kg / 1pc  
TTAGP408.\_.\_/H45  0.55m<sup>3</sup> / 31.5kg / 1pc  
TTAGP409.\_.\_/H37  0.50m<sup>3</sup> / 40kg / 1pc

€ **846,00**  
€ **981,00**  
€ **1023,00**

Min. order 10pcs  
each code  
Ordine min 10pz  
per codice

# Together

Mark Sadler Design



Natural Oak wood table top and polycarbonate legs:  
transparent, solid white, solid black.  
Tavolo con piano in legno di rovere,  
gambe in policarbonato trasparente, bianche o nere.

Technopolymer Frame Color / Colore Struttura Tecnopolimero



00



10



44

Top Color / Colore Piano



RN

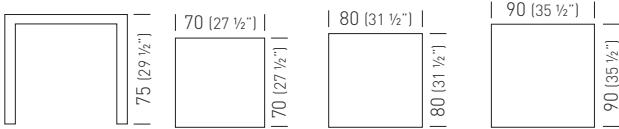

70x70

TTOGL420. \_\_-\_\_ /H75



0.40m<sup>3</sup> / 16kg / 1pcs

€

**938,00**

80x80

TTOGL422. \_\_-\_\_ /H75



0.40m<sup>3</sup> / 18kg / 1pcs

€

**975,00**

90x90

TTOGL424. \_\_-\_\_ /H75



0.40m<sup>3</sup> / 20kg / 1pcs

€

**1032,00**

# Together

Mark Sadler Design

Together is a solid and versatile table, suitable to be utilized with elegance in all modern environments. The legs, made of natural solid oak, are combined with a natural oak veneered top, thus obtaining a pleasant visual play of solid interlocking between the leg and the top. With a simple and elegant design, Together adapts to any decorative context, expressing the warmth of wood and its small details. The legs are always at the extreme of tops sizes.

Together è un tavolo solido e versatile, adatto ad essere inserito con eleganza in tutti gli ambienti moderni. Le gambe, realizzate in rovere massello naturale, sono abbinata ad un piano impiallacciato rovere naturale, ottenendo così un piacevole gioco visivo di solido incastro tra la gamba e il piano. Dal design semplice ed elegante, Together si adatta a qualunque contesto decorativo esprimendo il calore del legno ed i suoi piccoli dettagli. Le gambe restano sempre all'estremo.



Wooden Frame Color / Colore Struttura Legno    Top Color / Colore Piano



RN



RN

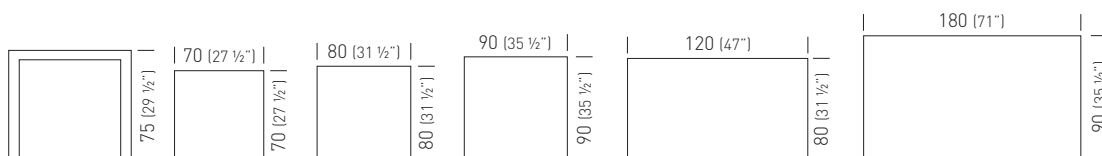

70x70	TTOGL420. _ _ /H75	0.40m <sup>3</sup> / 16kg / 1pcs	€ <b>938,00</b>
80x80	TTOGL422. _ _ /H75	0.40m <sup>3</sup> / 18kg / 1pcs	€ <b>975,00</b>
90x90	TTOGL424. _ _ /H75	0.40m <sup>3</sup> / 20kg / 1pcs	€ <b>1032,00</b>
120x80	TTOGL426. _ _ /H75	0.48m <sup>3</sup> / 24kg / 1pcs	€ <b>1595,00</b>
180x90	TTOGL428. _ _ /H75	0.80m <sup>3</sup> / 33kg / 1pcs	€ <b>2251,00</b>

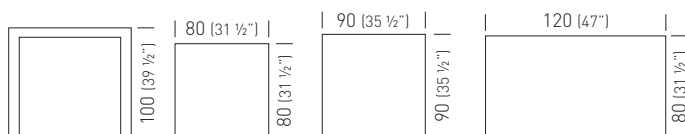

80x80	TTOGL422. _ _ /H100	0.42m <sup>3</sup> / 22kg / 1pcs	€ <b>1125,00</b>
90x90	TTOGL424. _ _ /H100	0.42m <sup>3</sup> / 24kg / 1pcs	€ <b>1163,00</b>
120x80	TTOGL426. _ _ /H100	0.50m <sup>3</sup> / 27kg / 1pcs	€ <b>1762,00</b>

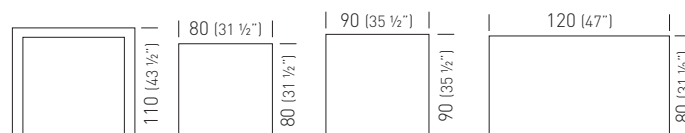

80x80	TTOGL422. _ _ /H110	0.42m <sup>3</sup> / 22kg / 1pcs	€ <b>1181,00</b>
90x90	TTOGL424. _ _ /H110	0.42m <sup>3</sup> / 24kg / 1pcs	€ <b>1220,00</b>
120x80	TTOGL426. _ _ /H110	0.50m <sup>3</sup> / 27kg / 1pcs	€ <b>1783,00</b>

# Woody

Favaretto & Partners Design



Waiting areas and Coffee Table,  
double Compactop deck and beech legs.  
Tavolino attesa con doppio piano Compactop  
e gambe in legno di faggio.

Wooden Frame Color / Colore Struttura Legno



F

Top Color / Colore Piano



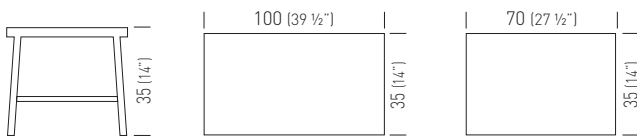

00

Fullcolor



100x35  
70x35

TWOOC132.00-F/H35  
TWOOC130.00-F/H35

 0.18m<sup>3</sup> / 12kg / 1pcs  
 0.13m<sup>3</sup> / 9kg / 1pcs

€ **386,00**  
€ **363,00**





# TKITT Collection

TABLES FOR INDOOR AND OUT



# TKITT.BG3K

H75 Table with technopolymer top, BG3K 3-spur metal-technopolymer co-injected table base, Ø 80mm anodized aluminum column.

Tavolo con piano in tecnopolimero H75, basamento BG3K a tre razze in metallo sovrastampato con tecnopolimero, colonna in alluminio anodizzato Ø 80mm.

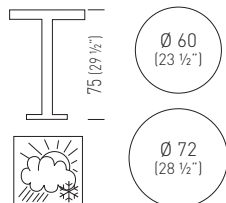

■ TKITT04._/BG3K		0.13m³ / 13.8kg / 1pcs	€	<b>243,00</b>
■ TKITT04._/BG3K.10		0.13m³ / 13.8kg / 1pcs	€	<b>267,00</b>

■ TKITT03._/BG3K		0.15m³ / 14.5kg / 1pcs	€	<b>265,00</b>
■ TKITT03._/BG3K.10		0.15m³ / 14.5kg / 1pcs	€	<b>291,00</b>

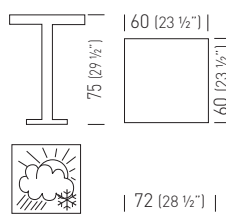

■ TKITT20._/BG3K		0.13m³ / 14.6kg / 1pcs	€	<b>256,00</b>
■ TKITT20._/BG3K.10		0.13m³ / 14.6kg / 1pcs	€	<b>284,00</b>

■ TKITT06._/BG3K		0.15m³ / 15.8kg / 1pcs	€	<b>291,00</b>
■ TKITT06._/BG3K.10		0.15m³ / 15.8kg / 1pcs	€	<b>318,00</b>

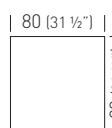

■ TKITT23._/BG3K		0.16m³ / 18.4kg / 1pcs	€	<b>304,00</b>
■ TKITT23._/BG3K.10		0.16m³ / 18.4kg / 1pcs	€	<b>335,00</b>

Top Color / Colore Piano



# TKITT.BG3L

H75 Table with technopolymer top, BG3L 3-spur metal-technopolymer co-injected table base, Ø 80mm anodized aluminum column.

Tavolo con piano in tecnopolimero H75, basamento BG3L a tre razze in metallo sovrastampato con tecnopolimero, colonna in alluminio anodizzato Ø 80mm.

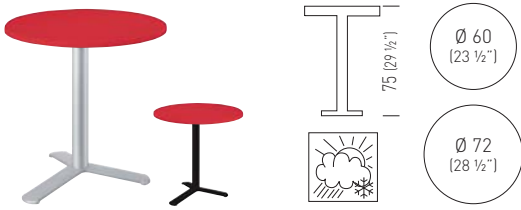

■ TKITT04._/BG3L		0.14m³ / 15kg / 1pcs	€	<b>243,00</b>
■ TKITT04._/BG3L.10		0.14m³ / 15kg / 1pcs	€	<b>267,00</b>

■ TKITT03._/BG3L		0.16m³ / 15.7kg / 1pcs	€	<b>265,00</b>
■ TKITT03._/BG3L.10		0.16m³ / 15.7kg / 1pcs	€	<b>291,00</b>

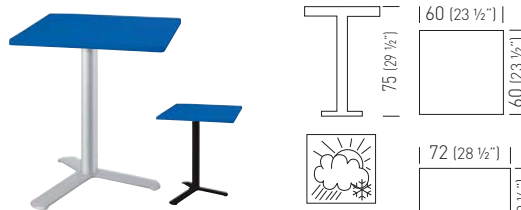

■ TKITT20._/BG3L		0.14m³ / 15.8kg / 1pcs	€	<b>256,00</b>
■ TKITT20._/BG3L.10		0.14m³ / 15.8kg / 1pcs	€	<b>284,00</b>

■ TKITT06._/BG3L		0.16m³ / 17kg / 1pcs	€	<b>291,00</b>
■ TKITT06._/BG3L.10		0.16m³ / 17kg / 1pcs	€	<b>318,00</b>

■ TKITT23._/BG3L		0.17m³ / 19.6kg / 1pcs	€	<b>304,00</b>
■ TKITT23._/BG3L.10		0.17m³ / 19.6kg / 1pcs	€	<b>335,00</b>

# TKITT.BGA3L

H110 Table with technopolymer top, BG3L 3-spur metal-technopolymer co-injected table base, Ø 80mm anodized aluminum column.

Tavolo con piano in tecnopolimero H110, basamento BG3L a tre razze in metallo sovrastampato con tecnopolimero, colonna in alluminio anodizzato Ø 80mm.

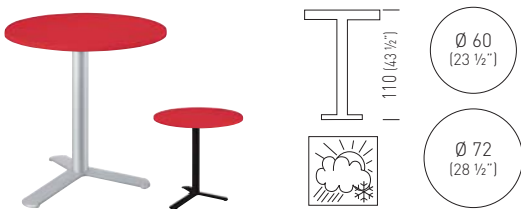

■ TKITT04._/BGA3L		0.18m³ / 15.8kg / 1pcs	€	<b>307,00</b>
■ TKITT04._/BGA3L.10		0.18m³ / 15.8kg / 1pcs	€	<b>338,00</b>

■ TKITT03._/BGA3L		0.20m³ / 16.5kg / 1pcs	€	<b>330,00</b>
■ TKITT03._/BGA3L.10		0.20m³ / 16.5kg / 1pcs	€	<b>361,00</b>

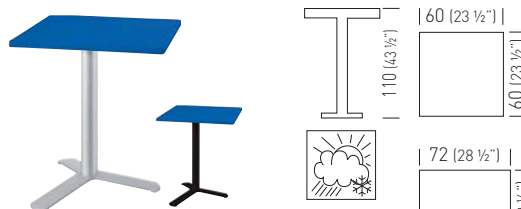

■ TKITT20._/BGA3L		0.18m³ / 16.6kg / 1pcs	€	<b>321,00</b>
■ TKITT20._/BGA3L.10		0.18m³ / 16.6kg / 1pcs	€	<b>353,00</b>

■ TKITT06._/BGA3L		0.20m³ / 17.8kg / 1pcs	€	<b>322,00</b>
■ TKITT06._/BGA3L.10		0.20m³ / 17.8kg / 1pcs	€	<b>355,00</b>

Top Color / Colore Piano



# TKITT.BG4K

H75 Table with technopolymer top, BG4K 4-spur metal-technopolymer co-injected table base, Ø 80mm anodized aluminum column.

Tavolo con piano in tecnopolimero H75, basamento BG4K a quattro razze in metallo sovrastampato con tecnopolimero, colonna in alluminio anodizzato Ø 80mm.

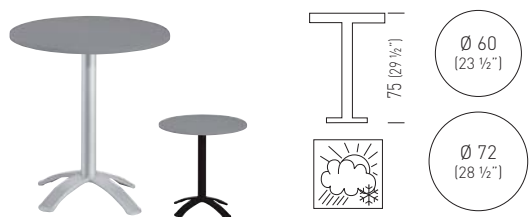

■ TKITT04._/BG4K		0.13m³ / 16.5kg / 1pcs	€	<b>256,00</b>
■ TKITT04._/BG4K.10		0.13m³ / 16.5kg / 1pcs	€	<b>284,00</b>

■ TKITT03._/BG4K		0.15m³ / 17.2kg / 1pcs	€	<b>276,00</b>
■ TKITT03._/BG4K.10		0.15m³ / 17.2kg / 1pcs	€	<b>305,00</b>



■ TKITT20._/BG4K		0.13m³ / 17.3kg / 1pcs	€	<b>268,00</b>
■ TKITT20._/BG4K.10		0.13m³ / 17.3kg / 1pcs	€	<b>295,00</b>

■ TKITT06._/BG4K		0.15m³ / 18.5kg / 1pcs	€	<b>304,00</b>
■ TKITT06._/BG4K.10		0.15m³ / 18.5kg / 1pcs	€	<b>335,00</b>

■ TKITT23._/BG4K		0.16m³ / 21.1kg / 1pcs	€	<b>318,00</b>
■ TKITT23._/BG4K.10		0.16m³ / 21.1kg / 1pcs	€	<b>350,00</b>

# TKITT.BGA4K

H115 Table with technopolymer top, BG4K 4-spur metal-technopolymer co-injected table base, Ø 80mm anodized aluminum column.

Tavolo con piano in tecnopolimero H115, basamento BG4K a quattro razze in metallo sovrastampato con tecnopolimero, colonna in alluminio anodizzato Ø 80mm.

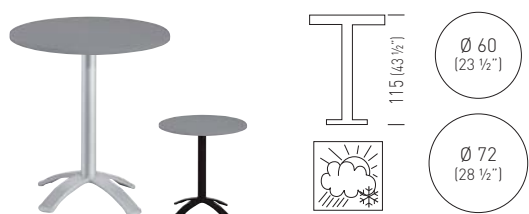

■ TKITT04._/BGA4K		0.17m³ / 17.3kg / 1pcs	€	<b>338,00</b>
■ TKITT04._/BGA4K.10		0.17m³ / 17.3kg / 1pcs	€	<b>374,00</b>

■ TKITT03._/BGA4K		0.19m³ / 18kg / 1pcs	€	<b>358,00</b>
■ TKITT03._/BGA4K.10		0.19m³ / 18kg / 1pcs	€	<b>395,00</b>



■ TKITT20._/BGA4K		0.17m³ / 18.1kg / 1pcs	€	<b>352,00</b>
■ TKITT20._/BGA4K.10		0.17m³ / 18.1kg / 1pcs	€	<b>388,00</b>

■ TKITT06._/BGA4K		0.19m³ / 19.3kg / 1pcs	€	<b>388,00</b>
■ TKITT06._/BGA4K.10		0.19m³ / 19.3kg / 1pcs	€	<b>426,00</b>











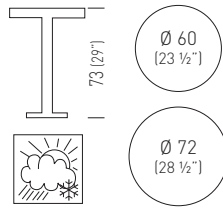

Top Color / Colore Piano

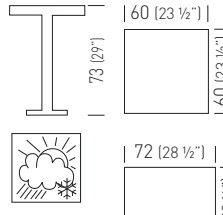

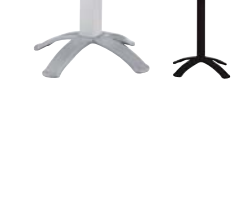
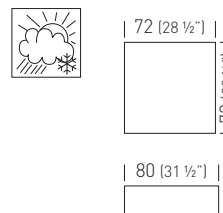
# TKITT.BG4J

H73 Table with technopolymer top, BG4J 4-spur metal-technopolymer co-injected table base, 80x80mm anodized aluminum column.

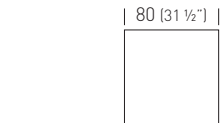









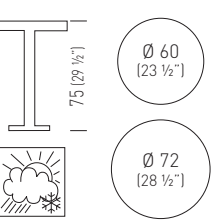



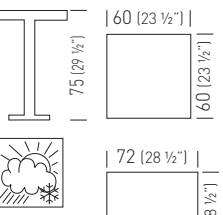

Tavolo con piano in tecnopolimero H73, basamento BG4J a quattro razze in metallo sovrastampato con tecnopolimero, colonna in alluminio anodizzato 80x80mm.

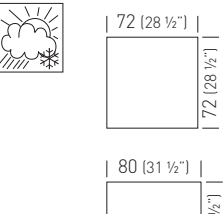
		■ TKITT04._/BG4J  0.16m <sup>3</sup> / 16.8kg / 1pcs <span style="float: right;">€ <b>268,00</b></span>
		■ TKITT04._/BG4J.10  0.16m <sup>3</sup> / 16.8kg / 1pcs <span style="float: right;">€ <b>295,00</b></span>
		■ TKITT20._/BG4J  0.16m <sup>3</sup> / 17.6kg / 1pcs <span style="float: right;">€ <b>284,00</b></span>
		■ TKITT20._/BG4J.10  0.16m <sup>3</sup> / 17.6kg / 1pcs <span style="float: right;">€ <b>310,00</b></span>
		■ TKITT06._/BG4J  0.18m <sup>3</sup> / 18.8kg / 1pcs <span style="float: right;">€ <b>316,00</b></span>
		■ TKITT06._/BG4J.10  0.18m <sup>3</sup> / 18.8kg / 1pcs <span style="float: right;">€ <b>347,00</b></span>
		■ TKITT23._/BG4J  0.19m <sup>3</sup> / 21.4kg / 1pcs <span style="float: right;">€ <b>330,00</b></span>
		■ TKITT23._/BG4J.10  0.19m <sup>3</sup> / 21.4kg / 1pcs <span style="float: right;">€ <b>361,00</b></span>

# TKITT.BGPK

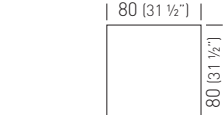
H75 folding table with technopolymer top, BG4J 4-spur metal-technopolymer co-injected base, Ø 80mm anodized aluminum column with flip-top mechanism.

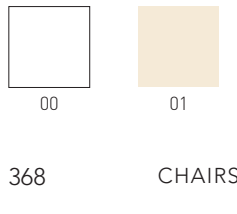
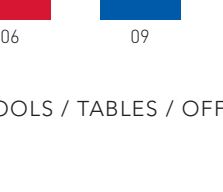
Tavolo pieghevole con piano in tecnopolimero H75, basamento BGPK a quattro razze in metallo sovrastampato con tecnopolimero, colonna in alluminio anodizzato Ø 80mm.

		■ TKITT04._/BGPK  0.13m <sup>3</sup> / 17.5kg / 1pcs <span style="float: right;">€ <b>377,00</b></span>
		■ TKITT04._/BGPK.10  0.13m <sup>3</sup> / 17.5kg / 1pcs <span style="float: right;">€ <b>414,00</b></span>
		■ TKITT03._/BGPK  0.15m <sup>3</sup> / 18.2kg / 1pcs <span style="float: right;">€ <b>398,00</b></span>
		■ TKITT03._/BGPK.10  0.15m <sup>3</sup> / 18.2kg / 1pcs <span style="float: right;">€ <b>442,00</b></span>
		■ TKITT20._/BGPK  0.13m <sup>3</sup> / 18.3kg / 1pcs <span style="float: right;">€ <b>392,00</b></span>
		■ TKITT20._/BGPK.10  0.13m <sup>3</sup> / 18.3kg / 1pcs <span style="float: right;">€ <b>431,00</b></span>
		■ TKITT06._/BGPK  0.15m <sup>3</sup> / 19.5kg / 1pcs <span style="float: right;">€ <b>428,00</b></span>
		■ TKITT06._/BGPK.10  0.15m <sup>3</sup> / 19.5kg / 1pcs <span style="float: right;">€ <b>471,00</b></span>
		■ TKITT23._/BGPK  0.16m <sup>3</sup> / 22.1kg / 1pcs <span style="float: right;">€ <b>439,00</b></span>
		■ TKITT23._/BGPK.10  0.16m <sup>3</sup> / 22.1kg / 1pcs <span style="float: right;">€ <b>482,00</b></span>

Top Color / Colore Piano



# TKITT.BGPJ

H75 folding table with technopolymer top, BG4J 4-spur metal-technopolymer co-injected base, 80x80mm anodized aluminum column with flip-top mechanism.

Tavolo pieghevole con piano in tecnopolimero H75, basamento BGPK a quattro razze in metallo sovrastampato con tecnopolimero, colonna in alluminio anodizzato 80x80mm.

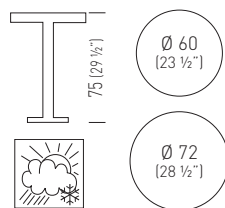

■ TKITT04._/BGPJ		0.16m <sup>3</sup> / 17.8kg / 1pcs	€ <b>389,00</b>
■ TKITT04._/BGPJ.10		0.16m <sup>3</sup> / 17.8kg / 1pcs	€ <b>428,00</b>

■ TKITT03._/BGPJ		0.18m <sup>3</sup> / 18.5kg / 1pcs	€ <b>412,00</b>
■ TKITT03._/BGPJ.10		0.18m <sup>3</sup> / 18.5kg / 1pcs	€ <b>453,00</b>

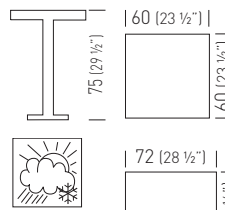

■ TKITT20._/BGPJ		0.16m <sup>3</sup> / 18.6kg / 1pcs	€ <b>405,00</b>
■ TKITT20._/BGPJ.10		0.16m <sup>3</sup> / 18.6kg / 1pcs	€ <b>445,00</b>

■ TKITT06._/BGPJ		0.18m <sup>3</sup> / 19.8kg / 1pcs	€ <b>437,00</b>
■ TKITT06._/BGPJ.10		0.18m <sup>3</sup> / 19.8kg / 1pcs	€ <b>481,00</b>

■ TKITT23._/BGPJ		0.19m <sup>3</sup> / 22.4kg / 1pcs	€ <b>450,00</b>
■ TKITT23._/BGPJ.10		0.19m <sup>3</sup> / 22.4kg / 1pcs	€ <b>494,00</b>

# TKITT.BG4IP

Folding and stacking H75 table with technopolymer top, BG4IP 4-spur metal-technopolymer co-injected table base, Ø 80mm anodized aluminum column with flip-top mechanism and adjustable feet.

Tavolo pieghevole e accatastabile con piano in tecnopolimero H75, basamento BG4IP a quattro razze in metallo sovrastampato con tecnopolimero, colonna in alluminio anodizzato Ø 80mm e piedini regolabili.

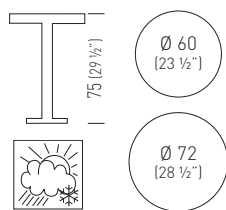

■ TKITT04._/BG4IP		0.13m <sup>3</sup> / 14kg / 1pcs	€ <b>439,00</b>
■ TKITT04._/BG4IP.10		0.13m <sup>3</sup> / 14kg / 1pcs	€ <b>482,00</b>

■ TKITT03._/BG4IP		0.15m <sup>3</sup> / 14.7kg / 1pcs	€ <b>465,00</b>
■ TKITT03._/BG4IP.10		0.15m <sup>3</sup> / 14.7kg / 1pcs	€ <b>510,00</b>

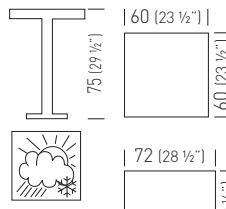

■ TKITT20._/BG4IP		0.13m <sup>3</sup> / 14.8kg / 1pcs	€ <b>456,00</b>
■ TKITT20._/BG4IP.10		0.13m <sup>3</sup> / 14.8kg / 1pcs	€ <b>501,00</b>

■ TKITT06._/BG4IP		0.15m <sup>3</sup> / 16kg / 1pcs	€ <b>490,00</b>
■ TKITT06._/BG4IP.10		0.15m <sup>3</sup> / 16kg / 1pcs	€ <b>539,00</b>

■ TKITT23._/BG4IP		0.16m <sup>3</sup> / 18.5kg / 1pcs	€ <b>504,00</b>
■ TKITT23._/BG4IP.10		0.16m <sup>3</sup> / 18.5kg / 1pcs	€ <b>555,00</b>

Top Color / Colore Piano





# TKITT.BTK

H75 Table with technopolymer top, round BTK metal-technopolymer co-injected base, Ø 80mm anodized aluminum column.

Tavolo con piano in tecnopolimero H75, basamento BTK rotondo in metallo sovrastampato con tecnopolimero, colonna in alluminio anodizzato Ø 80mm.

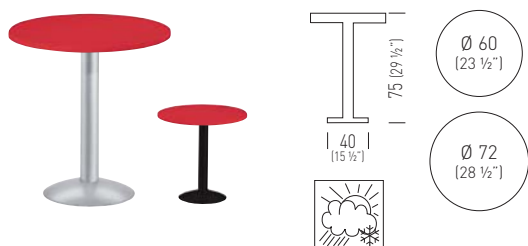

■ TKITT04._/BTK	0.16m³ / 13.8kg / 1pcs	€ <b>214,00</b>
■ TKITT04._/BTK.10	0.16m³ / 13.8kg / 1pcs	€ <b>236,00</b>
■ TKITT03._/BTK	0.18m³ / 14.5kg / 1pcs	€ <b>236,00</b>
■ TKITT03._/BTK.10	0.18m³ / 14.5kg / 1pcs	€ <b>260,00</b>

# TKITT.BTAK

H110 Table with technopolymer top, round BTAK metal-technopolymer co-injected base, Ø 80mm anodized aluminum column.

Tavolo con piano in tecnopolimero H110, basamento BTAK rotondo in metallo sovrastampato con tecnopolimero, colonna in alluminio anodizzato Ø 80mm.

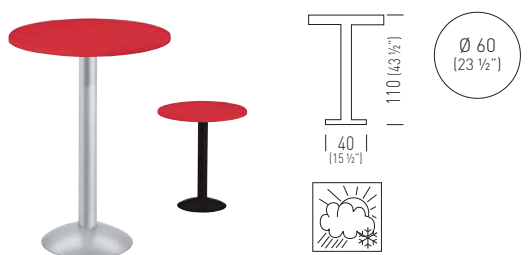

■ TKITT04._/BTAK	0.17m³ / 14.8kg / 1pcs	€ <b>262,00</b>
■ TKITT04._/BTAK.10	0.17m³ / 14.8kg / 1pcs	€ <b>288,00</b>

Top Color / Colore Piano



# TKITT.BTK54

H75 Table with technopolymer top, round BTK54 metal-technopolymer co-injected table base, Ø 80mm anodized aluminum column.

Tavolo con piano in tecnopolimero H75, basamento BTK54 rotondo in metallo sovrastampato con tecnopolimero, colonna in alluminio anodizzato Ø 80mm.

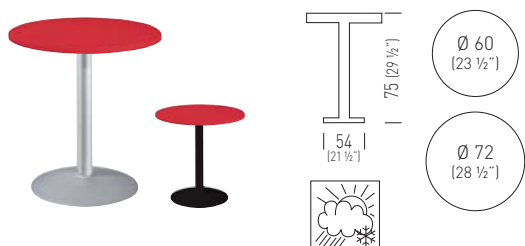

■ TKITT04._/BTK54		0.16m³ / 16.3kg / 1pcs	€	<b>242,00</b>
■ TKITT04._/BTK54.10		0.16m³ / 16.3kg / 1pcs	€	<b>265,00</b>
■ TKITT03._/BTK54		0.18m³ / 17kg / 1pcs	€	<b>262,00</b>
■ TKITT03._/BTK54.10		0.18m³ / 17kg / 1pcs	€	<b>288,00</b>

# TKITT.BTAK54

H110 Table with technopolymer top, round BTK54 metal-technopolymer co-injected table base, Ø 80mm anodized aluminum column.

Tavolo con piano in tecnopolimero H110, basamento BTAK54 rotondo in metallo sovrastampato con tecnopolimero, colonna in alluminio anodizzato Ø 80mm.

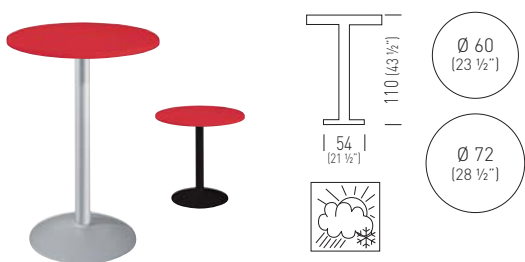

■ TKITT04._/BTAK54		0.17m³ / 17.3kg / 1pcs	€	<b>293,00</b>
■ TKITT04._/BTAK54.10		0.17m³ / 17.3kg / 1pcs	€	<b>321,00</b>
■ TKITT03._/BTAK54		0.19m³ / 18kg / 1pcs	€	<b>313,00</b>
■ TKITT03._/BTAK54.10		0.19m³ / 18kg / 1pcs	€	<b>347,00</b>

Top Color / Colore Piano



# TKITT.DPBT54

H110 double table with technopolymer tops, round DPBT54 metal-technopolymer co-injected base, Ø 80mm anodized aluminum column.

Tavolo con doppio piano in tecnopolimero H110, basamento DPBT54 rotondo in metallo sovrastampato con tecnopolimero, colonna in alluminio anodizzato Ø 80mm.

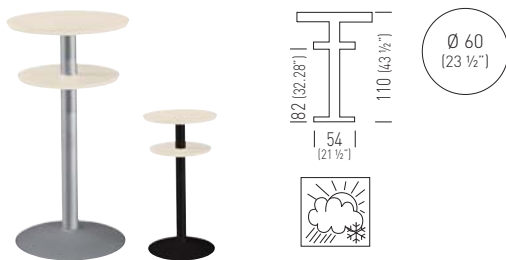

■ TKITT08.__/DPBT54		0.15m³ / 16.5kg / 1pcs	€	<b>363,00</b>
■ TKITT08.__/DPBT54.10		0.15m³ / 16.5kg / 1pcs	€	<b>397,00</b>

# TKITT.BRK

H75 Table with technopolymer top, round BRK metal-technopolymer co-injected base, Ø 80mm anodized aluminum column.

Tavolo con piano in tecnopolimero H75, basamento BRK rotondo in metallo sovrastampato con tecnopolimero, colonna in alluminio anodizzato Ø 80mm.

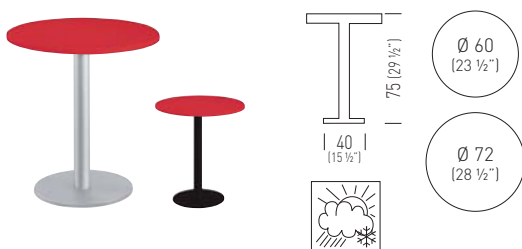

■ TKITT04.__/BRK		0.13m³ / 14.3kg / 1pcs	€	<b>220,00</b>
■ TKITT04.__/BRK.10		0.13m³ / 14.3kg / 1pcs	€	<b>242,00</b>
■ TKITT03.__/BRK		0.15m³ / 15kg / 1pcs	€	<b>242,00</b>
■ TKITT03.__/BRK.10		0.15m³ / 15kg / 1pcs	€	<b>265,00</b>

Top Color / Colore Piano



# TKITT.BQJ

H74 Table with technopolymer top, square BQJ metal-technopolymer co-injected table base, 80x80mm anodized aluminum column.

Tavolo con piano in tecnopolimero H74, basamento BQJ quadrato in metallo sovrastampato con tecnopolimero, colonna in alluminio anodizzato 80x80mm.

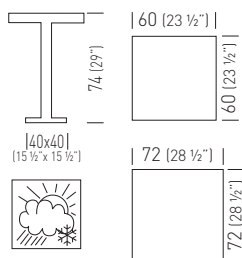

■ TKITT20._/BQJ		0.13m <sup>3</sup> / 17.1kg / 1pcs	€	<b>250,00</b>
■ TKITT20._/BQJ.10		0.13m <sup>3</sup> / 17.1kg / 1pcs	€	<b>273,00</b>
■ TKITT06._/BQJ		0.15m <sup>3</sup> / 18.3kg / 1pcs	€	<b>285,00</b>
■ TKITT06._/BQJ.10		0.15m <sup>3</sup> / 18.3kg / 1pcs	€	<b>312,00</b>

# TKITT.BQAJ

H103 Table with technopolymer top, square BQJ metal-technopolymer co-injected table base, 80x80mm anodized aluminum column.

Tavolo con piano in tecnopolimero H103, basamento BQJ quadrato in metallo sovrastampato con tecnopolimero, colonna in alluminio anodizzato 80x80mm.

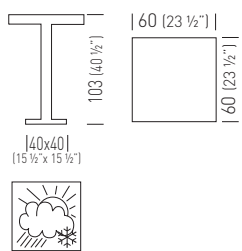

■ TKITT20._/BQAJ		0.14m <sup>3</sup> / 17.6kg / 1pcs	€	<b>307,00</b>
■ TKITT20._/BQAJ.10		0.14m <sup>3</sup> / 17.6kg / 1pcs	€	<b>338,00</b>

Top Color / Colore Piano



# TIMPT.STAKY

Stackable table collection, suitable for outdoor use.  
Techno polymer tops and anodized aluminum frames.

Collezione di tavoli impilabili, adatti all'uso esterno.  
I tavoli sono realizzati con piani in tecnopolimero e struttura in alluminio anodizzato.

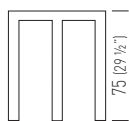

TIMPT04.\_/H75

0.08m³ / 7.1kg / 1pcs

€ **183,00**

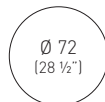

TIMPT03.\_/H75

0.08m³ / 7.3kg / 1pcs

€ **189,00**

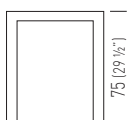

| 60 (23 1/2" ) |



TIMPT20.\_/H75

0.05m³ / 7.6kg / 1pcs

€ **222,00**

| 80 (31 1/2" ) |



TIMPT23.\_/H75

0.09m³ / 8kg / 1pcs

€ **260,00**

Top Color / Colore Piano



00



01



06



09



10



14



42



52



99

# TCONT.STEADY

Counterbalanced tables collection, suitable for outdoor use.  
Techno polymer tops and anodized aluminum frames.

Collezione di tavoli a contrappesi, adatti all'uso esterno.  
I tavoli sono realizzati con piani in tecnopolimero e struttura in alluminio anodizzato.

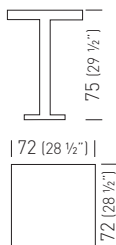

TCONT06.\_/H75

 0.08m<sup>3</sup> / 12.8kg / 1pcs € **260,00**

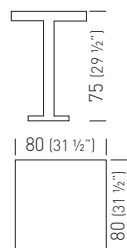

TCONT23.\_/H75

 0.10m<sup>3</sup> / 13kg / 1pcs € **284,00**

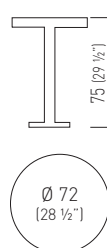

TCONT03.\_/H75

 0.08m<sup>3</sup> / 12.6kg / 1pcs € **240,00**

Top Color / Colore Piano



00



01



06



09



10



14



42



52



99

# Standard Compactop Surfaces



Flat black edge  
Bordo piatto nero

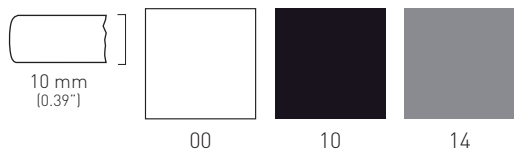

Flat black edge  
Bordo piatto nero

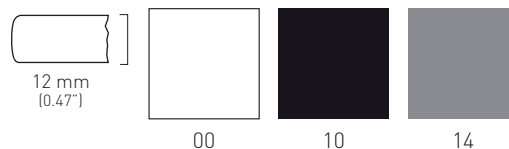

Sizes / Misure	Code / Codice		€
Ø 60 (23 ½")	PTC101._	0.054m³ / 11kg / 2pcs	<b>198,00</b>
Ø 68 (27")	PTC103._	0.074m³ / 13kg / 2pcs	<b>237,00</b>
59x59 (23"x23")	PTC102._	0.054m³ / 12kg / 2pcs	<b>157,00</b>
68x68 (27"x27")	PTC104._	0.074m³ / 19kg / 2pcs	<b>183,00</b>
79x79 (31"x31")	PTC106._	0.090m³ / 20kg / 2pcs	<b>206,00</b>
89x89 (35"x35")	PTC107._	0.11m³ / 25kg / 2pcs	<b>279,00</b>

Sizes / Misure	Code / Codice		€
Ø 80 (31 ½")	PTC105._	0.09m³ / 19kg / 2pcs	<b>276,00</b>
Ø 100 (39 ½")	PTC108._	0.20m³ / 31kg / 2pcs	<b>425,00</b>
Ø 120 (47")	PTC109._	0.26m³ / 44kg / 2pcs	<b>592,00</b>
Ø 140 (55")	PTC115._	0.30m³ / 50kg / 2pcs	<b>603,00</b>
120x50 (47"x19 ½")	PTC110._	0.20m³ / 23kg / 2pcs	<b>295,00</b>
140x70 (55"x27 ½")	PTC111._	0.20m³ / 40kg / 2pcs	<b>405,00</b>
120x80 (47"x31 ½")	PTC112._	0.20m³ / 33kg / 2pcs	<b>389,00</b>
159x79 (62 ½"x31")	PTC114._	0.26m³ / 46kg / 2pcs	<b>448,00</b>

## ABOUT COMPACTOP: MUCH MORE THAN A MERE SURFACE

Gaber Compactops are made of high-pressure laminate, consisting of numerous layers of paper saturated with thermosetting resins and bonded through the combined action of heat and high pressure. The paper used on Compactop (around 70% of the complete composition) comes from production processes that conform with the FSC chain of custody; phenolic and melamine resins are all strictly water-based.

The result is a stable, non-reactive, homogenous, non-porous, antistatic, high-density product with a totally distinct physical and chemical profile from that of its constituent parts. Thanks to the heat and high-pressure treatment it they undergo, Gaber Compactops are exceptionally tough and resistant to scratches, abrasions, chemicals and heat, making them ideal for a wide range of contract applications. Tops come pre-bored for Gaber kit bases.

Gaber Compactops conform to EN 438/1. According to this norm, the most important characteristics of Gaber Compactops are: their resistance to bumps, scratches, and wear and tear; color-fastness; easy cleanability; suitable for contact with food and general hygiene.

UNI EN 438 is the reference standard for Compactop Gaber tops. This standard prescribes tolerances in the flatness of the product and on possible stains and other similar surface defects, for which the admissible size is based on a maximum contamination area equivalent to 1mm² / m² of laminate, concentrated in a single point or distributed in more points, proportional to the size of the sheet under inspection.

## MAINTENANCE & CLEANING

No specific maintenance other than normal cleaning is required. The compact, non porous surface can easily be cleaned and disinfected with hot water, steam and any common non-abrasive household detergents and disinfectants, as long as these are not highly alkaline. Just a couple of precautions are necessary: avoid using strong acids and bases and avoid wiping with highly abrasive substances or equipment.

## CHE COS'È IL COMPACTOP? MOLTO PIÙ DI UNA SEMPLICE SUPERFICIE

Il Compactop che Gaber utilizza per i propri tavoli è un laminato realizzato ad alta pressione, costituito da numerosi strati di carta impregnati con resine termoindurenti fenoliche e melaminiche, compattati attraverso l'azione combinata di calore ed alta pressione. Le carte utilizzate (circa il 70% della composizione dei piani) derivano da processi che seguono il protocollo della catena di custodia certificata FSC; le resine fenoliche e melaminiche sono tutte rigorosamente realizzate su base acquosa.

Il risultato è un prodotto stabile, non reattivo, omogeneo, non poroso, antistatico e di alta densità. Grazie al trattamento di alta temperatura e pressione cui è sottoposto, il Compactop è un materiale estremamente robusto: resistente a graffi, urti, abrasioni, sostanze chimiche e calore; caratteristiche che lo rendono il materiale ideale per una vasta gamma di applicazioni. I fissaggi dei piani Compactop sono già predisposti per i basamenti Gaber.

Il Compactop è conforme alla norma EN 438/1, secondo la quale, queste sono le principali caratteristiche di qualità di questo materiale: Resistente all'impatto, ai graffi e all'usura, stabile alla luce, facile da pulire, igienico, adatto al contatto con i cibi.

La UNI EN 438 è la norma di riferimento dei piani in Compactop Gaber. Tale normativa prescrive tolleranze nella planarità del prodotto e su possibili macchie e altri difetti superficiali simili, per i quali la dimensione ammissibile è basata su un'area di contaminazione massima equivalente a 1mm²/m² di laminato, concentrata in un unico punto o dispersa in più punti, proporzionale alla dimensione del foglio sottoposto a ispezione.

## MANUTENZIONE E PULIZIA

Il Compactop non richiede alcuna manutenzione particolare al di là della normale pulizia.

La sua superficie compatta e non porosa può essere facilmente pulita e disinfettata con acqua calda, vapore e tutti i tipi dei più comuni detergenti e disinfettanti per uso domestico, purché non alcalini. Sono necessarie solo poche precauzioni, quali evitare l'uso di acidi o basi forti, evitare di strofinare con sostanze o strumenti fortemente abrasivi.

# Special Compactop Surfaces

## Fullcolor



The white color of Compactop Fullcolor Surface is specific as it is combined with the color of the edge.  
Il colore bianco del Compactop Fullcolor è specifico in quanto abbinato al colore del bordo



Chamfered edge  
Bordo smussato

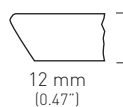

00

(min. 5pcs each code)  
(min. 5pcs per codice)

Flat edge  
Bordo piatto

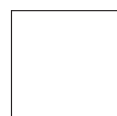
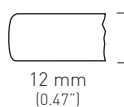

00

(min. 5pcs each code)  
(min. 5pcs per codice)

Sizes / Misure	Code / Codice		€	Sizes / Misure	Code / Codice		€
Ø 60 (23 1/2")	PTC301.00	0.054m³ / 12kg / 2pcs	<b>237,00</b>	Ø 60 (23 1/2")	PTC201.00	0.054m³ / 12kg / 2pcs	<b>237,00</b>
Ø 68 (27")	PTC303.00	0.074m³ / 14kg / 2pcs	<b>284,00</b>	Ø 68 (27")	PTC203.00	0.074m³ / 14kg / 2pcs	<b>284,00</b>
Ø 80 (31 1/2")	PTC305.00	0.09m³ / 19kg / 2pcs	<b>330,00</b>	Ø 80 (31 1/2")	PTC205.00	0.09m³ / 19kg / 2pcs	<b>330,00</b>
Ø 100 (39 1/2")	PTC308.00	0.20m³ / 31kg / 2pcs	<b>732,00</b>	Ø 100 (39 1/2")	PTC208.00	0.20m³ / 31kg / 2pcs	<b>732,00</b>
Ø 120 (47")	PTC309.00	0.26m³ / 44kg / 2pcs	<b>750,00</b>	Ø 120 (47")	PTC209.00	0.26m³ / 44kg / 2pcs	<b>750,00</b>
Ø 140 (55")	PTC315.00	0.30m³ / 50kg / 2pcs	<b>806,00</b>	Ø 140 (55")	PTC215.00	0.30m³ / 50kg / 2pcs	<b>806,00</b>
59x59 (23"x23")	PTC302.00	0.054m³ / 13kg / 2pcs	<b>188,00</b>	59x59 (23"x23")	PTC202.00	0.054m³ / 13kg / 2pcs	<b>188,00</b>
68x68 (27"x27")	PTC304.00	0.074m³ / 21kg / 2pcs	<b>217,00</b>	68x68 (27"x27")	PTC204.00	0.074m³ / 21kg / 2pcs	<b>217,00</b>
79x79 (31"x31")	PTC306.00	0.090m³ / 22kg / 2pcs	<b>248,00</b>	79x79 (31"x31")	PTC206.00	0.090m³ / 22kg / 2pcs	<b>248,00</b>
89x89 (35"x35")	PTC307.00	0.11m³ / 27kg / 2pcs	<b>335,00</b>	89x89 (35"x35")	PTC207.00	0.11m³ / 27kg / 2pcs	<b>335,00</b>
120x50 (47"x19 1/2")	PTC310.00	0.20m³ / 23kg / 2pcs	<b>355,00</b>	120x50 (47"x19 1/2")	PTC210.00	0.20m³ / 23kg / 2pcs	<b>355,00</b>
140x70 (55"x27 1/2")	PTC311.00	0.20m³ / 40kg / 2pcs	<b>484,00</b>	140x70 (55"x27 1/2")	PTC211.00	0.20m³ / 40kg / 2pcs	<b>484,00</b>
120x80 (47"x31 1/2")	PTC312.00	0.20m³ / 33kg / 2pcs	<b>463,00</b>	120x80 (47"x31 1/2")	PTC212.00	0.20m³ / 33kg / 2pcs	<b>463,00</b>
159x79 (62 1/2"x31")	PTC314.00	0.26m³ / 46kg / 2pcs	<b>538,00</b>	159x79 (62 1/2"x31")	PTC214.00	0.26m³ / 46kg / 2pcs	<b>538,00</b>

### ABOUT COMPACTOP: MUCH MORE THAN A MERE SURFACE

Gaber Compactops are made of high-pressure laminate, consisting of numerous layers of paper saturated with thermosetting resins and bonded through the combined action of heat and high pressure. The paper used on Compactop (around 70% of the complete composition) comes from production processes that conform with the FSC chain of custody; phenolic and melamine resins are all strictly water-based.

The result is a stable, non-reactive, homogenous, non-porous, antistatic, high-density product with a totally distinct physical and chemical profile from that of its constituent parts. Thanks to the heat and high-pressure treatment it they undergo, Gaber Compactops are exceptionally tough and resistant to scratches, abrasions, chemicals and heat, making them ideal for a wide range of contract applications. Tops come pre-bored for Gaber kit bases.

Gaber Compactops conform to EN 438/1. According to this norm, the most important characteristics of Gaber Compactops are: their resistance to bumps, scratches, and wear and tear; color-fastness; easy cleanability; suitable for contact with food and general hygiene.

UNI EN 438 is the reference standard for Compactop Gaber tops. This standard prescribes tolerances in the flatness of the product and on possible stains and other similar surface defects, for which the admissible size is based on a maximum contamination area equivalent to 1mm² / m² of laminate, concentrated in a single point or distributed in more points, proportional to the size of the sheet under inspection.

### MAINTENANCE & CLEANING

No specific maintenance other than normal cleaning is required. The compact, non porous surface can easily be cleaned and disinfected with hot water, steam and any common non-abrasive household detergents and disinfectants, as long as these are not highly alkaline. Just a couple of precautions are necessary: avoid using strong acids and bases and avoid wiping with highly abrasive substances or equipment.

### CHE COS'È IL COMPACTOP? MOLTO PIÙ DI UNA SEMPLICE SUPERFICIE

Il Compactop che Gaber utilizza per i propri tavoli è un laminato realizzato ad alta pressione, costituito da numerosi strati di carta impregnati con resine termoindurenti fenoliche e melaminiche, compattati attraverso l'azione combinata di calore ed alta pressione. Le carte utilizzate (circa il 70% della composizione dei piani) derivano da processi che seguono il protocollo della catena di custodia certificata FSC; le resine fenoliche e melaminiche sono tutte rigorosamente realizzate su base acquosa.

Il risultato è un prodotto stabile, non reattivo, omogeneo, non poroso, antistatico e di alta densità. Grazie al trattamento di alta temperatura e pressione cui è sottoposto, il Compactop è un materiale estremamente robusto: resistente a graffi, urti, abrasioni, sostanze chimiche e calore; caratteristiche che lo rendono il materiale ideale per una vasta gamma di applicazioni. I fissaggi dei piani Compactop sono già predisposti per i basamenti Gaber.

Il Compactop è conforme alla norma EN 438/1, secondo la quale, queste sono le principali caratteristiche di qualità di questo materiale: Resistente all'impatto, ai graffi e all'usura, stabile alla luce, facile da pulire, igienico, adatto al contatto con i cibi.

La UNI EN 438 è la norma di riferimento dei piani in Compactop Gaber. Tale normativa prescrive tolleranze nella planarità del prodotto e su possibili macchie e altri difetti superficiali simili, per i quali la dimensione ammissibile è basata su un'area di contaminazione massima equivalente a 1mm²/m² di laminato, concentrata in un unico punto o dispersa in più punti, proporzionale alla dimensione del foglio sottoposto a ispezione.

### MANUTENZIONE E PULIZIA

Il Compactop non richiede alcuna manutenzione particolare al di là della normale pulizia.

La sua superficie compatta e non porosa può essere facilmente pulita e disinfettata con acqua calda, vapore e tutti i tipi dei più comuni detergenti e disinfettanti per uso domestico, purché non alcalini. Sono necessarie solo poche precauzioni, quali l'evitare l'uso di acidi o basi forti, evitare di strofinare con sostanze o strumenti fortemente abrasivi.



# Special Compactop Surfaces

## 10



Flat black edge  
Bordo piatto nero

10 mm  
(0.39")

(min. 20pcs each code)  
(min. 20pcs per codice)

### Solid



244

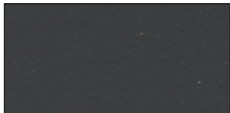

526



527



247

### Stone, Concrete effect

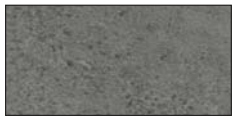

3192



3349



3276

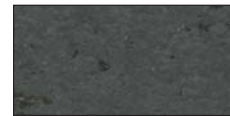

3329

### Wood effect



4529



4543



4587



4511

### Marble effect



5547







6075



6076



6089

	Sizes / Misure	Code / Codice		€
	Ø 60 (23 ½")	PTC501. __	0.700m <sup>3</sup> / 95kg / 20pcs	<b>198,00</b>
	Ø 68 (27")	PTC503. __	0.700m <sup>3</sup> / 120kg / 20pcs	<b>237,00</b>
	Ø 80 (31 ½")	PTC505. __	0.84m <sup>3</sup> / 185kg / 20pcs	<b>276,00</b>
	Ø 100 (39 ½")	PTC508. __	1.20m <sup>3</sup> / 285kg / 20pcs	<b>425,00</b>
	Ø 120 (47")	PTC509. __	1.20m <sup>3</sup> / 405kg / 20pcs	<b>592,00</b>
	Ø 140 (55")	PTC515. __	1.60m <sup>3</sup> / 535kg / 20pcs	<b>603,00</b>
	59x59 (23"x23")	PTC502. __	0.700m <sup>3</sup> / 115kg / 20pcs	<b>157,00</b>
	68x68 (27"x27")	PTC504. __	0.700m <sup>3</sup> / 155kg / 20pcs	<b>183,00</b>
	79x79 (31"x31")	PTC506. __	0.840m <sup>3</sup> / 195kg / 20pcs	<b>206,00</b>
	89x89 (35"x35")	PTC507. __	0.840m <sup>3</sup> / 245kg / 20pcs	<b>279,00</b>
	120x50 (47"x19 ½")	PTC510. __	0.84m <sup>3</sup> / 225kg / 20pcs	<b>295,00</b>
	140x70 (55"x27 ½")	PTC511. __	0.95m <sup>3</sup> / 355kg / 20pcs	<b>405,00</b>
	120x80 (47"x31 ½")	PTC512. __	0.84m <sup>3</sup> / 345kg / 20pcs	<b>389,00</b>
	159x79 (62 ½"x31")	PTC514. __	1.20m <sup>3</sup> / 455kg / 20pcs	<b>448,00</b>

#### ABOUT COMPACTOP: MUCH MORE THAN A MERE SURFACE

Gaber Compactops are made of high-pressure laminate, consisting of numerous layers of paper saturated with thermosetting resins and bonded through the combined action of heat and high pressure. The paper used on Compactop (around 70% of the complete composition) comes from production processes that conform with the FSC chain of custody; phenolic and melamine resins are all strictly water-based. The result is a stable, non-reactive, homogenous, non-porous, antistatic, high-density product with a totally distinct physical and chemical profile from that of its constituent parts. Thanks to the heat and high-pressure treatment it they undergo, Gaber Compactops are exceptionally tough and resistant to scratches, abrasions, chemicals and heat, making them ideal for a wide range of contract applications. Tops come pre-bored for Gaber kit bases. Gaber Compactops conform to EN 438/1. According to this norm, the most important characteristics of Gaber Compactops are: their resistance to bumps, scratches, and wear and tear; color-fastness; easy cleanability; suitable for contact with food and general hygiene. UNI EN 438 is the reference standard for Compactop Gaber tops. This standard prescribes tolerances in the flatness of the product and on possible stains and other similar surface defects, for which the admissible size is based on a maximum contamination area equivalent to 1mm<sup>2</sup> / m<sup>2</sup> of laminate, concentrated in a single point or distributed in more points, proportional to the size of the sheet under inspection.

#### MAINTENANCE & CLEANING

No specific maintenance other than normal cleaning is required. The compact, non porous surface can easily be cleaned and disinfected with hot water, steam and any common non-abrasive household detergents and disinfectants, as long as these are not highly alkaline. Just a couple of precautions are necessary: avoid using strong acids and bases and avoid wiping with highly abrasive substances or equipment.

#### CHE COS'È IL COMPACTOP? MOLTO PIÙ DI UNA SEMPLICE SUPERFICIE

Il Compactop che Gaber utilizza per i propri tavoli è un laminato realizzato ad alta pressione, costituito da numerosi strati di carta impregnati con resine termoindurenti fenoliche e melaminiche, compattati attraverso l'azione combinata di calore ed alta pressione. Le carte utilizzate (circa il 70% della composizione dei piani) derivano da processi che seguono il protocollo della catena di custodia certificata FSC; le resine fenoliche e melaminiche sono tutte rigorosamente realizzate su base acquosa. Il risultato è un prodotto stabile, non reattivo, omogeneo, non poroso, antistatico e di alta densità. Grazie al trattamento di alta temperatura e pressione cui è sottoposto, il Compactop è un materiale estremamente robusto: resistente a graffi, urti, abrasioni, sostanze chimiche e calore; caratteristiche che lo rendono il materiale ideale per una vasta gamma di applicazioni. I fissaggi dei piani Compactop sono già predisposti per i basamenti Gaber. Il Compactop è conforme alla norma EN 438/1, secondo la quale, queste sono le principali caratteristiche di qualità di questo materiale: Resistente all'impatto, ai graffi e all'usura, stabile alla luce, facile da pulire, igienico, adatto al contatto con i cibi.

La UNI EN 438 è la norma di riferimento dei piani in Compactop Gaber. Tale normativa prescrive tolleranze nella planarità del prodotto e su possibili macchie e altri difetti superficiali simili, per i quali la dimensione ammissibile è basata su un'area di contaminazione massima equivalente a 1mm<sup>2</sup>/m<sup>2</sup> di laminato, concentrata in un unico punto o dispersa in più punti, proporzionale alla dimensione del foglio sottoposto a ispezione.

#### MANUTENZIONE E PULIZIA

Il Compactop non richiede alcuna manutenzione particolare al di là della normale pulizia.

La sua superficie compatta e non porosa può essere facilmente pulita e disinfettata con acqua calda, vapore e tutti i tipi dei più comuni detergenti e disinfettanti per uso domestico, purché non alcalini. Sono necessarie solo poche precauzioni, quali l'evitare l'uso di acidi o basi forti, evitare di strofinare con sostanze o strumenti fortemente abrasivi.

# Special Compactop Surfaces

## Fenix

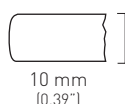

Flat black edge  
Bordo piatto nero

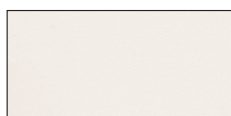

(min. 20pcs each code)  
(min. 20pcs per codice)

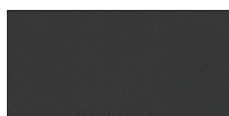

0029



0720

	Sizes / Misure	Code / Codice		€
	Ø 60 (23 1/2")	PTC401. __	0.70m <sup>3</sup> / 95kg / 20pcs	<b>237,00</b>
	Ø 68 (27")	PTC403. __	0.70m <sup>3</sup> / 120kg / 20pcs	<b>284,00</b>
	59x59 (23"x23")	PTC402. __	0.70m <sup>3</sup> / 115kg / 20pcs	<b>188,00</b>
	68x68 (27"x27")	PTC404. __	0.70m <sup>3</sup> / 155kg / 20pcs	<b>217,00</b>
	79x79 (31"x31")	PTC406. __	0.84m <sup>3</sup> / 195kg / 20pcs	<b>248,00</b>
	89x89 (35"x35")	PTC407. __	0.84m <sup>3</sup> / 245kg / 20pcs	<b>335,00</b>

### ABOUT FENIX COMPACTOP

Gaber's Fenix Compactop differ from standards as they are built with new generation materials on exposed coated surfaces, made using nanoparticles and acrylic resins. This coating avoid fingerprints on the material, make it soft-touch, heat-repairing, opaque and extremely resistant to bumps and scratches. In addition to this, the material is water repellent, hygienic, easy to clean and suitable for food-contact.

### MAINTENANCE & CLEANING

No specific maintenance other than normal cleaning is required. The compact, non porous surface can easily be cleaned and disinfected with a soft cloth dampened with hot water, steam and any common non-abrasive household detergents and disinfectants, as long as these are not highly alkaline. Just a couple of precautions are necessary: avoid using strong acids and bases and avoid wiping with highly abrasive substances or equipment.

### CHE COS'E' IL FENIX COMPACTOP

I piani Compactop Fenix di Gaber differiscono dagli standard in quanto prevedono l'utilizzo delle superfici esposte rivestite con materiali di nuova generazione, realizzati per mezzo dell'uso di nanoparticelle e resine acriliche. Tali rivestimenti rendono il materiale anti-impronta, morbido al tatto, termo-riparatore, opaco ed estremamente resistente ad urti e graffi. Oltre a ciò, il materiale è idrorepellente, igienico, resistente alle muffe, facile da pulire e adatto al contatto con alimenti.

### MANUTENZIONE E PULIZIA

Il Compactop non richiede alcuna manutenzione particolare al di là della normale pulizia.

La sua superficie compatta e non porosa può essere facilmente pulita e disinfettata con un panno umido, acqua calda, vapore e tutti i tipi dei più comuni detergenti e disinfettanti per uso domestico, purché non alcalini. Sono necessarie solo poche precauzioni, quali l'evitare l'uso di acidi o basi forti, evitare di strofinare con sostanze o strumenti fortemente abrasivi.

# Standard Laminated Surfaces

## 22



Bottom surfaces of our laminated tops are in white, black or dark grey colors.  
Il fondo del piano laminato può essere con colore bianco, nero o grigio antracite.



22 mm  
(0.86")



25 mm  
(0.98")







F W RN 00



10

For orders under 10no. surcharge 20€ each unit  
Per ordini inferiori ai 10pz + €20,00 ogni unità.

	Sizes / Misure	Code / Codice		€
	Ø 60 (23 1/2")	PTL101.__	0.054m <sup>3</sup> / 11kg / 2pcs	<b>133,00</b>
	Ø 70 (27 1/2")	PTL103.__	0.074m <sup>3</sup> / 13kg / 2pcs	<b>169,00</b>
	Ø 80 (31 1/2")	PTL105.__	0.090m <sup>3</sup> / 14kg / 2pcs	<b>236,00</b>
	Ø 90 (35 1/2")	PTL127.__	0.110m <sup>3</sup> / 16kg / 2pcs	<b>273,00</b>
	Ø 100 (39 1/2")	PTL108.__	0.200m <sup>3</sup> / 20kg / 2pcs	<b>386,00</b>
	Ø 120 (47")	PTL109.__	0.260m <sup>3</sup> / 27kg / 2pcs	<b>450,00</b>
	Ø 140 (55")	PTL115.__	0.300m <sup>3</sup> / 33kg / 2pcs	<b>544,00</b>
	60x60 (23 1/2"X23 1/2")	PTL102.__	0.054m <sup>3</sup> / 13kg / 2pcs	<b>122,00</b>
	70x70 (27 1/2"X27 1/2")	PTL104.__	0.074m <sup>3</sup> / 19kg / 2pcs	<b>133,00</b>
	80x80 (31 1/2"X31 1/2")	PTL106.__	0.090m <sup>3</sup> / 24kg / 2pcs	<b>150,00</b>
	90x90 (35 1/2"X35 1/2")	PTL107.__	0.110m <sup>3</sup> / 27kg / 2pcs	<b>184,00</b>
	100x100 (39 1/2"X39 1/2")	PTL128.__	0.200m <sup>3</sup> / 28kg / 2pcs	<b>282,00</b>
	120x50 (47"X19 1/2")	PTL110.__	0.110m <sup>3</sup> / 27kg / 2pcs	<b>188,00</b>
	120x80 (47"X31 1/2")	PTL112.__	0.200m <sup>3</sup> / 30kg / 2pcs	<b>198,00</b>
	140x70 (55"X27 1/2")	PTL111.__	0.200m <sup>3</sup> / 34kg / 2pcs	<b>219,00</b>
	160x80 (63"X31 1/2")	PTL114.__	0.260m <sup>3</sup> / 36kg / 2pcs	<b>335,00</b>

### ABOUT LAMINATED TABLE TOPS

Gaber's laminate table tops are composed of a high-pressure decorative laminate layer, with a recycled-wood chipboard core and ABS edging. Gaber's support materials are E1 according to tests stipulated by the European standards EN717 and EN120 regarding formaldehyde emission. Laminate tops come ready for Gaber kit bases.

The result is homogeneous, static, lightweight and highly customizable in terms of shapes and finishes.

Our laminate tops are manufactured according to the following European Standards related to fire reaction: EN 13501-1:2009 B -s2, d0.

### MAINTENANCE & CLEANING

Gaber laminated table tops do not require any special maintenance beyond normal cleaning.

Laminated surfaces can be easily cleaned with a soft cloth dampened with water, even with cleaning agents, but not alkaline and generally aggressive. Avoid the use of strong acids or bases, avoid wiping with abrasive substances or equipment.

### COSA SONO I PIANI DEI TAVOLI IN LAMINATO?

I ripiani laminati che Gaber utilizza per i propri tavoli sono composti da uno strato di laminato decorativo ad alta pressione, supportato da un pannello di truciolare; quest'ultimo realizzato con i materiali di scarto delle normali lavorazioni del legno. I piani sono bordati con bordo in Abs. La tipologia di supporto utilizzato da Gaber per i propri piani è di classe E1 secondo i test espressi dalle normative europee EN717 e EN120 in materia di emissione di formaldeide. I fissaggi dei ripiani in Laminato sono già predisposti per i basamenti Gaber.

Il risultato è un prodotto omogeneo, antistatico, leggero e facilmente personalizzabile in forme e finiture.

I nostri piani in laminato sono realizzati secondo la normativa europea di reazione al fuoco EN 13501-1:2009 B -s2, d0.

### MANUTENZIONE E PULIZIA

I piani Laminati di Gaber non richiedono alcuna manutenzione particolare al di là della normale pulizia.

La sua superficie può essere facilmente pulita con un panno morbido imbevuto di acqua, anche con detersivi per uso domestico, purché non alcalini ed in genere aggressivi. Evitare l'uso di acidi o basi forti, evitare di strofinare con sostanze o strumenti abrasivi.

# Standard Laminated Surfaces

## 50





Bottom surfaces of our laminated tops are in white, black or dark grey colors. Il fondo del piano laminato può essere con colore bianco, nero o grigio antracite.

50 mm (1.96")  
20 mm  
42 mm



F W RN 00 10

For orders under 10no. surcharge 20€ each unit  
Per ordini inferiori ai 10pz + €20,00 ogni unità.

	Sizes / Misure	Code / Codice		€
	60x60 (23 1/2"X23 1/2")	PTL202.__	0.054m <sup>3</sup> / 7kg / 1pcs	<b>118,00</b>
	70x70 (27 1/2"X27 1/2")	PTL204.__	0.074m <sup>3</sup> / 9kg / 1pcs	<b>188,00</b>
	80x80 (31 1/2"X31 1/2")	PTL206.__	0.090m <sup>3</sup> / 13kg / 1pcs	<b>248,00</b>
	90x90 (35 1/2"X35 1/2")	PTL207.__	0.110m <sup>3</sup> / 15kg / 1pcs	<b>268,00</b>
	100x100 (39 1/2"X39 1/2")	PTL228.__	0.200m <sup>3</sup> / 16kg / 1pcs	<b>319,00</b>
	120x80 (47"X31 1/2")	PTL212.__	0.200m <sup>3</sup> / 17kg / 1pcs	<b>270,00</b>

### ABOUT LAMINATED TABLE TOPS

Gaber's laminate table tops are composed of a high-pressure decorative laminate layer, with a recycled-wood chipboard core and ABS edging. Gaber's support materials are E1 according to tests stipulated by the European standards EN717 and EN120 regarding formaldehyde emission. Laminate tops come ready for Gaber kit bases.

The result is homogeneous, static, lightweight and highly customizable in terms of shapes and finishes.

Our laminate tops are manufactures according the following European Standards related to fire reaction: EN 13501-1:2009 B -s2, d0.

### MAINTENANCE & CLEANING

Gaber laminated table tops do not require any special maintenance beyond normal cleaning.

Laminated surfaces can be easily cleaned with a soft cloth dampened with water, even with cleaning agents, but not alkaline and generally aggressive. Avoid the use of strong acids or bases, avoid wiping with abrasive substances or equipment.

### COSA SONO I PIANI DEI TAVOLI IN LAMINATO?

I ripiani laminati che Gaber utilizza per i propri tavoli sono composti da uno strato di laminato decorativo ad alta pressione, supportato da un pannello di truciolare; quest'ultimo realizzato con i materiali di scarto delle normali lavorazioni del legno. I piani sono bordati con bordo in Abs. La tipologia di supporto utilizzato da Gaber per i propri piani è di classe E1 secondo i test espressi dalle normative europee EN717 e EN120 in materia di emissione di formaldeide. I fissaggi dei ripiani in Laminato sono già predisposti per i basamenti Gaber.

Il risultato è un prodotto omogeneo, antistatico, leggero e facilmente personalizzabile in forme e finiture.

I nostri piani in laminato sono realizzati secondo la normativa europea di reazione al fuoco EN 13501-1:2009 B -s2, d0.

### MANUTENZIONE E PULIZIA

I piani Laminati di Gaber non richiedono alcuna manutenzione particolare al di là della normale pulizia.

La sua superficie può essere facilmente pulita con un panno morbido imbevuto di acqua, anche con detersivi per uso domestico, purché non alcalini ed in genere aggressivi. Evitare l'uso di acidi o basi forti, evitare di strofinare con sostanze o strumenti abrasivi.

# Special Laminated Surfaces

## Wood Effect 25

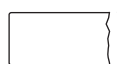

 25 mm (0.98") (min. 20pcs each code) (min. 20pcs per codice)

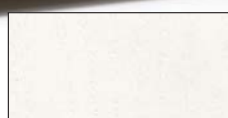

B01



X41



61M





V32



WG8

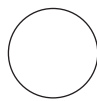

WG9

	Sizes / Misura	Code / Codice		€
	Ø 60 (23 1/2")	PTL301. __	0.700m <sup>3</sup> / 85kg / 20pcs	<b>152,00</b>
	Ø 70 (27 1/2")	PTL303. __	0.700m <sup>3</sup> / 105kg / 20pcs	<b>192,00</b>
	Ø 80 (31 1/2")	PTL305. __	0.840m <sup>3</sup> / 125kg / 20pcs	<b>273,00</b>
	Ø 90 (35 1/2")	PTL327. __	0.840m <sup>3</sup> / 155kg / 20pcs	<b>310,00</b>
	Ø 100 (39 1/2")	PTL308. __	1.200m <sup>3</sup> / 190kg / 20pcs	<b>423,00</b>
	Ø 120 (47")	PTL309. __	1.200m <sup>3</sup> / 270kg / 20pcs	<b>488,00</b>
	Ø 140 (55")	PTL315. __	1.600m <sup>3</sup> / 325kg / 20pcs	<b>581,00</b>
	60x60 (23 1/2" X 23 1/2")	PTL302. __	0.700m <sup>3</sup> / 95kg / 20pcs	<b>141,00</b>
	70x70 (27 1/2" X 27 1/2")	PTL304. __	0.700m <sup>3</sup> / 125kg / 20pcs	<b>153,00</b>
	80x80 (31 1/2" X 31 1/2")	PTL306. __	0.840m <sup>3</sup> / 160kg / 20pcs	<b>172,00</b>
	90x90 (35 1/2" X 35 1/2")	PTL307. __	0.840m <sup>3</sup> / 195kg / 20pcs	<b>209,00</b>
	100x100 (39 1/2" X 39 1/2")	PTL328. __	1.200m <sup>3</sup> / 235kg / 20pcs	<b>319,00</b>
	120x50 (47" X 19 1/2")	PTL310. __	0.840m <sup>3</sup> / 155kg / 20pcs	<b>225,00</b>
	120x80 (47" X 31 1/2")	PTL312. __	0.840m <sup>3</sup> / 235kg / 20pcs	<b>236,00</b>
	140x70 (55" X 27 1/2")	PTL311. __	0.950m <sup>3</sup> / 240kg / 20pcs	<b>256,00</b>
	160x80 (63" X 31 1/2")	PTL314. __	1.200m <sup>3</sup> / 300kg / 20pcs	<b>372,00</b>

### ABOUT LAMINATED TABLE TOPS

Gaber's laminate table tops are composed of a high-pressure decorative laminate layer, with a recycled-wood chipboard core and ABS edging. Gaber's support materials are E1 according to tests stipulated by the European standards EN717 and EN120 regarding formaldehyde emission. Laminate tops come ready for Gaber kit bases.

The result is homogeneous, static, lightweight and highly customizable in terms of shapes and finishes.

To optimize the production process, sizes may vary in tolerance  $\pm 5$ mm.

### MAINTENANCE & CLEANING

Gaber laminated table tops do not require any special maintenance beyond normal cleaning.

Laminated surfaces can be easily cleaned with a soft cloth dampened with water, even with cleaning agents, but not alkaline and generally aggressive. Avoid the use of strong acids or bases, avoid wiping with abrasive substances or equipment.

### COSA SONO I PIANI DEI TAVOLI IN LAMINATO?

I ripiani laminati che Gaber utilizza per i propri tavoli sono composti da uno strato di laminato decorativo ad alta pressione, supportato da un pannello di truciolare; quest'ultimo realizzato con i materiali di scarto delle normali lavorazioni del legno. I piani sono bordati con bordo in Abs. La tipologia di supporto utilizzato da Gaber per i propri piani è di classe E1 secondo i test espressi dalle normative europee EN717 e EN120 in materia di emissione di formaldeide. I fissaggi dei ripiani in Laminato sono già predisposti per i basamenti Gaber.

Il risultato è un prodotto omogeneo, antistatico, leggero e facilmente personalizzabile in forme e finiture.

Ad ottimizzazione delle lavorazioni, le dimensioni possono variare nella tolleranza di  $\pm 5$ mm.

### MANUTENZIONE E PULIZIA

I piani Laminati di Gaber non richiedono alcuna manutenzione particolare al di là della normale pulizia.

La sua superficie può essere facilmente pulita con un panno morbido imbevuto di acqua, anche con detersivi per uso domestico, purché non alcalini ed in genere aggressivi. Evitare l'uso di acidi o basi forti, evitare di strofinare con sostanze o strumenti abrasivi.

# Special Laminated Surfaces

## Fenix 25



25 mm (0.98") (min. 20pcs each code) (min. 20pcs per codice)

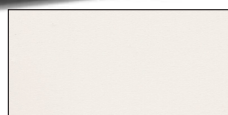

0029

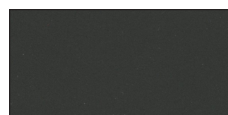

720

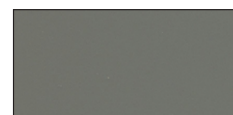

718







2630

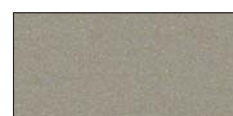

2629



2628

	Sizes / Misure	Code / Codice		€
	Ø 60 (23 1/2")	PTL401.__	0.700m <sup>3</sup> / 85kg / 20pcs	<b>152,00</b>
	Ø 70 (27 1/2")	PTL403.__	0.700m <sup>3</sup> / 105kg / 20pcs	<b>192,00</b>
	Ø 80 (31 1/2")	PTL405.__	0.840m <sup>3</sup> / 125kg / 20pcs	<b>273,00</b>
	Ø 90 (35 1/2")	PTL427.__	0.840m <sup>3</sup> / 155kg / 20pcs	<b>310,00</b>
	Ø 100 (39 1/2")	PTL408.__	1.200m <sup>3</sup> / 190kg / 20pcs	<b>423,00</b>
	Ø 120 (47")	PTL409.__	1.200m <sup>3</sup> / 270kg / 20pcs	<b>488,00</b>
	Ø 140 (55")	PTL415.__	1.600m <sup>3</sup> / 325kg / 20pcs	<b>581,00</b>
	60x60 (23 1/2"X23 1/2")	PTL402.__	0.700m <sup>3</sup> / 95kg / 20pcs	<b>141,00</b>
	70x70 (27 1/2"X27 1/2")	PTL404.__	0.700m <sup>3</sup> / 125kg / 20pcs	<b>153,00</b>
	80x80 (31 1/2"X31 1/2")	PTL406.__	0.840m <sup>3</sup> / 160kg / 20pcs	<b>172,00</b>
	90x90 (35 1/2"X35 1/2")	PTL407.__	0.840m <sup>3</sup> / 195kg / 20pcs	<b>209,00</b>
	100x100 (39 1/2"X39 1/2")	PTL428.__	1.200m <sup>3</sup> / 235kg / 20pcs	<b>319,00</b>
	120x50 (47"X19 1/2")	PTL410.__	0.840m <sup>3</sup> / 155kg / 20pcs	<b>225,00</b>
	120x80 (47"X31 1/2")	PTL412.__	0.840m <sup>3</sup> / 235kg / 20pcs	<b>236,00</b>
	140x70 (55"X27 1/2")	PTL411.__	0.950m <sup>3</sup> / 240kg / 20pcs	<b>256,00</b>
	160x80 (63"X31 1/2")	PTL414.__	1.200m <sup>3</sup> / 300kg / 20pcs	<b>372,00</b>

### ABOUT FENIX LAMINATED TABLE TOPS

Gaber's Fenix laminated table tops are composed of a decorative Fenix laminate layer, with a recycled-wood chipboard core. Tops utilize ABS edging, made using nanoparticles and acrylic resins. This coating avoids fingerprints on the material, makes it soft-touch, heat-repairing, opaque and extremely resistant to bumps and scratches. In addition to this, the material is water repellent, hygienic, easy to clean and suitable for food-contact. Gaber's support materials are E1 according to tests stipulated by the European standards EN717 and EN120 regarding formaldehyde emission. Laminate tops come ready for Gaber kit bases. To optimize the production process, sizes may vary in tolerance ±5mm.

### MAINTENANCE & CLEANING

Gaber laminated table tops do not require any special maintenance beyond normal cleaning.

Laminated surfaces can be easily cleaned with a soft cloth dampened with water, even with cleaning agents, but not alkaline and generally aggressive. Avoid the use of strong acids or bases, avoid wiping with abrasive substances or equipment.

### CHE COSA SONO I PIANI DEI TAVOLI IN LAMINATO FENIX?

I ripiani laminati che Gaber utilizza per i propri tavoli sono composti da uno strato di laminato Fenix decorativo, supportato da un pannello truciolare; quest'ultimo realizzato con i materiali di scarto delle normali lavorazioni del legno. I piani sono bordati in ABS, realizzato per mezzo dell'uso di nanoparticelle e resine acriliche. Tali rivestimenti rendono il materiale anti-impronta, morbido al tatto, termoriparatore, opaco ed estremamente resistente ad urti e graffi. Oltre a ciò il materiale è idrorepellente, igienico, resistente alle muffe, facile da pulire e adatto al contatto con alimenti. La tipologia di supporto utilizzato da Gaber per i propri piani è di classe E1 secondo i test espressi dalle normative europee EN717 e EN120 in materia di emissione di formaldeide. I fissaggi dei ripiani in laminato sono già predisposti per i basamenti Gaber. Ad ottimizzazione delle lavorazioni, le dimensioni possono variare nella tolleranza di ±5mm.

### MANUTENZIONE E PULIZIA



I piani laminati di Gaber non richiedono alcuna manutenzione particolare al di là della normale pulizia.

La sua superficie può essere facilmente pulita con un panno morbido imbevuto di acqua, anche con detersivi per uso domestico, purché non alcalini ed in genere aggressivi. Evitare l'uso di acidi o basi forti, evitare di strofinare con sostanze o strumenti abrasivi.

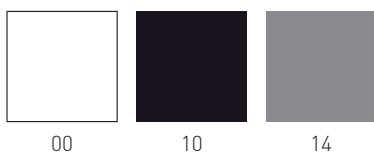
# Iron Surfaces



00 10 14

	Sizes / Misure	Code / Codice		€
	60x60 (23 1/2" X 23 1/2")	PTI102._	0.054m <sup>3</sup> / 16.4kg / 2pcs	<b>223,00</b>
	70x70 (27 1/2" X 27 1/2")	PTI104._	0.074m <sup>3</sup> / 21.6kg / 2pcs	<b>234,00</b>
	80x80 (31 1/2" X 31 1/2")	PTI106._	0.090m <sup>3</sup> / 22kg / 2pcs	<b>259,00</b>
	120x80 (47" X 31 1/2")	PTI112._	0.20m <sup>3</sup> / 31.2kg / 2pcs	<b>544,00</b>

## ABOUT IRON TABLE TOPS

Gaber's Iron table tops are made of composite materials: a non-deformable water-repellent multilayer wood-based core, covered in steel. The slim line result is elegant, stylish and practical. Iron tops come pre-bored for Gaber kit bases. These tough materials make iron tops suitable for indoor as well as outdoor use.

## MAINTENANCE & CLEANING

Gaber's Iron table tops do not require any special maintenance beyond normal cleaning.

Its surface can be easily cleaned with a soft cloth dampened with water, even with household cleaning detergent, provided they are not alkaline and generally aggressive. Avoid the use of strong acids or bases, avoid rubbing with abrasive substances or devices.

## COSA SONO I PIANI DEI TAVOLI IRON?

I sistemi Iron che Gaber utilizza per i propri piani dei tavoli sono realizzati da materiali compositi: il cuore del sistema è realizzato con un materiale multistrato, a base legnosa, resistente all'umidità, di grande stabilità. Il rivestimento in acciaio e lo spessore contenuto rendono il prodotto elegante, raffinato e pratico. I fissaggi dei piani Iron sono già predisposti per i basamenti Gaber. Le finiture disponibili lo rendono adatto anche all'uso per outdoor, grazie all'ottimale resistenza agli agenti atmosferici.

## MANUTENZIONE E PULIZIA



I piani Iron di Gaber non richiedono alcuna manutenzione particolare al di là della normale pulizia.

La sua superficie può essere facilmente pulita con un panno morbido imbevuto di acqua, anche con detersivi per uso domestico, purché non alcalini ed in genere aggressivi. Evitare l'uso di acidi o basi forti, evitare di strofinare con sostanze o strumenti abrasivi.

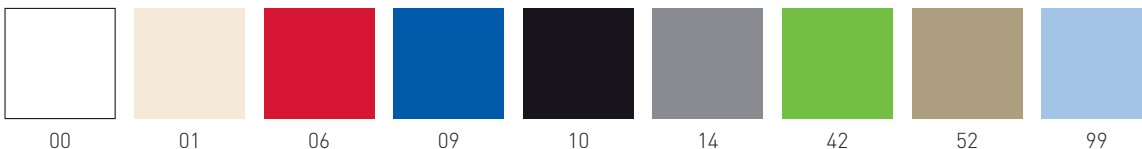

# Techno Polymer Table Tops



	Sizes / Misure	Code / Codice		€
	Ø 60 (23 ½")	PTT04_	0.054m³ / 4kg / 1pcs	<b>96,00</b>
	Ø 72 (28 ½")	PTT03_	0.074m³ / 4.7kg / 1pcs	<b>122,00</b>
	60x60 (23 ½"X23 ½")	PTT20_	0.054m³ / 4.8kg / 1pcs	<b>122,00</b>
	72x72 (28 ½"X28 ½")	PTT06_	0.074m³ / 6kg / 1pcs	<b>143,00</b>
	80x80 (31 ½"X31 ½")	PTT23_	0.090m³ / 8.6kg / 1pcs	<b>164,00</b>

## ABOUT TECHNO POLYMER TABLE-TOPS

The Techno Polymer Compounds Gaber uses on its table tops have high structural, heat and abrasion resistance. Gaber's technopolymer table tops are practical, shock-resistant, colorful and inexpensive.

Gaber technopolymers are non-toxic, stain-resistant, antistatic and UV-resistant and consequently have excellent resistance to atmospheric agents. All these materials are recyclable in the full respect of our Natural Environment. Gaber produces plastic injected materials without added chemicals and, as far as possible, recycled pre-used technopolymers are sourced as a base raw material. Technopolymer table top colors perfectly match the colors of Gaber's seating collection.

## MAINTENANCE & CLEANING

The plastic surfaces of Gaber products can generally be cleaned with a cloth and warm water. For the most persistent stains, a small amount of liquid soap diluted in water may be used. Do not use acetone, trichloroethylene, ammonia, alcoholic substances and detergents that contain even just a small amount of these substances. We also recommend avoiding all types of abrasive and solvent substances or rough sponges.

## COME SONO FATTI I RIPIANI IN TECNOPOLIMERO?

I piani in Tecnopolimero utilizzati da Gaber per i propri tavoli sono realizzati per mezzo del processo di iniezione plastica. I piani così realizzati sono pratici, resistenti agli urti, colorati ed economici. I compound di tecnopolimeri utilizzati da Gaber nella realizzazione dei propri prodotti sono caratterizzati da un'elevata resistenza strutturale, termica e all'abrasione. Il tecnopolimero è atossico, antimacchia, antistatico e anti-uv: qualità che lo rendono ottimamente resistente agli agenti atmosferici. I tecnopolimeri utilizzati da Gaber sono integralmente riciclabili, nel pieno rispetto del nostro Ambiente Naturale. Gaber produce articoli termoplastici senza additivi chimici e, ove possibile, vengono utilizzati tecnopolimeri riciclati derivanti da post-consumo. I colori dei ripiani dei tavoli corrispondono ai colori della vasta collezione di sedute Gaber.

## MANUTENZIONE E PULIZIA

Le superfici in tecnopolimero dei piani dei tavoli Gaber possono essere pulite con un panno umido e soffice imbevuto in acqua. Per le macchie più ostinate è possibile diluire in acqua del sapone neutro liquido con moderazione. Non utilizzare acetone, trielina, ammoniaca, sostanze alcoliche o detersivi che contengano anche piccole quantità di tali detersivi. Non utilizzare a contatto con il prodotto sostanze abrasive o solventi, strumenti di pulizia ruvidi.

# TABLE BASES Collection

# ARKET 3 BASE

H49-H73-H109 3 spur aluminum casted base, column made in aluminum extruded tube, aluminum cross and adjustable feet. Basamento per tavolo H49-H73-H109 con 3 razze e crociera in alluminio pressofuso, colonna in alluminio estruso. Piedini regolabili.

Top max dimensions / Massima dimensione piano

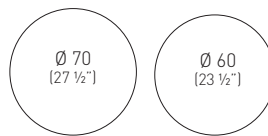

Available table tops / Piani tavolo disponibili

compactop laminated



Frame Color / Colore Struttura

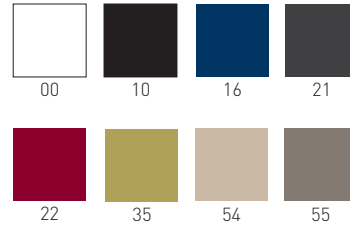

H49	BAK3B.____		0.055m³ / 3.5kg / 1pcs	€ <b>188,00</b>
H73	BAK3.____		0.055m³ / 4.0kg / 1pcs	€ <b>200,00</b>
H109	BAK3A.____		0.085m³ / 4.2kg / 1pcs	€ <b>243,00</b>

Minimum order 20 pcs each code, unless combined with Gaber table tops. Ordine minimo 20 pezzi per codice, se non abbinato a piani Gaber.

# ARKET 4 BASE

H49-H73-H109 4 spur aluminum casted base, column made in aluminum extruded tube, aluminum cross and adjustable feet. Basamento per tavolo H49-H73-H109 con 4 razze e crociera in alluminio pressofuso, colonna in alluminio estruso. Piedini regolabili.

Top max dimensions / Massima dimensione piano

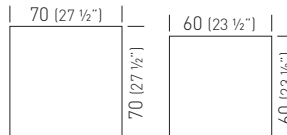

Available table tops / Piani tavolo disponibili

compactop laminated

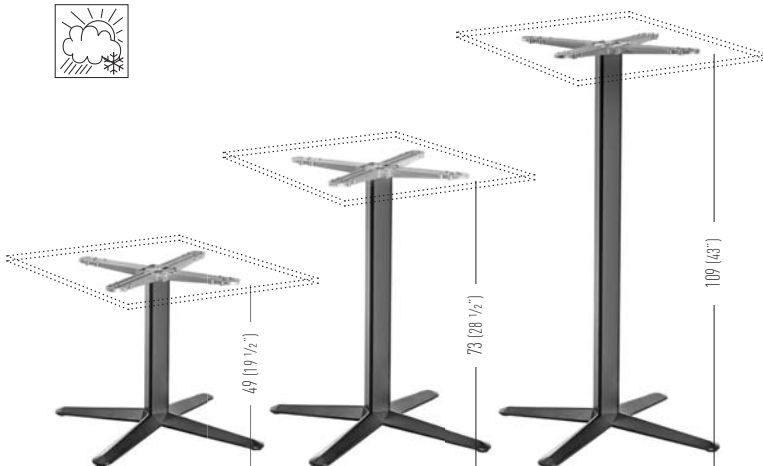

Frame Color / Colore Struttura

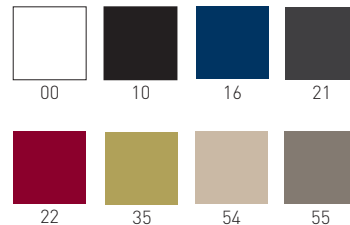

H49	BAK4B.____		0.055m³ / 4.2kg / 1pcs	€ <b>198,00</b>
H73	BAK4.____		0.055m³ / 4.5kg / 1pcs	€ <b>208,00</b>
H109	BAK4A.____		0.085m³ / 4.8kg / 1pcs	€ <b>257,00</b>

Minimum order 20 pcs each code, unless combined with Gaber table tops. Ordine minimo 20 pezzi per codice, se non abbinato a piani Gaber.

# ARKET PLUS

H73 3 spur metal-technopolymer co-injected table base, aluminum column and cross, flip-top mechanism. Base per tavolo pieghevole H73 a tre razze in metallo sovrastampato con tecnopolimero, colonna e crociera in alluminio.

Top max dimensions / Massima dimensione piano

Available table tops / Piani tavolo disponibili

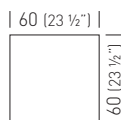
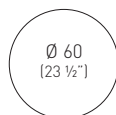

compactop laminated

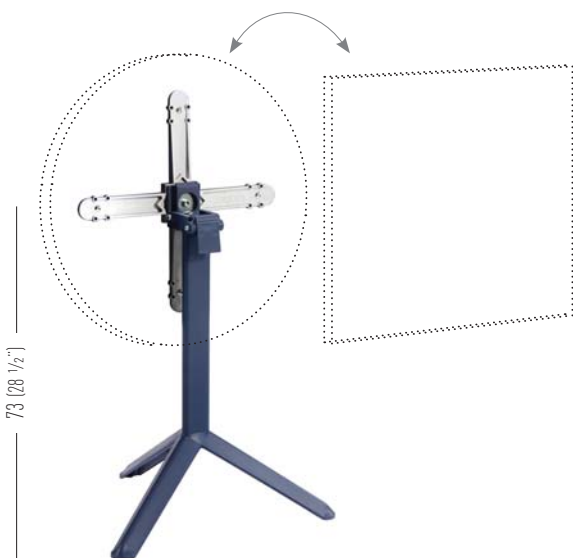

Frame Color / Colore Struttura

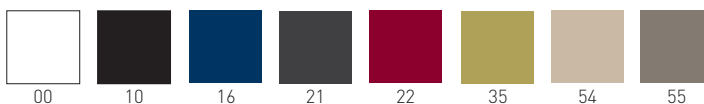

BAKP\_

0.12m<sup>3</sup> / 5.5kg / 1pc

€ 225,00

# BG3K

H73 3-spur metal-technopolymer co-injected table base, Ø 80mm anodized aluminum column with cross. Base per tavolo H73 a tre razze in metallo sovrastampato con tecnopolimero, colonna in alluminio anodizzato Ø 80mm, crociera.

Top max dimensions / Massima dimensione piano

Available table tops / Piani tavolo disponibili

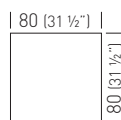
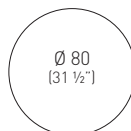

compactop laminated iron

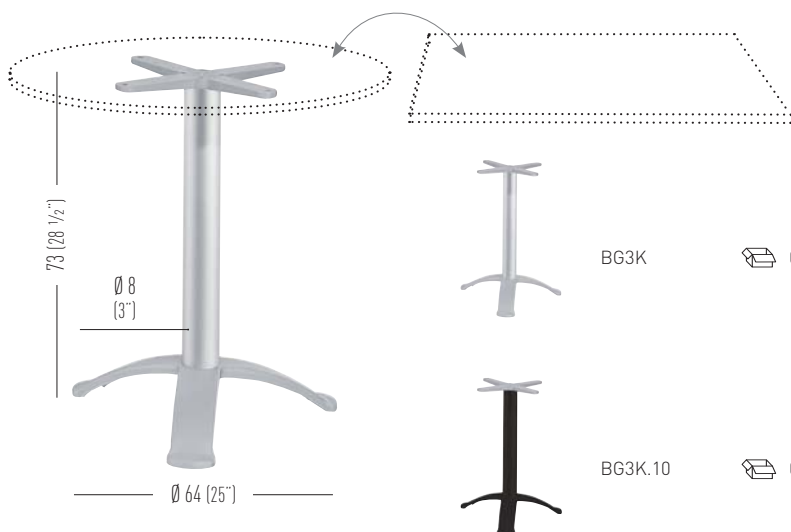

BG3K

0.07m<sup>3</sup> / 19.6kg / 2pcs

€ 186,00

BG3K.10

0.07m<sup>3</sup> / 19.6kg / 2pcs

€ 206,00

# BGA3K

H115 3-spur metal-technopolymer co-injected table base, Ø 80mm anodized aluminum column with cross.  
Base per tavolo H115 a tre razze in metallo sovrastampato con tecnopolimero, colonna in alluminio anodizzato Ø 80mm, crociera.

Top max dimensions / Massima dimensione piano

Available table tops / Piani tavolo disponibili

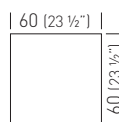
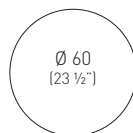

compactop  
laminated  
iron

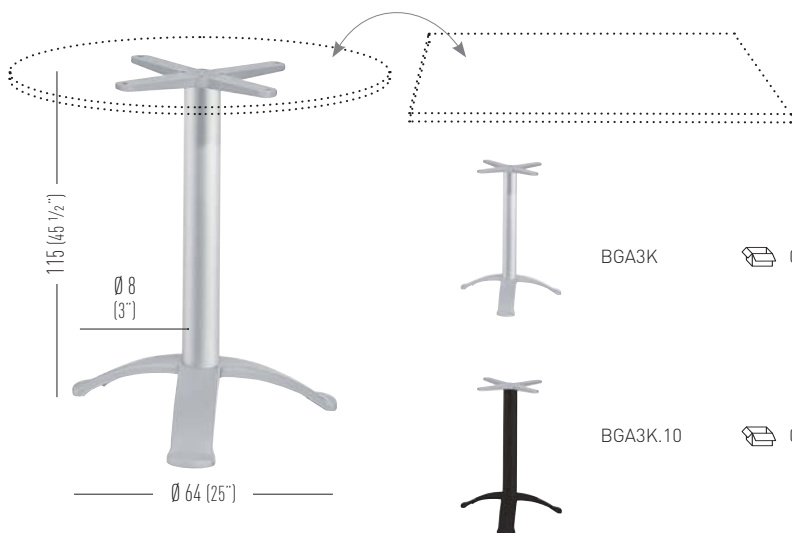

BGA3K 0.12m³ / 21,6kg / 2pcs € **251,00**

BGA3K.10 0.12m³ / 21,6kg / 2pcs € **276,00**

# BPG3K

H73 3-spur metal-technopolymer co-injected table base, Ø 60mm anodized aluminum column with cross.  
Base per tavolo H73 a tre razze in metallo sovrastampato con tecnopolimero, colonna in alluminio anodizzato Ø 60mm, crociera.

Top max dimensions / Massima dimensione piano

Available table tops / Piani tavolo disponibili

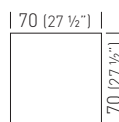

compactop  
laminated  
iron

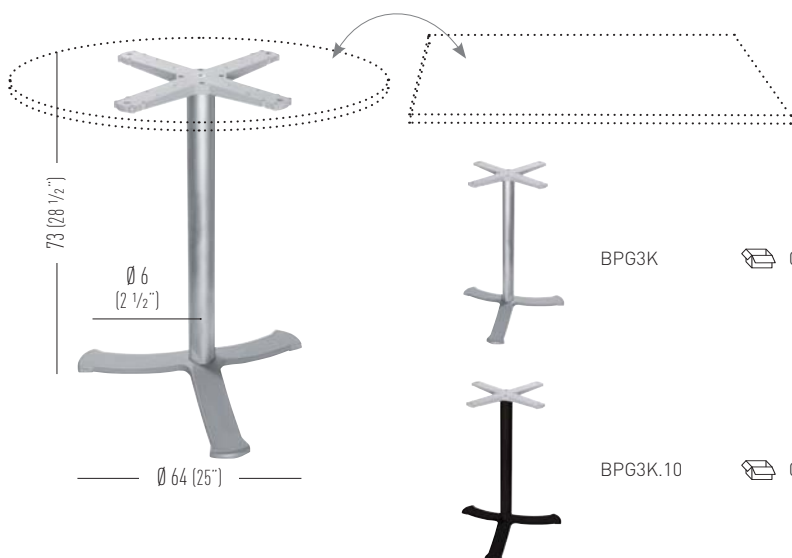

BPG3K 0.07m³ / 14.20kg / 2pcs € **186,00**

BPG3K.10 0.07m³ / 14.20kg / 2pcs € **206,00**

# BG3L

H73 3-spur metal-technopolymer co-injected table base, Ø 80mm anodized aluminum column with cross.  
Base per tavolo H73 a tre razze in metallo sovrastampato con tecnopolimero, colonna in alluminio anodizzato Ø 80mm, crociera.

Top max dimensions / Massima dimensione piano

Available table tops / Piani tavolo disponibili

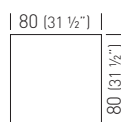
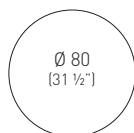

compactop  
laminated  
iron

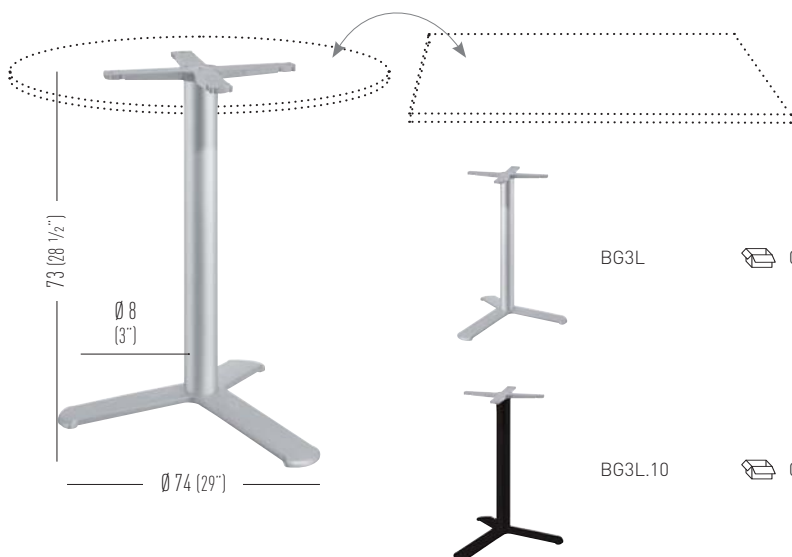

BG3L  0.08m<sup>3</sup> / 11kg / 1pcs € **186,00**

BG3L.10  0.08m<sup>3</sup> / 11kg / 1pcs € **206,00**

# BGA3L

H110 3-spur metal-technopolymer co-injected table base, Ø 80mm anodized aluminum column with cross.  
Base per tavolo H110 a tre razze in metallo sovrastampato con tecnopolimero, colonna in alluminio anodizzato Ø 80mm, crociera.

Top max dimensions / Massima dimensione piano

Available table tops / Piani tavolo disponibili

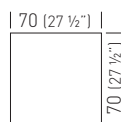
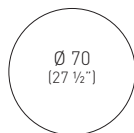

compactop  
laminated  
iron

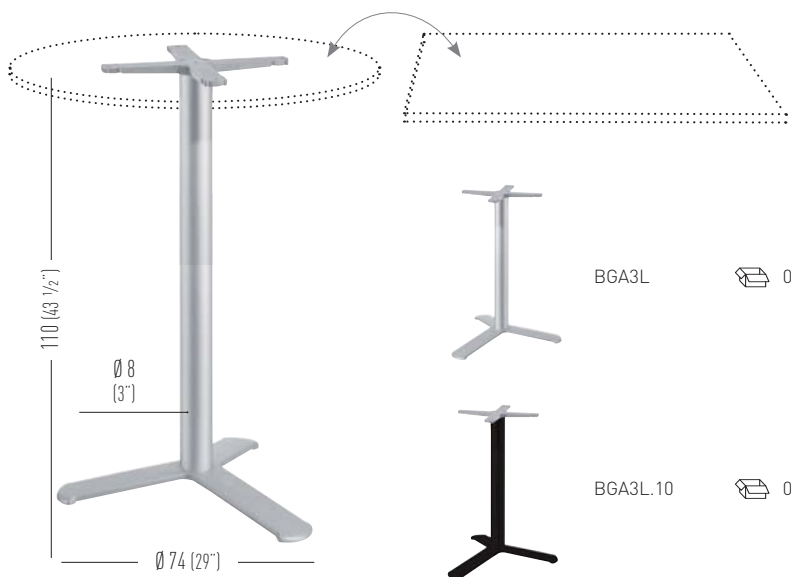

BGA3L  0.12m<sup>3</sup> / 23.6kg / 2pcs € **251,00**

BGA3L.10  0.12m<sup>3</sup> / 23.6kg / 2pcs € **276,00**

# BG4K

H73 4-spur metal-technopolymer co-injected table base, Ø 80mm anodized aluminum column with cross.  
 Base per tavolo H73 a quattro razze in metallo sovrastampato con tecnopolimero, colonna in alluminio anodizzato Ø 80mm, crociera.

Top max dimensions / Massima dimensione piano

Available table tops / Piani tavolo disponibili

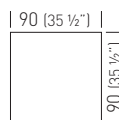
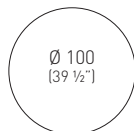

compactop  
laminated  
iron

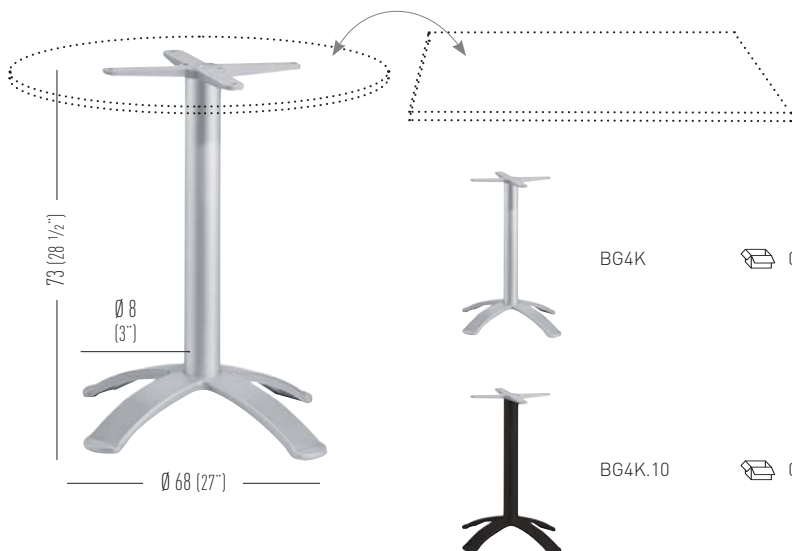

BG4K 0.07m³ / 25kg / 2pcs € **202,00**

BG4K.10 0.07m³ / 25kg / 2pcs € **220,00**

# BGA4K

H115 4-spur metal-technopolymer co-injected table base, Ø 80mm anodized aluminum column with cross.  
 Base per tavolo H115 a quattro razze in metallo sovrastampato con tecnopolimero, colonna in alluminio anodizzato Ø 80mm, crociera.

Top max dimensions / Massima dimensione piano

Available table tops / Piani tavolo disponibili

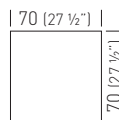
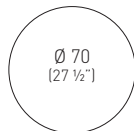

compactop  
laminated  
iron

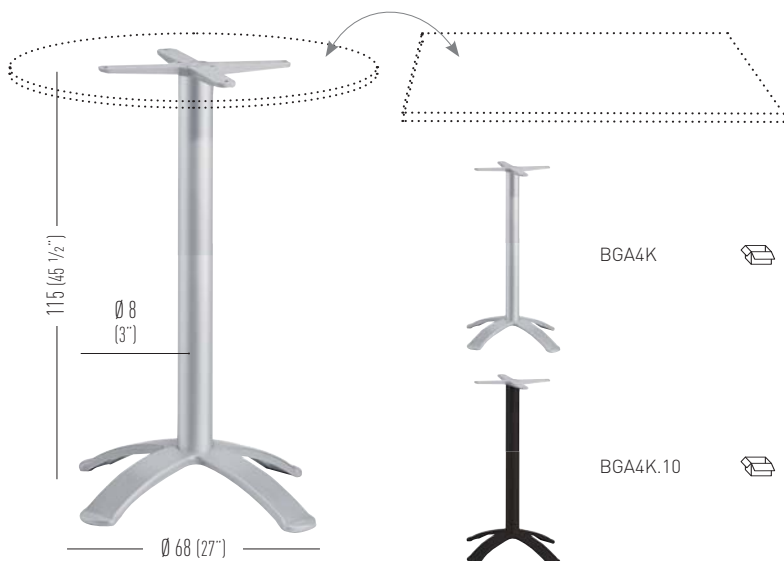

BGA4K 0.11m³ / 26.60kg / 2pcs € **284,00**

BGA4K.10 0.11m³ / 26.60kg / 2pcs € **310,00**

# BG4J

H73 4-spur metal-technopolymer co-injected table base, 80x80mm anodized aluminum column with cross. Base per tavolo H73 a quattro razze in metallo sovrastampato con tecnopolimero, colonna in alluminio anodizzato 80x80mm, crociera.

Top max dimensions / Massima dimensione piano

Available table tops / Piani tavolo disponibili

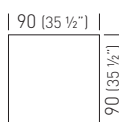
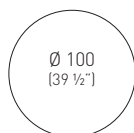

compactop  
laminated  
iron

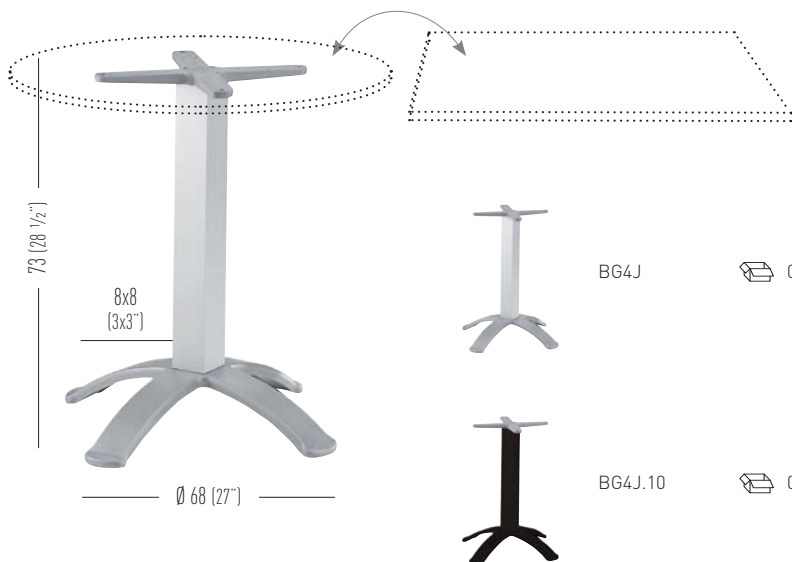

BG4J  0.10m<sup>3</sup> / 25.6kg / 2pcs € **211,00**

BG4J.10  0.10m<sup>3</sup> / 25.6kg / 2pcs € **233,00**

# BGPK

H73 4-spur metal-technopolymer co-injected table base, Ø 80mm anodized aluminum column with flip-top mechanism. Base per tavolo pieghevole H73 a quattro razze in metallo sovrastampato con tecnopolimero, colonna in alluminio anodizzato Ø 80mm.

Top max dimensions / Massima dimensione piano

Available table tops / Piani tavolo disponibili

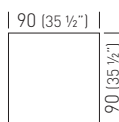
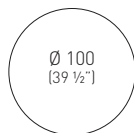

compactop  
laminated  
iron

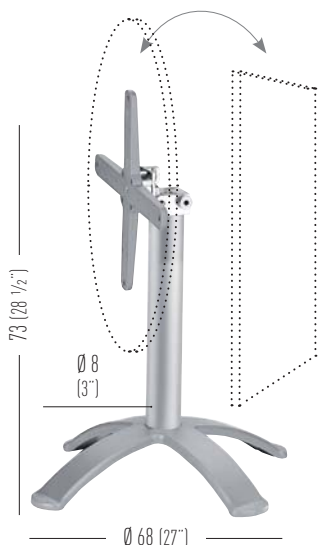

BGPK  0.07m<sup>3</sup> / 27kg / 2pcs € **322,00**

BGPK.10  0.07m<sup>3</sup> / 27kg / 2pcs € **355,00**



# BGPJ

H73 4-spur metal-technopolymer co-injected table base, 80x80mm anodized aluminum column with flip-top mechanism.

Base per tavolo pieghevole H73 a quattro razze in metallo sovrastampato con tecnopolimero, colonna in alluminio anodizzato 80x80mm.

Top max dimensions / Massima dimensione piano

Available table tops / Piani tavolo disponibili

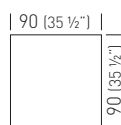
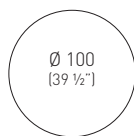

compactop  
laminated  
iron

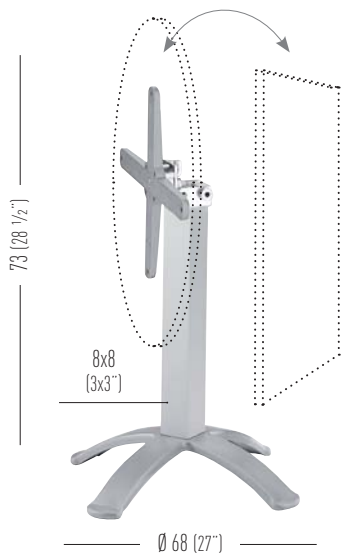

BGPJ  0.10m<sup>3</sup> / 27.60kg / 2pcs € **335,00**

BGPJ.10  0.10m<sup>3</sup> / 27.60kg / 2pcs € **367,00**

# BPG4K

H73 4-spur metal-technopolymer co-injected table base, Ø 60mm anodized aluminum column with cross.

Base per tavolo H73 a quattro razze in metallo sovrastampato con tecnopolimero, colonna in alluminio anodizzato Ø 60mm, crociera.

Top max dimensions / Massima dimensione piano

Available table tops / Piani tavolo disponibili

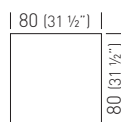
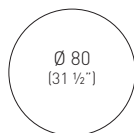

compactop  
laminated  
iron

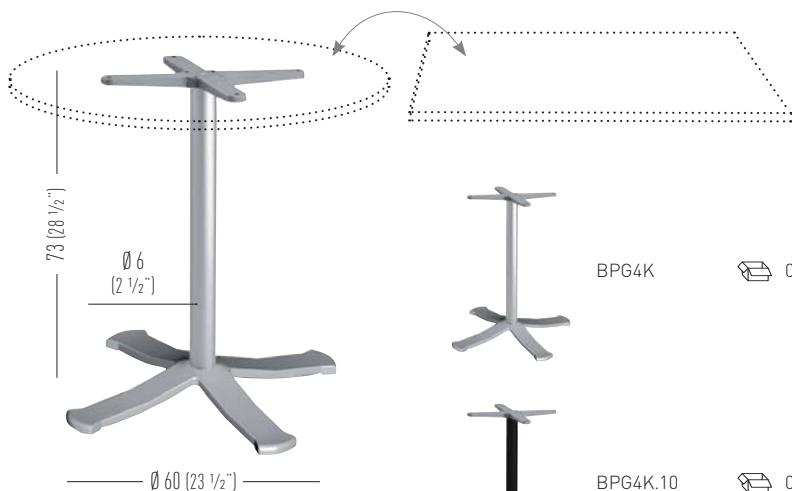

BPG4K  0.07m<sup>3</sup> / 17kg / 2pcs € **202,00**

BPG4K.10  0.07m<sup>3</sup> / 17kg / 2pcs € **220,00**

# BG4IP

H73 stacking 4-spur metal-technopolymer co-injected table base, Ø 80mm round anodized aluminum column with flip-top mechanism. Adjustable feet.

Base per tavolo pieghevole e accatastabile H73 a quattro razze in metallo sovrastampato con tecnopolimero, colonna in alluminio anodizzato Ø 80mm. Piedini regolabili.

Top max dimensions / Massima dimensione piano

Available table tops / Piani tavolo disponibili

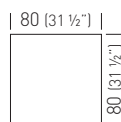
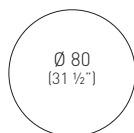

compactop  
laminated  
iron

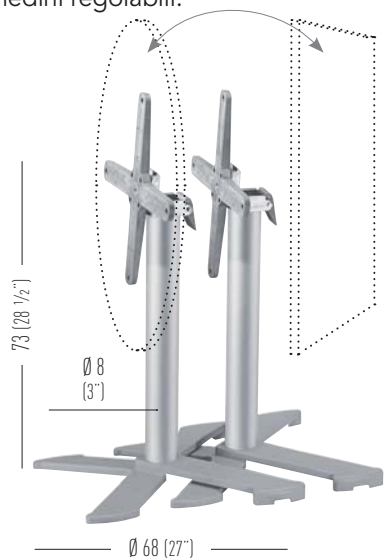

BG4IP

0.07m³ / 20kg / 2pcs

€ 388,00



BG4IP.10

0.07m³ / 20kg / 2pcs

€ 425,00

# BG2J

H73 double metal-technopolymer co-injected table base, 80x80mm anodized aluminum column with cross.

Base doppia per tavolo H73 in metallo sovrastampato con tecnopolimero, colonna in alluminio anodizzato 80x80mm, crociera.

Top max dimensions / Massima dimensione piano

Available table tops / Piani tavolo disponibili

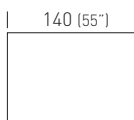

compactop  
laminated  
iron

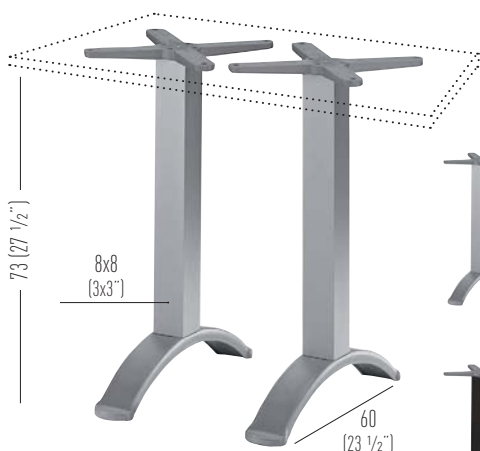

BG2J

0.07m³ / 30kg / 2pcs

€ 343,00



BG2J.10

0.07m³ / 30kg / 2pcs

€ 375,00

# BTK

H73 round metal-technopolymer co-injected table base, Ø 80mm anodized aluminum column with cross.  
Base per tavolo H73 rotonda in metallo sovrastampato con tecnopolimero, colonna in alluminio anodizzato Ø 80mm, crociera.

Top max dimensions / Massima dimensione piano

Available table tops / Piani tavolo disponibili

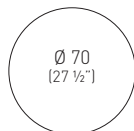

compactop  
laminated  
iron

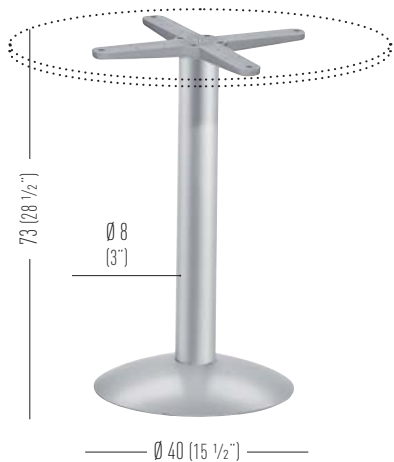

BTK

0.10m<sup>3</sup> / 19.60kg / 2pcs € **160,00**



BTK.10

0.10m<sup>3</sup> / 19.60kg / 2pcs € **172,00**

# BTAk

H110 round metal-technopolymer co-injected table base, Ø 80mm anodized aluminum column with cross.  
Base per tavolo H110 rotonda in metallo sovrastampato con tecnopolimero, colonna in alluminio anodizzato Ø 80mm, crociera.

Top max dimensions / Massima dimensione piano

Available table tops / Piani tavolo disponibili

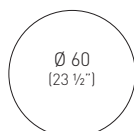

compactop  
laminated  
iron

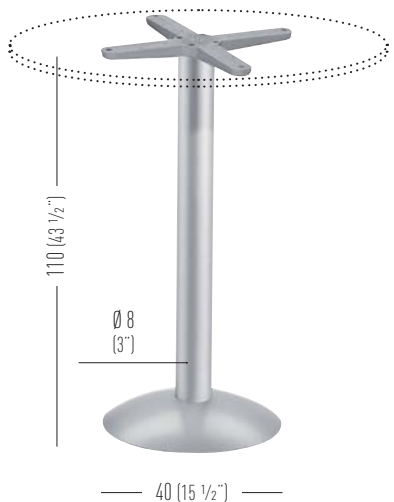

BTAk

0.11m<sup>3</sup> / 21.60kg / 2pcs € **206,00**



BTAk.10

0.11m<sup>3</sup> / 21.60kg / 2pcs € **226,00**

# BTK54

H73 round metal-technopolymer co-injected table base, Ø 80mm anodized aluminum column with cross.

Base per tavolo H73 rotonda in metallo sovrastampato con tecnopolimero, colonna in alluminio anodizzato Ø 80mm, crociera.

Top max dimensions / Massima dimensione piano

Available table tops / Piani tavolo disponibili

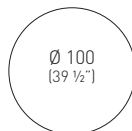

compactop  
laminated  
iron

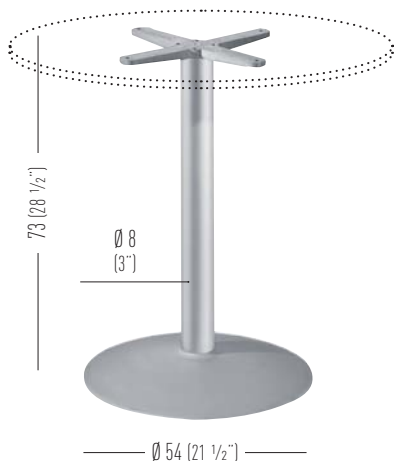

BTK54 0.10m³ / 24.60kg / 2pcs € **184,00**



BTK54.10 0.10m³ / 24.60kg / 2pcs € **203,00**

# BTAK54

H110 round metal-technopolymer co-injected table base, Ø 80mm anodized aluminum column with cross.

Base per tavolo H110 rotonda in metallo sovrastampato con tecnopolimero, colonna in alluminio anodizzato Ø 80mm, crociera.

Top max dimensions / Massima dimensione piano

Available table tops / Piani tavolo disponibili

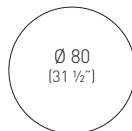

compactop  
laminated  
iron

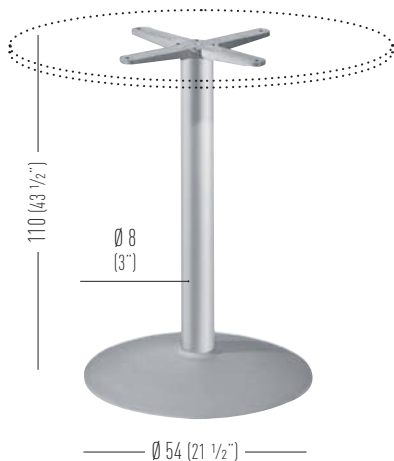

BTAK54 0.11m³ / 25.60kg / 2pcs € **236,00**



BTAK54.10 0.11m³ / 25.60kg / 2pcs € **260,00**

# BRCV

H73 round metal-techno-polymer co-injected table base, Ø 50mm metal painted column with cross.

Base per tavolo H73 rotonda in metallo sovrastampato con tecnopolimero, colonna in metallo verniciato Ø 50mm, crociera.

Top max dimensions / Massima dimensione piano

Available table tops / Piani tavolo disponibili

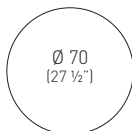

compactop  
laminated  
iron

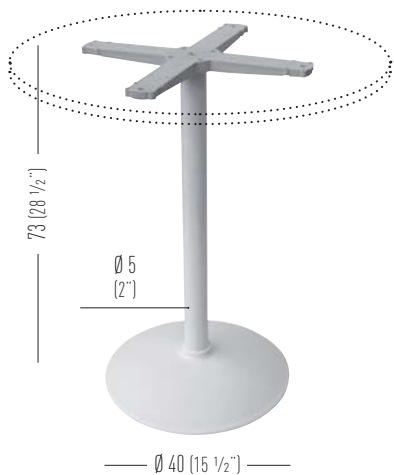

BRCV.00  0.07m³ / 15kg / 2pcs € **181,00**



BRCV.10  0.07m³ / 15kg / 2pcs € **181,00**

# VENUS ROUND

H73 metal-technopolymer co-injected table base, white color.

Base per tavolo H73 rotonda in metallo sovrastampato con tecnopolimero, colore bianco.

Top max dimensions / Massima dimensione piano

Available table tops / Piani tavolo disponibili

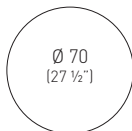



compactop  
laminated  
iron

Additional weight on request (+3).

Peso supplementare disponibile su richiesta (+3).



BGVR.00  0.2m³ / 6kg / 1pcs € **231,00**  
BGVR.00+3kg  0.2m³ / 9kg / 1pcs € **279,00**

# VENUS SQUARE

H73 metal-technopolymer co-injected table base, white color.

Base per tavolo H73 quadrata in metallo sovrastampato con tecnopolimero, colore bianco.

Top max dimensions / Massima dimensione piano

Available table tops / Piani tavolo disponibili

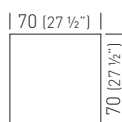

compactop  
laminated  
iron

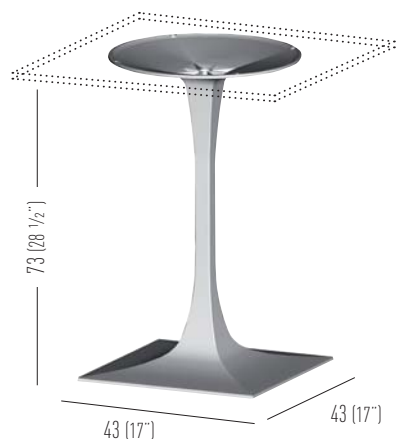

BGVQ.00

0.2m<sup>3</sup> / 7kg / 1pcs

€ 245,00

# BRK

H73 round metal-technopolymer co-injected table base, Ø 80mm anodized aluminum column with cross.

Base per tavolo H73 rotonda in metallo sovrastampato con tecnopolimero, colonna in alluminio anodizzato Ø 80mm, crociera.

Top max dimensions / Massima dimensione piano

Available table tops / Piani tavolo disponibili

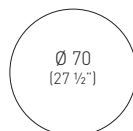

compactop  
laminated  
iron

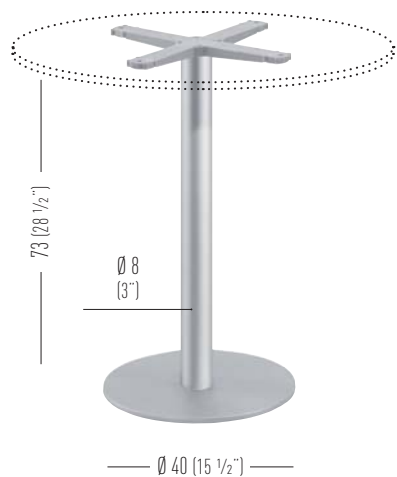

BRK

0.07m<sup>3</sup> / 20.60kg / 2pcs

€ 164,00



BRK.10

0.07m<sup>3</sup> / 20.60kg / 2pcs

€ 180,00

# LEI

H73 or H110 4-spur metal-technopolymer co-injected table base, Ø 60mm anodized aluminum column with cross.

Base per tavolo H73 o H110 a quattro razze in metallo sovrastampato con tecnopolimero, colonna in alluminio anodizzato Ø 60mm, crociera.

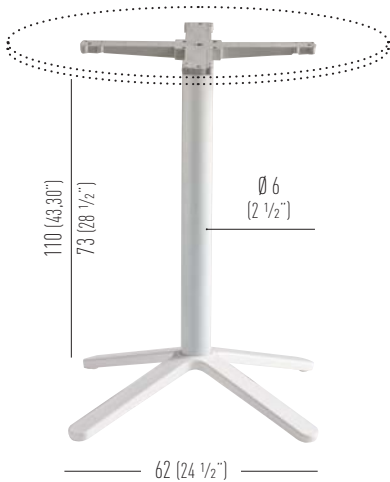

Top max dimensions / Massima dimensione piano

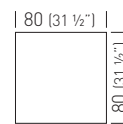

Available table tops / Piani tavolo disponibili

compactop  
laminated  
iron



Only H110 / Solo H110



BLEI.00		0.07m³ / 8.5kg / 1pcs	€ 192,00
BLEIA.00		0.09m³ / 9kg / 1pcs	€ 212,00



BLEI.10		0.07m³ / 8.5kg / 1pcs	€ 192,00
BLEIA.10		0.09m³ / 9kg / 1pcs	€ 212,00

# BQJ

H73 square metal-technopolymer co-injected table base, 80x80mm anodized aluminum column with cross.

Base per tavolo H73 quadrata in metallo sovrastampato con tecnopolimero, colonna in alluminio anodizzato 80x80mm, crociera.

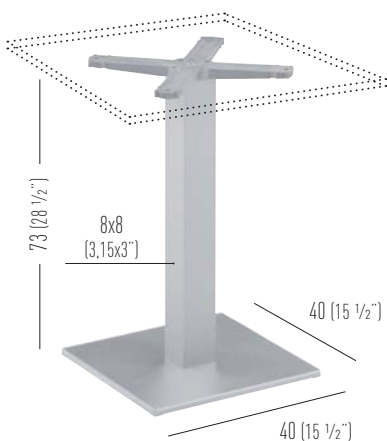

Top max dimensions / Massima dimensione piano

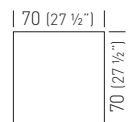

Available table tops / Piani tavolo disponibili

compactop  
laminated  
iron



BQJ		0.07m³ / 24.60kg / 2pcs	€ 181,00
BQJR		0.07m³ / 24.60kg / 2pcs	€ 222,00

Adjustable feet / Piedini regolabili



BQJ.10		0.07m³ / 24.60kg / 2pcs	€ 200,00
BQJR.10		0.07m³ / 24.60kg / 2pcs	€ 240,00

Adjustable feet / Piedini regolabili

# BQAJ

H103 square metal-technopolymer co-injected table base, 80x80mm square anodized aluminum column with cross. Base per tavolo H103 quadrata in metallo sovrastampato con tecnopolimero, colonna quadrata in alluminio anodizzato 80x80mm, crociera.

Top max dimensions / Massima dimensione piano

Available table tops / Piani tavolo disponibili

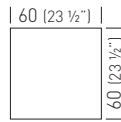

compactop  
laminated  
iron

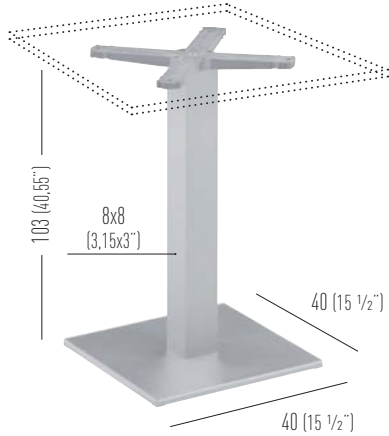

BQAJ  0.08m<sup>3</sup> / 25.60kg / 2pcs € **245,00**

BQAJR  0.08m<sup>3</sup> / 25.60kg / 2pcs € **287,00**

Adjustable feet / Piedini regolabili



BQAJ.10  0.08m<sup>3</sup> / 25.60kg / 2pcs € **268,00**

BQAJR.10  0.08m<sup>3</sup> / 25.60kg / 2pcs € **310,00**

Adjustable feet / Piedini regolabili



# AMICA

H73 4-spur table base collection made of die-cast painted aluminum, Ø60mm polymer-steel co-injected column with cross. Adjustable feet.



Collezione basamenti per tavoli H73 a quattro razze in alluminio pressofuso verniciato, colonna in metallo-polimero Ø60mm, con crociera. Piedini regolabili.

Available table tops / Piani tavolo disponibili

compactop  
laminated  
iron

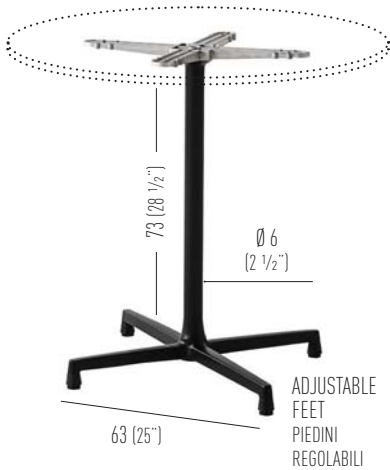

BDA1.00

0.07m<sup>3</sup> / 6.5kg / 1pcs

€ 202,00



BDA1.10

0.07m<sup>3</sup> / 6.5kg / 1pcs

€ 202,00

Top max dimensions / Massima dimensione piano

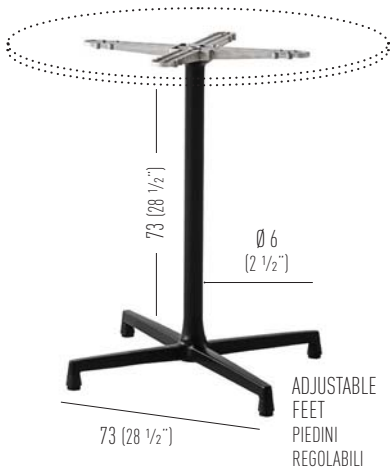
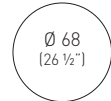
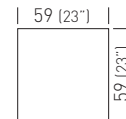

BDA2.00

0.07m<sup>3</sup> / 7kg / 1pcs

€ 211,00



BDA2.10

0.07m<sup>3</sup> / 7kg / 1pcs

€ 211,00

Top max dimensions / Massima dimensione piano

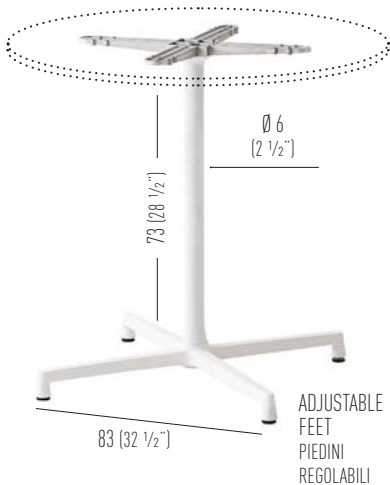
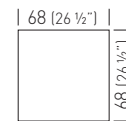

BDA3.00

0.08m<sup>3</sup> / 8kg / 1pcs

€ 223,00



BDA3.10

0.08m<sup>3</sup> / 8kg / 1pcs

€ 223,00

Top max dimensions / Massima dimensione piano

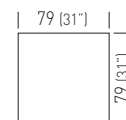

# R1

H50-H74-H110 round steel table base,  
 Ø 80mm steel column with cross.

Base per tavolo rotonda in acciaio  
 H50, H74 e H110, colonna in acciaio Ø  
 80mm, crociera.

Top max dimensions / Massima dimensione piano

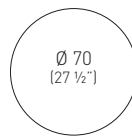

Available table tops / Piani tavolo disponibili

compactop  
 laminated  
 iron

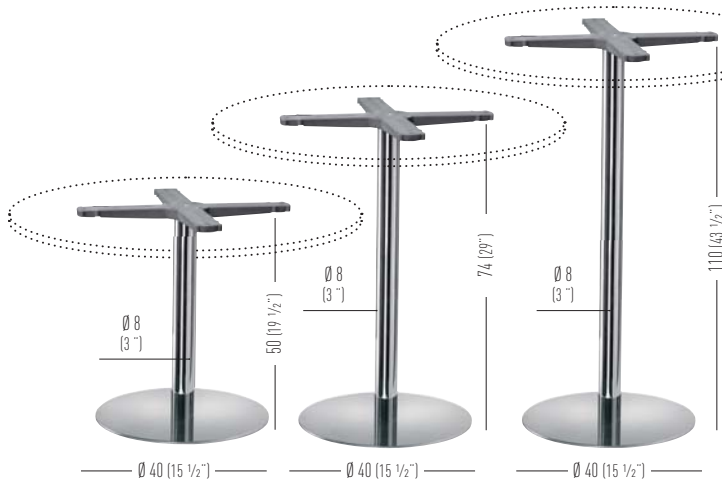

Finishes for R bases / Finiture per basamenti serie R

For orders under 10no. surcharge 20€ each unit

Per ordini inferiori ai 10pz + €20,00 ogni unità.

Polished Steel-Chromed Column / Acciaio Lucido-Colonna Cromata

	H50	BAR1B.A		0.07m³ / 15kg / 1pcs	€ 254,00
	H74	BAR1.A		0.07m³ / 15kg / 1pcs	€ 254,00
	H110	BAR1A.A		0.09m³ / 17kg / 1pcs	€ 296,00

Satin Steel-Satin Column / Acciaio Satinato-Colonna Satinata

	H50	BAR1B.S		0.07m³ / 15kg / 1pcs	€ 265,00
	H74	BAR1.S		0.07m³ / 15kg / 1pcs	€ 265,00
	H110	BAR1A.S		0.09m³ / 17kg / 1pcs	€ 307,00

White Painted / Verniciata Bianca

	H50	BAR1B.00		0.07m³ / 15kg / 1pcs	€ 211,00
	H74	BAR1.00		0.07m³ / 15kg / 1pcs	€ 211,00
	H110	BAR1A.00		0.09m³ / 17kg / 1pcs	€ 256,00

Black Painted / Verniciata Nera

	H50	BAR1B.10		0.07m³ / 15kg / 1pcs	€ 211,00
	H74	BAR1.10		0.07m³ / 15kg / 1pcs	€ 211,00
	H110	BAR1A.10		0.09m³ / 17kg / 1pcs	€ 256,00

# R2

H50-H74-H110 round steel table base,  
 Ø 80mm steel column with cross.

Base per tavolo rotonda in acciaio  
 H50, H74 e H110, colonna in acciaio Ø  
 80mm, crociera.

Top max dimensions / Massima dimensione piano

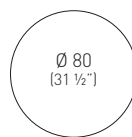

Available table tops / Piani tavolo disponibili

compactop  
 laminated  
 iron

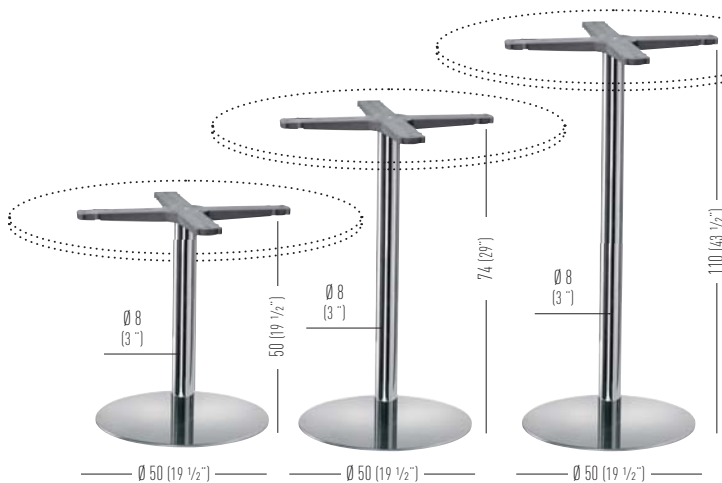

Finishes for R bases / Finiture per basamenti serie R

For orders under 10no. surcharge 20€ each unit

Per ordini inferiori ai 10pz + €20,00 ogni unità.

Polished Steel-Chromed Column / Acciaio Lucido-Colonna Cromata

	H50	BAR2B.A		0.07m³ / 18kg / 1pcs	€ 284,00
	H74	BAR2.A		0.07m³ / 18kg / 1pcs	€ 284,00
	H110	BAR2A.A		0.09m³ / 20kg / 1pcs	€ 326,00

Satin Steel-Satin Column / Acciaio Satinato-Colonna Satinata

	H50	BAR2B.S		0.07m³ / 18kg / 1pcs	€ 336,00
	H74	BAR2.S		0.07m³ / 18kg / 1pcs	€ 336,00
	H110	BAR2A.S		0.09m³ / 20kg / 1pcs	€ 378,00

White Painted / Verniciata Bianca

	H50	BAR2B.00		0.07m³ / 18kg / 1pcs	€ 267,00
	H74	BAR2.00		0.07m³ / 18kg / 1pcs	€ 267,00
	H110	BAR2A.00		0.09m³ / 20kg / 1pcs	€ 310,00

Black Painted / Verniciata Nera

	H50	BAR2B.10		0.07m³ / 18kg / 1pcs	€ 267,00
	H74	BAR2.10		0.07m³ / 18kg / 1pcs	€ 267,00
	H110	BAR2A.10		0.09m³ / 20kg / 1pcs	€ 310,00

# R3

H74-H110 round steel table base,  
 Ø 80mm round steel column with cross.  
 Base per tavolo rotonda in acciaio H74 e  
 H110, colonna rotonda in acciaio  
 Ø 80mm, crociera.

Top max dimensions / Massima dimensione piano

Available table tops / Piani tavolo disponibili

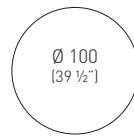

compactop  
 laminated  
 iron

Finishes for R bases / Finiture per basamenti serie R  
 For orders under 10no. surcharge 20€ each unit  
 Per ordini inferiori ai 10pz + €20,00 ogni unità.

Polished Steel-Chromed Column / Acciaio Lucido-Colonna Cromata

	H74	BAR3.A	0.07m³ / 21kg / 1pcs	€ 405,00
	H110	BAR3.A.A	0.09m³ / 23kg / 1pcs	€ 446,00

Satin Steel-Satin Column / Acciaio Satinato-Colonna Satinata

	H74	BAR3.S	0.07m³ / 21kg / 1pcs	€ 405,00
	H110	BAR3.A.S	0.09m³ / 23kg / 1pcs	€ 446,00

White Painted / Verniciata Bianca

	H74	BAR3.00	0.07m³ / 21kg / 1pcs	€ 304,00
	H110	BAR3A.00	0.09m³ / 23kg / 1pcs	€ 347,00

Black Painted / Verniciata Nera

	H74	BAR3.10	0.07m³ / 21kg / 1pcs	€ 304,00
	H110	BAR3A.10	0.09m³ / 23kg / 1pcs	€ 347,00



# V1

H73 roundchromed metal table base,  
 Ø 50mm chromed metal column with  
 cross.  
 Base per tavolo H73 rotonda in metallo  
 cromato, colonna in metallo cromato  
 Ø 50mm, crociera.

Top max dimensions / Massima dimensione piano

Available table tops / Piani tavolo disponibili

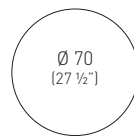

compactop  
 laminated  
 iron

Finishes for V1 bases / Finiture per basamenti serie V1

Polished Steel-Chromed Column / Acciaio Lucido-Colonna Cromata

	H73	BV1C	0.1m³ / 15.6kg / 2 pcs	€ 206,00
--	-----	------	------------------------	----------

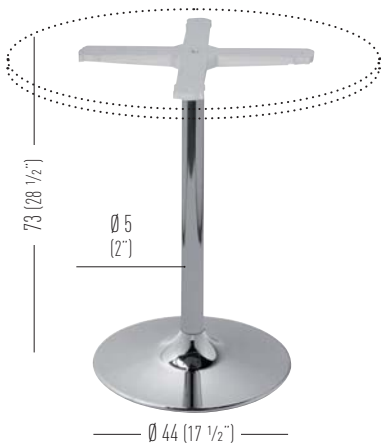

# T1 FLOOR FIXING

Floor Fixing H74 round steel table base, Ø 80mm round steel column with cross.  
Base per tavolo H74 rotonda in metallo per fissaggio a terra, colonna rotonda in metallo Ø 80mm, crociera.

Top max dimensions / Massima dimensione piano

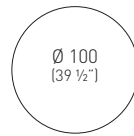

Available table tops / Piani tavolo disponibili

compactop  
laminated  
iron

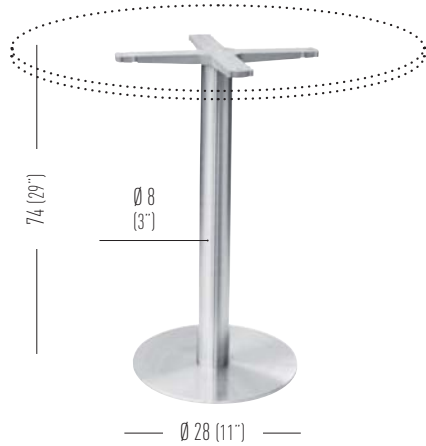

Finishes for T1 bases / Finiture per basamenti serie T1

For orders under 10no. surcharge 20€ each unit

Per ordini inferiori ai 10pz + €20,00 ogni unità.

Polished Steel-Chromed Column / Acciaio Lucido-Colonna Cromata

	H74	BAT1.S	 0.07m³ / 11kg / 1pcs	€ <b>198,00</b>
---	-----	--------	--	-----------------

Min. order 5pcs  
each code  
Ordine min 5pz  
per codice

# Q1

H50-H74-H110 square steel table base, 80x80mm steel column with cross.  
Base per tavolo quadrata in acciaio H50, H74 e H110, colonna in acciaio 80x80mm, crociera.

Top max dimensions / Massima dimensione piano

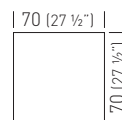

Available table tops / Piani tavolo disponibili

compactop  
laminated  
iron

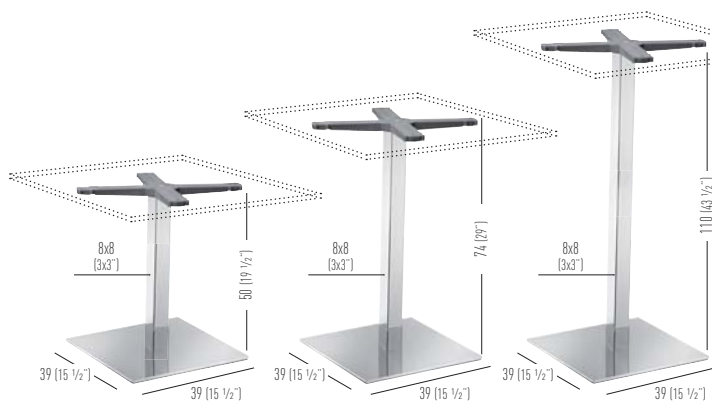

Finishes for Q bases / Finiture per basamenti serie Q

For orders under 10no. surcharge 20€ each unit

Per ordini inferiori ai 10pz + €20,00 ogni unità.

Polished Steel-Chromed Column / Acciaio Lucido-Colonna Cromata

	H50	BAQ1B.A	 0.07m³ / 17kg / 1pcs	€ <b>265,00</b>
	H74	BAQ1.A	 0.07m³ / 17kg / 1pcs	€ <b>265,00</b>
	H110	BAQ1A.A	 0.09m³ / 19kg / 1pcs	€ <b>307,00</b>

Satin Steel-Satin Column / Acciaio Satinato-Colonna Satinata

	H50	BAQ1B.S	 0.07m³ / 17kg / 1pcs	€ <b>288,00</b>
	H74	BAQ1.S	 0.07m³ / 17kg / 1pcs	€ <b>288,00</b>
	H110	BAQ1A.S	 0.09m³ / 19kg / 1pcs	€ <b>333,00</b>

White Painted / Verniciata Bianca

	H50	BAQ1B.00	 0.07m³ / 17kg / 1pcs	€ <b>219,00</b>
	H74	BAQ1.00	 0.07m³ / 17kg / 1pcs	€ <b>219,00</b>
	H110	BAQ1A.00	 0.09m³ / 19kg / 1pcs	€ <b>260,00</b>

Black Painted / Verniciata Nera

	H50	BAQ1B.10	 0.07m³ / 17kg / 1pcs	€ <b>219,00</b>
	H74	BAQ1.10	 0.07m³ / 17kg / 1pcs	€ <b>219,00</b>
	H110	BAQ1A.10	 0.09m³ / 19kg / 1pcs	€ <b>260,00</b>

# Q2

## H50-H74-H110 square steel table base, 80x80mm steel column with cross.

Base per tavolo quadrata in acciaio H50, H74 e H110, colonna in acciaio 80x80mm, crociera.

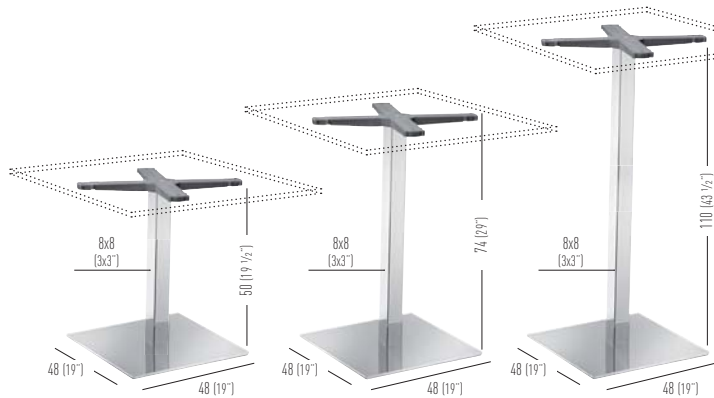

Top max dimensions / Massima dimensione piano

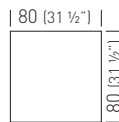

Available table tops / Piani tavolo disponibili

compactop  
laminated  
iron

Finishes for Q bases / Finiture per basamenti serie Q

For orders under 10no. surcharge 20€ each unit  
Per ordini inferiori ai 10pz + €20,00 ogni unità.

Polished Steel-Chromed Column / Acciaio Lucido-Colonna Cromata

	H50	BAQ2B.A		0.07m <sup>3</sup> / 18kg / 1pcs	€ 344,00
	H74	BAQ2.A		0.07m <sup>3</sup> / 18kg / 1pcs	€ 344,00
	H110	BAQ2A.A		0.09m <sup>3</sup> / 20kg / 1pcs	€ 389,00

Satin Steel-Satin Column / Acciaio Satinato-Colonna Satinata

	H50	BAQ2B.S		0.07m <sup>3</sup> / 18kg / 1pcs	€ 352,00
	H74	BAQ2.S		0.07m <sup>3</sup> / 18kg / 1pcs	€ 352,00
	H110	BAQ2A.S		0.09m <sup>3</sup> / 20kg / 1pcs	€ 394,00

White Painted / Verniciata Bianca

	H50	BAQ2B.00		0.07m <sup>3</sup> / 18kg / 1pcs	€ 276,00
	H74	BAQ2.00		0.07m <sup>3</sup> / 18kg / 1pcs	€ 276,00
	H110	BAQ2A.00		0.09m <sup>3</sup> / 20kg / 1pcs	€ 321,00

Black Painted / Verniciata Nera

	H50	BAQ2B.10		0.07m <sup>3</sup> / 18kg / 1pcs	€ 276,00
	H74	BAQ2.10		0.07m <sup>3</sup> / 18kg / 1pcs	€ 276,00
	H110	BAQ2A.10		0.09m <sup>3</sup> / 20kg / 1pcs	€ 321,00

# Q3

## H74-H110 square steel table base, 80x80mm steel column with cross.

Base per tavolo quadrata in acciaio H74 e H110, colonna in acciaio 80x80mm, crociera.

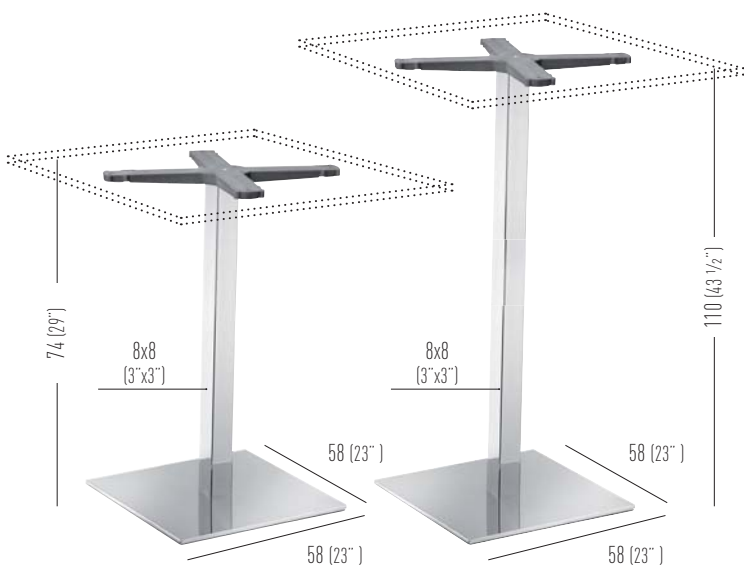

Top max dimensions / Massima dimensione piano

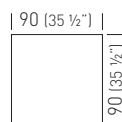

Available table tops / Piani tavolo disponibili

compactop  
laminated  
iron

Finishes for Q bases / Finiture per basamenti serie Q

For orders under 10no. surcharge 20€ each unit  
Per ordini inferiori ai 10pz + €20,00 ogni unità.

Polished Steel-Chromed Column / Acciaio Lucido-Colonna Cromata

	H74	BAQ3.A		0.07m <sup>3</sup> / 23kg / 1pcs	€ 425,00
	H110	BAQ3A.A		0.09m <sup>3</sup> / 25kg / 1pcs	€ 467,00

Satin Steel-Satin Column / Acciaio Satinato-Colonna Satinata

	H74	BAQ3.S		0.07m <sup>3</sup> / 23kg / 1pcs	€ 428,00
	H110	BAQ3A.S		0.09m <sup>3</sup> / 25kg / 1pcs	€ 471,00

White Painted / Verniciata Bianca

	H74	BAQ3.00		0.07m <sup>3</sup> / 23kg / 1pcs	€ 318,00
	H110	BAQ3A.00		0.09m <sup>3</sup> / 25kg / 1pcs	€ 361,00

Black Painted / Verniciata Nera

	H74	BAQ3.10		0.07m <sup>3</sup> / 23kg / 1pcs	€ 318,00
	H110	BAQ3A.10		0.09m <sup>3</sup> / 25kg / 1pcs	€ 361,00

# D2

H74-H110 double steel table base,  
80x80mm steel columns with cross.  
Base doppia per tavolo H74 e H110 in  
acciaio, colonne in acciaio 80x80mm,  
crociere.

Top max dimensions / Massima dimensione piano

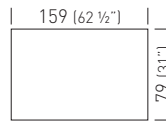

Available table tops / Piani tavolo disponibili

compactop  
laminated  
iron

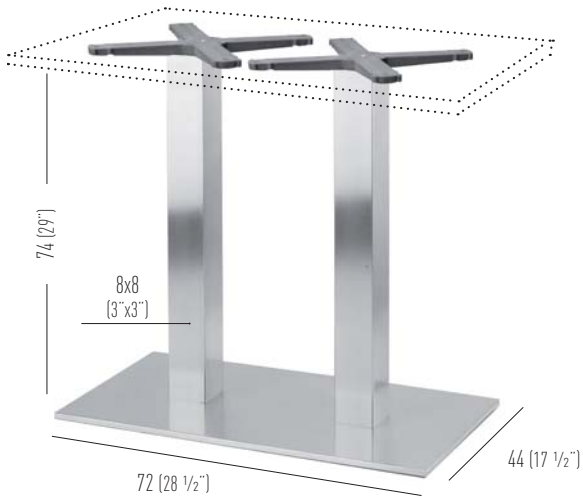

Finishes for D2 bases / Finiture per basamenti serie D2

Polished Steel-Chromed Column / Acciaio Lucido-Colonna Cromata



H74 BAD2.A  0.22m<sup>3</sup> / 32kg / 1pcs € **432,00**

Satin Steel-Satin Column / Acciaio Satinato-Colonna Satinata



H74 BAD2.S  0.22m<sup>3</sup> / 32kg / 1pcs € **473,00**

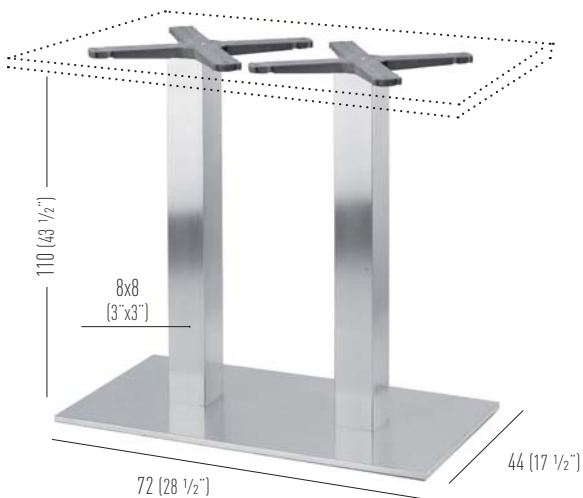

Polished Steel-Chromed Column / Acciaio Lucido-Colonna Cromata



H110 BAD2.A.A  0.22m<sup>3</sup> / 35kg / 1pcs € **493,00**

Satin Steel-Satin Column / Acciaio Satinato-Colonna Satinata



H110 BAD2.A.S  0.22m<sup>3</sup> / 35kg / 1pcs € **532,00**

# ALFIE

H72 4-Spur table base collection made of painted steel, Ø100mm metal painted column with cross. Adjustable feet. Collezione basamenti per tavoli, H72, quattro razze in acciaio verniciato, colonna in metallo verniciato Ø100mm con crociera. Piedini regolabili.



Available top sizes / Dimensioni piano disponibili

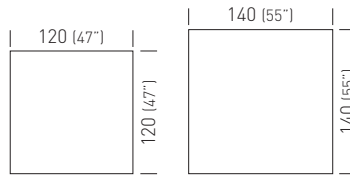
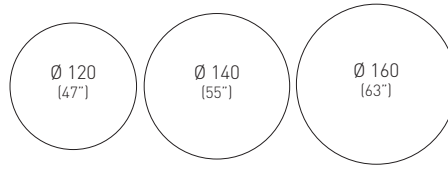

Available table tops / Piani tavolo disponibili

laminated

Black Painted / Verniciata Nera



BALF.10

0.13m<sup>3</sup> / 15kg / 1pcs

€ **538,00**

# TATAMI

## H74-H110 round steel table base, Ø 80mm steel similar wood-effect column with cross.

Base per tavolo rotonda in acciaio H74  
e H110, colonna finto legno Ø 80mm,  
crociera.

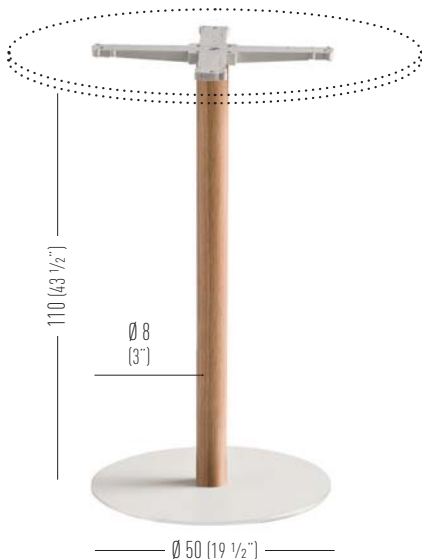
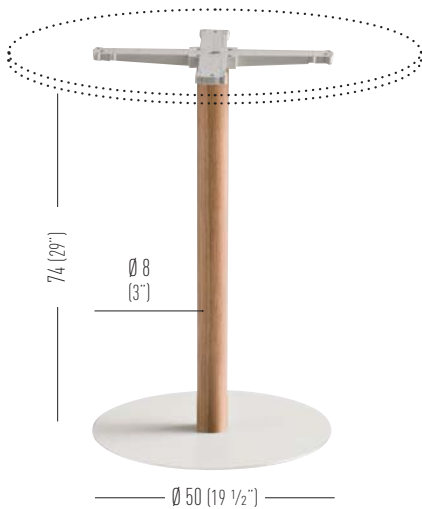

Top max dimensions / Massima dimensione piano

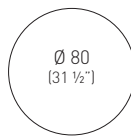

Available table tops / Piani tavolo disponibili

compactop  
laminated  
iron

Finishes for TATAMI bases / Finiture per basamenti serie Tatami

For orders under 10no. surcharge 20€ each unit

Per ordini inferiori ai 10pz + €20,00 ogni unità.

Polished Steel / Acciaio Lucido



BART.A-<sub>-</sub>



0.07m<sup>3</sup> / 18kg / 1pcs

€ 329,00

Satin Steel / Acciaio Satinato



BART.S-<sub>-</sub>



0.07m<sup>3</sup> / 18kg / 1pcs

€ 353,00

White Painted / Verniciata Bianca



BART.00-<sub>-</sub>



0.07m<sup>3</sup> / 18kg / 1pcs

€ 282,00

Black Painted / Verniciata Nera



BART.10-<sub>-</sub>



0.07m<sup>3</sup> / 18kg / 1pcs

€ 282,00

Finishes for Tatami columns / Finiture per colonne serie Tatami



F

Natural Beech effect  
Faggio Naturale finto legno



RN

Oak effect  
Rovere finto legno

Finishes for TATAMI bases / Finiture per basamenti serie Tatami

For orders under 10no. surcharge 20€ each unit

Per ordini inferiori ai 10pz + €20,00 ogni unità.

Polished Steel / Acciaio Lucido



BART.A.A-<sub>-</sub>



0.09m<sup>3</sup> / 20kg / 1pcs

€ 375,00

Satin Steel / Acciaio Satinato



BART.A.S-<sub>-</sub>



0.09m<sup>3</sup> / 20kg / 1pcs

€ 401,00

White Painted / Verniciata Bianca



BART.A.00-<sub>-</sub>



0.09m<sup>3</sup> / 20kg / 1pcs

€ 329,00

Black Painted / Verniciata Nera



BART.A.10-<sub>-</sub>



0.09m<sup>3</sup> / 20kg / 1pcs

€ 329,00

Finishes for Tatami columns / Finiture per colonne serie Tatami



F

Natural Beech effect  
Faggio Naturale finto legno



RN

Oak effect  
Rovere finto legno



# LOL3 BASE

H49-H74 3-spur table base collection,  
made of steel treated for outdoor use,  
matt finish.

Basamento per tavolo H49-H74 a tre razze,  
realizzato in acciaio trattato per esterni,  
finitura opaca.



Only for the base  
Solo per il basamento

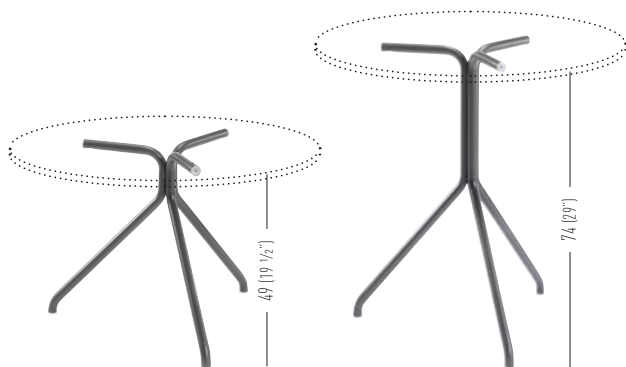

Top max dimensions / Massima dimensione piano

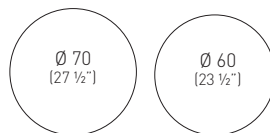

Available table tops / Piani tavolo disponibili

laminated

Frame Color / Colore Struttura

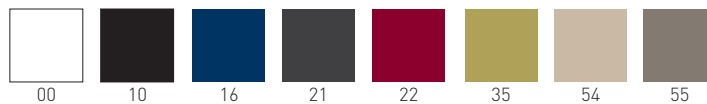

H49	BLOL3._/H49	0.17m³ / 3.5kg / 1pc	€	<b>133,00</b>
H74	BLOL3._/H74	0.24m³ / 4.1kg / 1pc	€	<b>138,00</b>

Min. order 10pcs  
each code  
Ordine min 10pz  
per codice

Top max dimensions / Massima dimensione piano

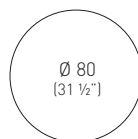

Available table tops / Piani tavolo disponibili

laminated



Only for the base  
Solo per il basamento

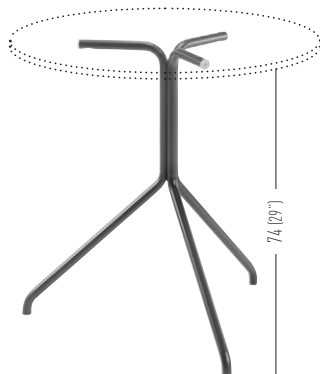

Frame Color / Colore Struttura

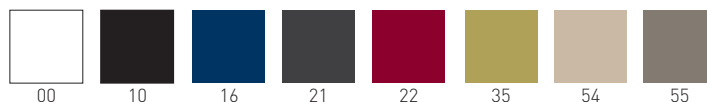

H74L	BLOL3L._/H74	0.43m³ / 4.2Kg / 1pc	€	<b>147,00</b>
------	--------------	----------------------	---	---------------

Min. order 10pcs  
each code  
Ordine min 10pz  
per codice

# LOL4 BASE

H74 4-spur table base collection, made of steel treated for outdoor use, matt finish. Basamento per tavolo H74 a quattro razze, realizzato in acciaio trattato per esterni, finitura opaca.



Only for the base  
Solo per il basamento

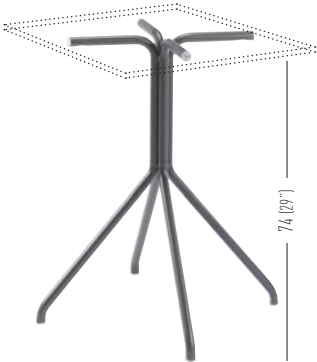

Top max dimensions / Massima dimensione piano

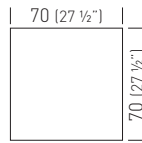

Available table tops / Piani tavolo disponibili

compactop  
laminated

Frame Color / Colore Struttura

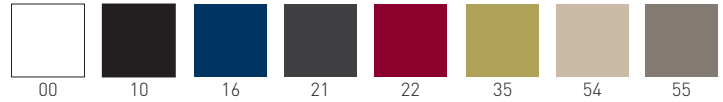

H74 BLOL4.\_/H74 0.24m<sup>3</sup> / 4.9kg / 1pc € **149,00**

Min. order 10pcs  
each code  
Ordine min 10pz  
per codice

Top max dimensions / Massima dimensione piano

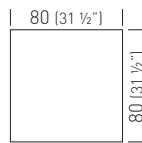

Available table tops / Piani tavolo disponibili

compactop  
laminated

Frame Color / Colore Struttura

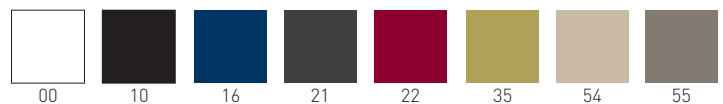

H74L BLOL4L.\_/H74 0.35m<sup>3</sup> / 5.2kg / 1pc € **157,00**

Min. order 10pcs  
each code  
Ordine min 10pz  
per codice



Only for the base  
Solo per il basamento

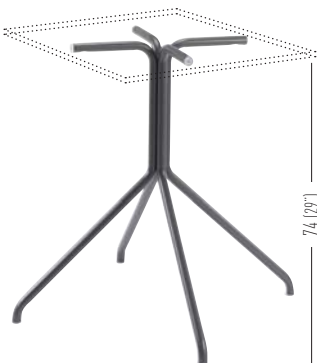

# LOL PLUS BASE

The Lol Plus table bases collection is made of steel, the cross is made in die cast aluminum, and provided with flip-top joint. The shape of the base and the flip-top mechanism allow the table to easily fold and stack, space-saving. The available colour palette is common to many Gaber seating collections, guaranteeing tone-on-tone colour co-ordination throughout designed settings rather than lively contrasts, defining various colour combinations between bases, tops and seating.

La Collezione di basamenti Lol Plus è realizzata in acciaio, la crociera è realizzata in presso fusione di alluminio, ed è dotata di giunto per la rotazione del piano. La forma della base e la meccanica che permette la rotazione del piano in posizione verticale, rendono il tavolo facilmente accatastabile in spazi ridotti. La palette di colori disponibile è comune a molte collezioni di sedute Gaber, garantendo abbinamenti tono su tono degli ambienti progettati, piuttosto che vivaci contrasti, definendo diverse combinazioni di colori tra basi, piani e sedute.

Top max dimensions / Massima dimensione piano

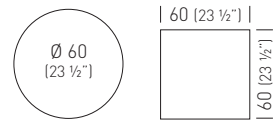

Available table tops / Piani tavolo disponibili

compactop  
laminated

Frame Color / Colore Struttura

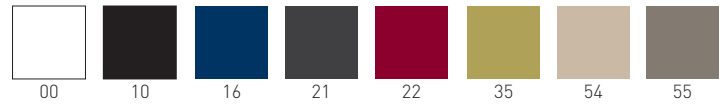

H74

BLOLP\_/\_/H74



0.24m3 / 5.3kg / 1pc

€ **262,00**

Min. order 10pcs  
each code  
Ordine min 10pz  
per codice



Only for the base  
Solo per il basamento

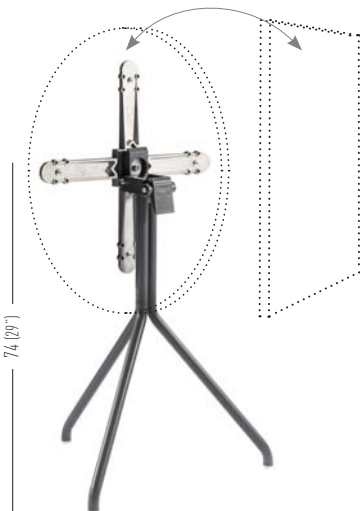

# BRISTOL BASE

4-spur H74 table base in epoxy powder coated steel treated for outdoor use, and equipped with adjustable feet.

Basamento per tavolo H74 con struttura a quattro razze, dotato di piedini regolabili, in acciaio verniciato a polveri epossidiche con trattamento per esterno.

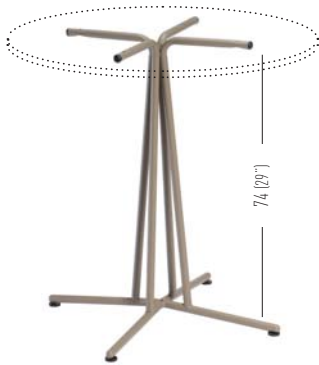

Top max dimensions / Massima dimensione piano

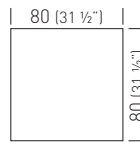

Available table tops / Piani tavolo disponibili

compactop  
laminated

Frame Color / Colore Struttura

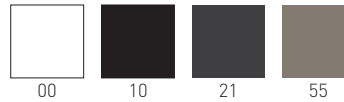

H74 BBR5\_/\_/H74  0.23m3 / 5.5kg / 1pc € **197,00**

Minimum order 20 pcs each code, unless combined with Gaber table tops.  
Ordine minimo 20 pezzi per codice, se non abbinato a piani Gaber.

# GLITTER BASE

H74 and H105 tripod table bases in epoxy powder coated steel with outdoor treatment.

Basamento per tavolo H74-H105 con struttura a tre punti di appoggio, realizzato in acciaio verniciato a polveri epossidiche con trattamento per esterno.



Top max dimensions / Massima dimensione piano

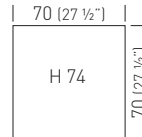
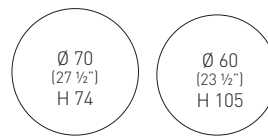

Available table tops / Piani tavolo disponibili

compactop  
laminated



Frame Color / Colore Struttura

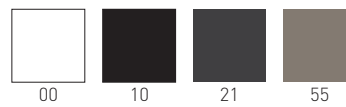

H74	BGLT.__/H74	0.18m3 / 2.9kg / 1pc	€ <b>169,00</b>
H105	BGLT.__/H105	0.18m3 / 3.55kg / 1pc	€ <b>211,00</b>

Minimum order 20 pcs each code, unless combined with Gaber table tops.  
Ordine minimo 20 pezzi per codice, se non abbinato a piani Gaber.

OFFICE &  
WORKSPACES  
**System**

# Workstation 2027



This office furniture collection is intended for modern workplaces. It is distinguished by simple and rational worktop lines as well as slender and resistant support frames with a trestle shape. The service cabinets are suspended, a feature designed for easy and modern cleaning. The desks can be equipped with high-performance sound-absorbing screens, to improve privacy and the general acoustics of the workplace. The assembly systems have been especially designed to be fast and safe.

Programma d'arredo destinato ad uffici moderni con piani di lavoro dalle linee semplici e razionali, strutture di sostegno con forma a cavalletto per essere snelle e resistenti. I mobili di servizio sono sospesi, caratteristica pensata per una semplice e moderna pulizia automatica. Le scrivanie possono essere dotate di schermi divisorii per migliorare la privacy e l'acustica. I sistemi di assemblaggio sono veloci e sicuri.

## Finishings / Finiture

Melamine Laquered Cabinets Colors  
(Antibacterial water-base laquering)  
Colori Laccati Mobili Melaminico  
(Laccatura antibatterica a base acqua)



Frame colors  
Colori struttura



Melamine Cabinets Color  
Colore Mobili Melaminico



Laminated top color  
ABS Edge  
Colori piano laminato  
Bordo ABS



White Matte Laquered Neve (00) / Black Matte Laquered (10) / Blue Matte Laquered 5003 (16) / Grey Matte Laquered Antracite (21) / Bordeaux Matte Laquered 3004 (22)  
Lime Matte Laquered Limone (35) / Mineral Grey Matte Laquered 7006 (55)



**Option:** Cod. 1101

Cable Routing Option, anodized Aluminum 8x8 cm, black brush  
Opzione Passacavi, Alluminio anodizzato 8x8 cm spazzolina nera

€



**Option:** Cod. ACCV030\_

Metal Fairlead Solution  
Tubo metallico passacavi

€

## WORKSTATION 2027 DX VERSION 180



Workstation with 2027 structure, cabinet consisting of module with sliding doors and lock, 1 partition and 1 shelf per compartment, open module with 1 shelf. Straight desktop white colour, thickness 22mm.

Stazione di lavoro con struttura 2027, mobile composto da modulo con ante scorrevoli e serratura, 1 tramezza e 1 ripiano per vano, modulo a giorno con 1 ripiano. Piano scrivania di lavoro diritta di colore bianco, spessore 22mm.

Melamine Laquered Cabinets Colors  
Colori Laccati Mobili Melaminico



Frame colors  
Colori struttura



Melamine Cabinets Color  
Colore Mobili Melaminico



Laminated top color  
Colori piano laminato

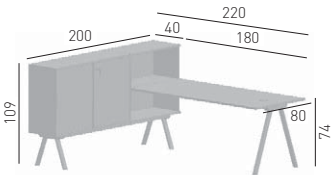

Unassembled structure, individual modules assembled.  
Struttura non assemblata, singoli moduli assemblati.



1,07 m<sup>3</sup>  
114,5 kg.

Finishing & Codes / Finiture e Codici

Melamine Cabinets / Mobili in Melaminico

cod. **WRKMD1D.00-00/PK\_\_**

Melamine Laquered Cabinets / Mobili in Melaminico Laccato

cod. **WRKQD1D.\_\_-00/PK\_\_**

€ **124,00**

€ **3226,00**

## WORKSTATION 2027 SX VERSION 180



Workstation with 2027 structure, cabinet consisting of module with sliding doors and lock, 1 partition and 1 shelf per compartment, open module with 1 shelf. Straight desktop white colour, thickness 22mm.

Stazione di lavoro con struttura 2027, mobile composto da modulo con ante scorrevoli e serratura, 1 tramezza e 1 ripiano per vano, modulo a giorno con 1 ripiano. Piano scrivania di lavoro diritta di colore bianco, spessore 22mm.

Melamine Laquered Cabinets Colors  
Colori Laccati Mobili Melaminico



Frame colors  
Colori struttura



Melamine Cabinets Color  
Colore Mobili Melaminico



Laminated top color  
Colori piano laminato

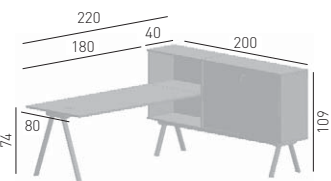

Unassembled structure, individual modules assembled.  
Struttura non assemblata, singoli moduli assemblati.



1,07 m<sup>3</sup>  
114,5 kg.

Finishing & Codes / Finiture e Codici

Melamine Cabinets / Mobili in Melaminico

cod. **WRKMD1S.00-00/PK\_\_**

Melamine Laquered Cabinets / Mobili in Melaminico Laccato

cod. **WRKQD1S.\_\_-00/PK\_\_**

€ **2306,00**

€ **3226,00**



## WORKSTATION 2027 DX VERSION 240



Workstation with 2027 structure, cabinet consisting of module with sliding doors and lock, 1 partition and 1 shelf per compartment, open module with 1 shelf. Straight desktop white colour, thickness 22mm.

Stazione di lavoro con struttura 2027, mobile composto da modulo con ante scorrevoli e serratura, 1 tramezza e 1 ripiano per vano, modulo a giorno con 1 ripiano. Piano scrivania di lavoro diritta di colore bianco, spessore 22mm.

Melamine Laquered Cabinets Colors  
Colori Laccati Mobili Melaminico

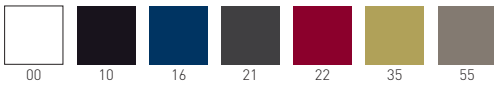

Frame colors  
Colori struttura



Melamine Cabinets Color  
Colore Mobili Melaminico



Laminated top color  
Colori piano laminato

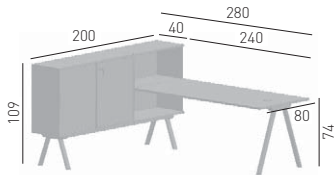

Unassembled structure, individual modules assembled.  
Struttura non assemblata, singoli moduli assemblati.



1,12 m<sup>3</sup>  
124,5 kg.

Finishing & Codes / Finiture e Codici

Melamine Cabinets / Mobili in Melaminico

cod. **WRKMD2D.00-00/PK\_\_**

Melamine Laquered Cabinets / Mobili in Melaminico Laccato

cod. **WRKQD2D.\_\_-00/PK\_\_**

€ **2561,00**

€ **3467,00**

## WORKSTATION 2027 SX VERSION 240



Workstation with 2027 structure, cabinet consisting of module with sliding doors and lock, 1 partition and 1 shelf per compartment, open module with 1 shelf. Straight desktop white colour, thickness 22mm.

Stazione di lavoro con struttura 2027, mobile composto da modulo con ante scorrevoli e serratura, 1 tramezza e 1 ripiano per vano, modulo a giorno con 1 ripiano. Piano scrivania di lavoro diritta di colore bianco, spessore 22mm.

Melamine Laquered Cabinets Colors  
Colori Laccati Mobili Melaminico



Frame colors  
Colori struttura



Melamine Cabinets Color  
Colore Mobili Melaminico



Laminated top color  
Colori piano laminato

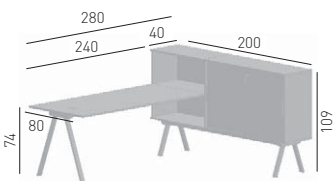

Unassembled structure, individual modules assembled.  
Struttura non assemblata, singoli moduli assemblati.



1,12 m<sup>3</sup>  
124,5 kg.

Finishing & Codes / Finiture e Codici

Melamine Cabinets / Mobili in Melaminico

cod. **WRKMD2S.00-00/PK\_\_**

Melamine Laquered Cabinets / Mobili in Melaminico Laccato

cod. **WRKQD2S.\_\_-00/PK\_\_**

€ **2561,00**

€ **3467,00**

## WORKSTATION 2027 DX L-VERSION 180



Workstation with 2027 structure, cabinet consisting of module with sliding doors and lock, 1 partition and 1 shelf per compartment, open module with 1 shelf. Wraparound work desktop white colour, thickness 22mm.

Stazione di lavoro con struttura 2027, mobile composto da modulo con ante scorrevoli e serratura, 1 tramezza e 1 ripiano per vano, modulo a giorno con 1 ripiano. Piano scrivania di lavoro avvolgente di colore bianco, spessore 22mm.

Melamine Laquered Cabinets Colors  
Colori Laccati Mobili Melaminico

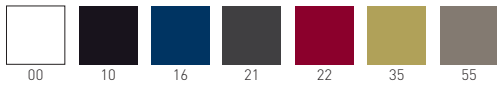

Frame colors  
Colori struttura



Melamine Cabinets Color  
Colore Mobili Melaminico



Laminated top color  
Colori piano laminato

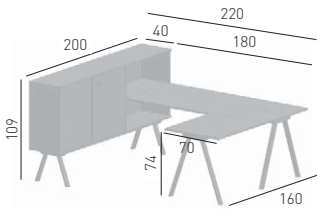

Unassembled structure, individual modules assembled.  
Struttura non assemblata, singoli moduli assemblati.



1,12 m<sup>3</sup>  
129,5 kg.

Finishing & Codes / Finiture e Codici

Melamine Cabinets / Mobili in Melaminico

cod. **WRKML1D.00-00/PK\_\_**

Melamine Laquered Cabinets / Mobili in Melaminico Laccato

cod. **WRKQL1D.\_\_-00/PK\_\_**

€ **2739,00**

€ **3587,00**

## WORKSTATION 2027 SX L-VERSION 180



Workstation with 2027 structure, cabinet consisting of module with sliding doors and lock, 1 partition and 1 shelf per compartment, open module with 1 shelf. Wraparound work desktop white colour, thickness 22mm.

Stazione di lavoro con struttura 2027, mobile composto da modulo con ante scorrevoli e serratura, 1 tramezza e 1 ripiano per vano, modulo a giorno con 1 ripiano. Piano scrivania di lavoro avvolgente di colore bianco, spessore 22mm.

Melamine Laquered Cabinets Colors  
Colori Laccati Mobili Melaminico



Frame colors  
Colori struttura



Melamine Cabinets Color  
Colore Mobili Melaminico



Laminated top color  
Colori piano laminato

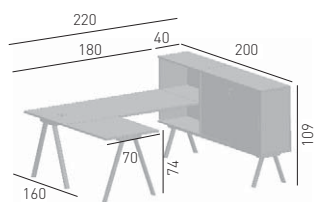

Unassembled structure, individual modules assembled.  
Struttura non assemblata, singoli moduli assemblati.



1,12 m<sup>3</sup>  
129,5 kg.

Finishing & Codes / Finiture e Codici

Melamine Cabinets / Mobili in Melaminico

cod. **WRKML1S.00-00/PK\_\_**

Melamine Laquered Cabinets / Mobili in Melaminico Laccato

cod. **WRKQL1S.\_\_-00/PK\_\_**

€ **2739,00**

€ **3587,00**

## WORKSTATION 2027 DX L-VERSION 240



Workstation with 2027 structure, cabinet consisting of module with sliding doors and lock, 1 partition and 1 shelf per compartment, open module with 1 shelf. Wraparound work desktop white colour, thickness 22mm.

Stazione di lavoro con struttura 2027, mobile composto da modulo con ante scorrevoli e serratura, 1 tramezza e 1 ripiano per vano, modulo a giorno con 1 ripiano. Piano scrivania di lavoro avvolgente di colore bianco, spessore 22mm.

Melamine Laquered Cabinets Colors  
Colori Laccati Mobili Melaminico



Frame colors  
Colori struttura

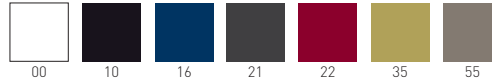

Melamine Cabinets Color  
Colore Mobili Melaminico



Laminated top color  
Colori piano laminato

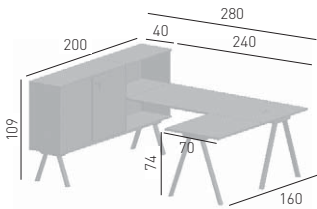

Unassembled structure, individual modules assembled.  
Struttura non assemblata, singoli moduli assemblati.



1,17 m<sup>3</sup>  
139,5 kg.

Finishing & Codes / Finiture e Codici

Melamine Cabinets / Mobili in Melaminico

cod. **WRKML2D.00-00/PK\_\_**

Melamine Laquered Cabinets / Mobili in Melaminico Laccato

cod. **WRKQL2D.\_\_-00/PK\_\_**

€ **2943,00**

€ **4126,00**

## WORKSTATION 2027 SX L-VERSION 240



Workstation with 2027 structure, cabinet consisting of module with sliding doors and lock, 1 partition and 1 shelf per compartment, open module with 1 shelf. Wraparound work desktop white colour, thickness 22mm.

Stazione di lavoro con struttura 2027, mobile composto da modulo con ante scorrevoli e serratura, 1 tramezza e 1 ripiano per vano, modulo a giorno con 1 ripiano. Piano scrivania di lavoro avvolgente di colore bianco, spessore 22mm.

Melamine Laquered Cabinets Colors  
Colori Laccati Mobili Melaminico



Frame colors  
Colori struttura



Melamine Cabinets Color  
Colore Mobili Melaminico



Laminated top color  
Colori piano laminato

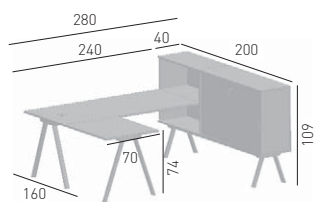

Unassembled structure, individual modules assembled.  
Struttura non assemblata, singoli moduli assemblati.



1,17 m<sup>3</sup>  
139,5 kg.

Finishing & Codes / Finiture e Codici

Melamine Cabinets / Mobili in Melaminico

cod. **WRKML2S.00-00/PK\_\_**

Melamine Laquered Cabinets / Mobili in Melaminico Laccato

cod. **WRKQL2S.\_\_-00/PK\_\_**

€ **2943,00**

€ **4126,00**

## WORKSTATION 2027 DX VERSION 180 WITH BENCH



Workstation with 2027 structure, cabinet consisting of module with sliding doors and lock, 1 partition and 1 shelf per compartment, open module with 1 shelf. Straight desktop white colour, thickness 22mm. Bench module with padded and upholstered seats.

Stazione di lavoro con struttura 2027, mobile composto da modulo con ante scorrevoli e serratura, 1 tramezza e 1 ripiano per vano, modulo a giorno con 1 ripiano. Piano scrivania di lavoro diritta di colore bianco, spessore 22mm. Modulo panca con sedute imbottite e tappezzate.

BENCH module available coverings / Finiture disponibili modulo panca  
 King fabric / Tessuto King **K**  
 Aurea eco-leather / Ecopelle Aurea **E**  
 Blazer fabric / Tessuto Blazer **B**  
 Leather / Pelle **P**  
 Kvadrat fabrics / Tessuti Kvadrat **DK**

Melamine Laquered Cabinets Colors  
 Colori Laccati Mobili Melaminico



Frame colors  
 Colori struttura

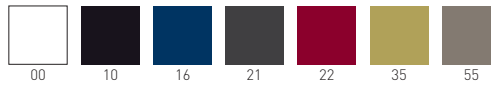

Melamine Cabinets Color  
 Colore Mobili Melaminico



Laminated top color  
 Colori piano laminato

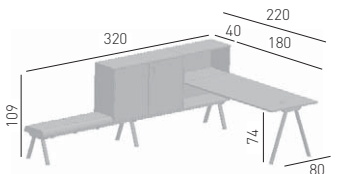

Unassembled structure, individual modules assembled.  
 Struttura non assemblata, singoli moduli assemblati.



1,14 m<sup>3</sup>  
 122,1 kg.

Finishing & Codes / Finiture e Codici

Melamine Cabinets / Mobili in Melaminico

cod. WRKMD1DP.00-00-_(K)/PK__	€	2976,00
cod. WRKMD1DP.00-00-_(E)/PK__	€	2976,00
cod. WRKMD1DP.00-00-_(B)/PK__	€	3069,00
cod. WRKMD1DP.00-00-_(P)/PK__	€	3351,00
cod. WRKMD1DP.00-00-_(DK)/PK__	€	3351,00

Melamine Laquered Cabinets / Mobili in Melaminico Laccato

cod. WRKQD1DP.__-00-_(K)/PK__	€	3860,00
cod. WRKQD1DP.__-00-_(E)/PK__	€	3860,00
cod. WRKQD1DP.__-00-_(B)/PK__	€	3954,00
cod. WRKQD1DP.__-00-_(P)/PK__	€	4047,00
cod. WRKQD1DP.__-00-_(DK)/PK__	€	4047,00

## WORKSTATION 2027 SX VERSION 180 WITH BENCH



Workstation with 2027 structure, cabinet consisting of module with sliding doors and lock, 1 partition and 1 shelf per compartment, open module with 1 shelf. Straight desktop white colour, thickness 22mm. Bench module with padded and upholstered seats.

Stazione di lavoro con struttura 2027, mobile composto da modulo con ante scorrevoli e serratura, 1 tramezza e 1 ripiano per vano, modulo a giorno con 1 ripiano. Piano scrivania di lavoro diritta di colore bianco, spessore 22mm. Modulo panca con sedute imbottite e tappezzate.

BENCH module available coverings / Finiture disponibili modulo panca  
 King fabric / Tessuto King **K**  
 Aurea eco-leather / Ecopelle Aurea **E**  
 Blazer fabric / Tessuto Blazer **B**  
 Leather / Pelle **P**  
 Kvadrat fabrics / Tessuti Kvadrat **DK**

Melamine Laquered Cabinets Colors  
 Colori Laccati Mobili Melaminico



Frame colors  
 Colori struttura



Melamine Cabinets Color  
 Colore Mobili Melaminico



Laminated top color  
 Colori piano laminato

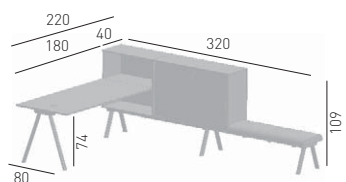

Unassembled structure, individual modules assembled.  
 Struttura non assemblata, singoli moduli assemblati.



1,14 m<sup>3</sup>  
 122,1 kg.

Finishing & Codes / Finiture e Codici

Melamine Cabinets / Mobili in Melaminico

cod. WRKMD1SP.00-00-_(K)/PK__	€	2976,00
cod. WRKMD1SP.00-00-_(E)/PK__	€	2976,00
cod. WRKMD1SP.00-00-_(B)/PK__	€	3069,00
cod. WRKMD1SP.00-00-_(P)/PK__	€	3351,00
cod. WRKMD1SP.00-00-_(DK)/PK__	€	3351,00

Melamine Laquered Cabinets / Mobili in Melaminico Laccato

cod. WRKQD1SP.__-00-_(K)/PK__	€	3860,00
cod. WRKQD1SP.__-00-_(E)/PK__	€	3860,00
cod. WRKQD1SP.__-00-_(B)/PK__	€	3954,00
cod. WRKQD1SP.__-00-_(P)/PK__	€	4047,00
cod. WRKQD1SP.__-00-_(DK)/PK__	€	4047,00

## WORKSTATION 2027 DX VERSION 240 WITH BENCH



Workstation with 2027 structure, cabinet consisting of module with sliding doors and lock, 1 partition and 1 shelf per compartment, open module with 1 shelf. Straight desktop white colour, thickness 22mm. Bench module with padded and upholstered seats.

Stazione di lavoro con struttura 2027, mobile composto da modulo con ante scorrevoli e serratura, 1 tramezza e 1 ripiano per vano, modulo a giorno con 1 ripiano. Piano scrivania di lavoro diritta di colore bianco, spessore 22mm. Modulo panca con sedute imbottite e tappezzate.

BENCH module available coverings / Finiture disponibili modulo panca  
 King fabric / Tessuto King **K**  
 Aurea eco-leather / Ecopelle Aurea **E**  
 Blazer fabric / Tessuto Blazer **B**  
 Leather / Pelle **P**  
 Kvadrat fabrics / Tessuti Kvadrat **DK**

Melamine Laquered Cabinets Colors  
 Colori Laccati Mobili Melaminico



Frame colors  
 Colori struttura



Melamine Cabinets Color  
 Colore Mobili Melaminico



Laminated top color  
 Colori piano laminato

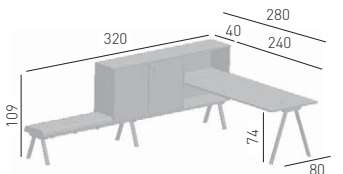

Unassembled structure, individual modules assembled.  
 Struttura non assemblata, singoli moduli assemblati.



1,14 m<sup>3</sup>  
 132,1 kg.

Finishing & Codes / Finiture e Codici

Melamine Cabinets / Mobili in Melaminico

cod. WRKMD2DP.00-00-\_(K)/PK\_ € 3227,00  
 cod. WRKMD2DP.00-00-\_(E)/PK\_ € 3227,00  
 cod. WRKMD2DP.00-00-\_(B)/PK\_ € 3322,00  
 cod. WRKMD2DP.00-00-\_(P)/PK\_ € 3415,00  
 cod. WRKMD2DP.00-00-\_(DK)/PK\_ € 3415,00

Melamine Laquered Cabinets / Mobili in Melaminico Laccato

cod. WRKQD2DP. \_\_-00-\_(K)/PK\_ € 4101,00  
 cod. WRKQD2DP. \_\_-00-\_(E)/PK\_ € 4101,00  
 cod. WRKQD2DP. \_\_-00-\_(B)/PK\_ € 4194,00  
 cod. WRKQD2DP. \_\_-00-\_(P)/PK\_ € 4289,00  
 cod. WRKQD2DP. \_\_-00-\_(DK)/PK\_ € 4289,00

## WORKSTATION 2027 SX VERSION 240 WITH BENCH



Workstation with 2027 structure, cabinet consisting of module with sliding doors and lock, 1 partition and 1 shelf per compartment, open module with 1 shelf. Straight desktop white colour, thickness 22mm. Bench module with padded and upholstered seats.

Stazione di lavoro con struttura 2027, mobile composto da modulo con ante scorrevoli e serratura, 1 tramezza e 1 ripiano per vano, modulo a giorno con 1 ripiano. Piano scrivania di lavoro diritta di colore bianco, spessore 22mm. Modulo panca con sedute imbottite e tappezzate.

BENCH module available coverings / Finiture disponibili modulo panca  
 King fabric / Tessuto King **K**  
 Aurea eco-leather / Ecopelle Aurea **E**  
 Blazer fabric / Tessuto Blazer **B**  
 Leather / Pelle **P**  
 Kvadrat fabrics / Tessuti Kvadrat **DK**

Melamine Laquered Cabinets Colors  
 Colori Laccati Mobili Melaminico



Frame colors  
 Colori struttura



Melamine Cabinets Color  
 Colore Mobili Melaminico



Laminated top color  
 Colori piano laminato

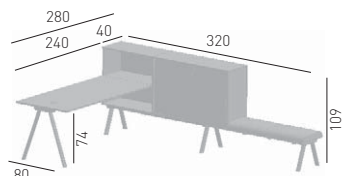

Unassembled structure, individual modules assembled.  
 Struttura non assemblata, singoli moduli assemblati.



1,14 m<sup>3</sup>  
 132,1 kg.

Finishing & Codes / Finiture e Codici

Melamine Cabinets / Mobili in Melaminico

cod. WRKMD2SP.00-00-\_(K)/PK\_ € 3227,00  
 cod. WRKMD2SP.00-00-\_(E)/PK\_ € 3227,00  
 cod. WRKMD2SP.00-00-\_(B)/PK\_ € 3322,00  
 cod. WRKMD2SP.00-00-\_(P)/PK\_ € 3415,00  
 cod. WRKMD2SP.00-00-\_(DK)/PK\_ € 3415,00

Melamine Laquered Cabinets / Mobili in Melaminico Laccato

cod. WRKQD2SP. \_\_-00-\_(K)/PK\_ € 4101,00  
 cod. WRKQD2SP. \_\_-00-\_(E)/PK\_ € 4101,00  
 cod. WRKQD2SP. \_\_-00-\_(B)/PK\_ € 4194,00  
 cod. WRKQD2SP. \_\_-00-\_(P)/PK\_ € 4289,00  
 cod. WRKQD2SP. \_\_-00-\_(DK)/PK\_ € 4289,00

## WORKSTATION 2027 X VERSION 180



Double workstation with 2027 structure, 2 cabinets consisting of modules with sliding doors and lock, 1 partition and 1 shelf per compartment, 1 open module with 1 shelf. Straight desktop white colour, thickness 22mm.

Stazione di lavoro doppia con struttura 2027, 2 mobili composto da moduli con ante scorrevoli e serratura, 1 tramezza e 1 ripiano per vano, 1 modulo a giorno con 1 ripiano. Piani scrivania di lavoro diritti di colore bianco, spessore 22mm.

Melamine Laquered Cabinets Colors  
Colori Laccati Mobili Melaminico

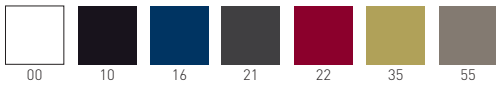

Frame colors  
Colori struttura

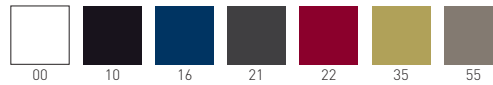

Melamine Cabinets Color  
Colore Mobili Melaminico



Laminated top color  
Colori piano laminato

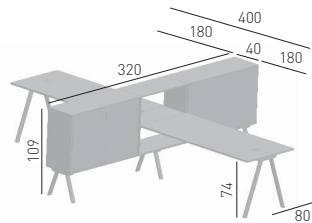

Unassembled structure, individual modules assembled.  
Struttura non assemblata, singoli moduli assemblati.



1,75 m<sup>3</sup>  
188,1 kg.

Finishing & Codes / Finiture e Codici

Melamine Cabinets / Mobili in Melaminico

cod. **WRKMX1.00-00/PK\_\_**

Melamine Laquered Cabinets / Mobili in Melaminico Laccato

cod. **WRKQX1.\_\_-00/PK\_\_**

€ **4165,00**

€ **5535,00**

## WORKSTATION 2027 X VERSION 240



Double workstation with 2027 structure, 2 cabinets consisting of modules with sliding doors and lock, 1 partition and 1 shelf per compartment, 1 open module with 1 shelf. Straight desktop white colour, thickness 22mm.

Stazione di lavoro doppia con struttura 2027, 2 mobili composto da moduli con ante scorrevoli e serratura, 1 tramezza e 1 ripiano per vano, 1 modulo a giorno con 1 ripiano. Piani scrivania di lavoro diritti di colore bianco, spessore 22mm.

Melamine Laquered Cabinets Colors  
Colori Laccati Mobili Melaminico



Frame colors  
Colori struttura



Melamine Cabinets Color  
Colore Mobili Melaminico



Laminated top color  
Colori piano laminato

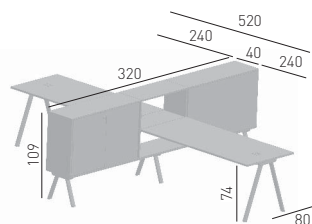

Unassembled structure, individual modules assembled.  
Struttura non assemblata, singoli moduli assemblati.



1,79 m<sup>3</sup>  
208,1 kg.

Finishing & Codes / Finiture e Codici

Melamine Cabinets / Mobili in Melaminico

cod. **WRKMX2.00-00/PK\_\_**

Melamine Laquered Cabinets / Mobili in Melaminico Laccato

cod. **WRKQX2.\_\_-00/PK\_\_**

€ **4672,00**

€ **6158,00**

# Cabinets



To store files and folders in a world of colours. These filing cabinets are suspended, on frames, for easy obstruction-free cleaning. The cabinets themselves, tough and resistant, come with quick and effective assembly fixings. Drawers: On castors and fitted, these simple pieces help keep workspaces tidy and stationary in place.

Per contenere, archiviare e classificare, in un mondo a colori. I mobili contenitori sono sospesi, su strutture a cavalletto, per una semplice pulizia anche automatica. Le strutture, solide e resistenti, sono provviste di sistemi di assemblaggio veloci e sicuri.

Cassettiere: Su ruote e attrezzate, questi semplici complementi aiutano a contenere e ordinare le piccole necessità dell'ufficio.

## Finishings / Finiture

Melamine Laquered Cabinets Colors  
(Antibacterial water-base laquering)  
Colori Laccati Mobili Melaminico  
(Laccatura antibatterica a base acqua)

Frame colors  
Colori struttura

Melamine Cabinets Color  
Colore Mobili Melaminico

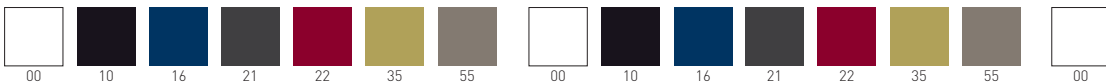

White Matte Laquered Neve (00) / Black Matte Laquered (10) / Blue Matte Laquered 5003 (16) / Grey Matte Laquered Antracite (21) / Bordeaux Matte Laquered 3004 (22)  
Lime Matte Laquered Limone (35) / Mineral Grey Matte Laquered 7006 (55)

## LOW CABINET 2027



Cabinet consisting of 2027 structure, 1 module with sliding doors and lock, 1 partition and 1 shelf per compartment, module with 2 filing cabinets. On request it is possible to replace the module with two filing cabinets with two drawers module. Maximum load on each sliding filing cabinet Kg. 20.

Mobile composto da struttura 2027, modulo con ante scorrevoli e serratura, 1 tramezza e 1 ripiano per vano, modulo con 2 classificatori. Su richiesta, è possibile sostituire il modulo a due classificatori con il modulo a due cassetti estraibili. Carico massimo su ogni classificatore estraibile Kg.20.

Melamine Laquered Cabinets Colors  
Colori Laccati Mobili Melaminico



Frame colors  
Colori struttura

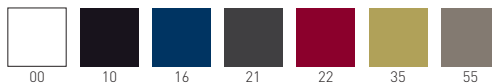

Melamine Cabinets Color  
Colore Mobili Melaminico

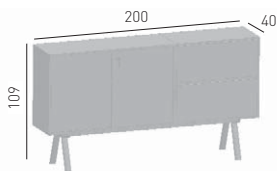

Unassembled structure, individual modules assembled.  
Struttura non assemblata, singoli moduli assemblati.



0,84 m<sup>3</sup>  
96,4 kg.

Finishing & Codes / Finiture e Codici

Melamine Cabinets / Mobili in Melaminico

cod. **CABMLC.00/PK\_\_**

Melamine Laquered Cabinets / Mobili in Melaminico Laccato

cod. **CABQLC.\_\_/PK\_\_**

€ **2370,00**

€ **3337,00**

## CABINET 2027



Cabinet consisting of 2027 structure and module with sliding doors and lock, 1 Partition and 2 shelves per compartment.

Mobile composto da struttura 2027 e modulo con ante scorrevoli e serratura, 1 tramezza e 2 ripiani per vano.

Melamine Laquered Cabinets Colors  
Colori Laccati Mobili Melaminico



Frame colors  
Colori struttura



Melamine Cabinets Color  
Colore Mobili Melaminico

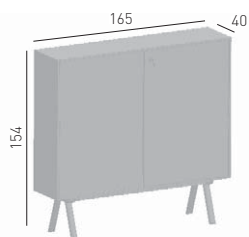

Unassembled structure, individual modules assembled.  
Struttura non assemblata, singoli moduli assemblati.



1,03 m<sup>3</sup>  
87,9 kg.

Finishing & Codes / Finiture e Codici

Melamine Cabinets / Mobili in Melaminico

cod. **CABMCC.00/PK\_\_**

Melamine Laquered Cabinets / Mobili in Melaminico Laccato

cod. **CABQCC.\_\_/PK\_\_**

€ **1796,00**

€ **3018,00**



## MULTIPLE CABINET 2027



Cabinet consisting of 2027 structure and two modules with sliding doors and lock, 1 Partition and 2 shelves per compartment.

Mobile composto da struttura 2027 e 2 moduli con ante scorrevoli e serratura, 1 tramezza e 2 ripiani per vano.

Melamine Laquered Cabinets Colors  
Colori Laccati Mobili Melaminico

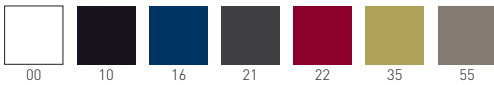

Frame colors  
Colori struttura



Melamine Cabinets Color  
Colore Mobili Melaminico

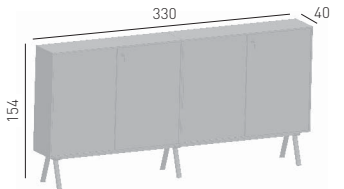

Unassembled structure, individual modules assembled.  
Struttura non assemblata, singoli moduli assemblati.



2,01 m<sup>3</sup>  
163,9 kg.

Finishing & Codes / Finiture e Codici

Melamine Cabinets / Mobili in Melaminico

cod. CABMMC.00/PK\_\_

Melamine Laquered Cabinets / Mobili in Melaminico Laccato

cod. CABQMC.\_\_/PK\_\_

€ 3556,00

€ 5999,00

## HIGH CABINET 2027



Cabinet consisting of 2027 structure, two modules with sliding doors and locks, 1 partition and 1 shelf per compartment, module with 2 filing cabinets, open module with 1 shelf. On request it is possible to replace the module with two filing cabinets with two drawers module. Maximum load on each sliding filing cabinet Kg. 20.

Mobile composto da struttura 2027, due moduli con ante scorrevoli e serrature, 1 tramezza e 1 ripiano per vano, modulo con 2 classificatori, modulo a giorno con 1 ripiano. Su richiesta, è possibile sostituire il modulo a due classificatori con il modulo a due cassetti estraibili. Carico massimo su ogni classificatore estraibile Kg.20.

Melamine Laquered Cabinets Colors  
Colori Laccati Mobili Melaminico



Frame colors  
Colori struttura



Melamine Cabinets Color  
Colore Mobili Melaminico

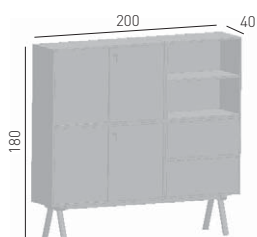

Unassembled structure, individual modules assembled.  
Struttura non assemblata, singoli moduli assemblati.



1,54 m<sup>3</sup>  
161,4 kg.

Finishing & Codes / Finiture e Codici

Melamine Cabinets / Mobili in Melaminico

cod. CABMHC.00/PK\_\_

Melamine Laquered Cabinets / Mobili in Melaminico Laccato

cod. CABQHC.\_\_/PK\_\_

€ 3739,00

€ 5670,00

## LOW CABINET 2027 + SEATER



Cabinet consisting of 2027 structure, 1 module with sliding doors and lock, 1 partition and 1 shelf per compartment, upholstered service seats.

Mobile composto da struttura 2027, modulo con ante scorrevoli e serratura, 1 tramezza e 1 ripiano per vano, sedute imbottite di servizio.

BENCH module available coverings / Finiture disponibili modulo panca

King fabric / Tessuto King **K**

Aurea eco-leather / Ecopelle Aurea **E**

Blazer fabric / Tessuto Blazer **B**

Leather / Pelle **P**

Kvadrat fabrics / Tessuti Kvadrat **DK**

Melamine Laquered Cabinets Colors  
Colori Laccati Mobili Melaminico



Frame colors  
Colori struttura



Melamine Cabinets Color  
Colore Mobili Melaminico

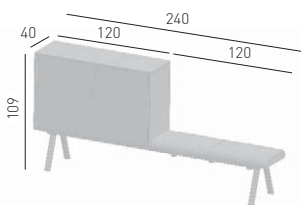

Unassembled structure, individual modules assembled.  
Struttura non assemblata, singoli moduli assemblati.



0,55 m<sup>3</sup>  
61,90 kg.

Finishing & Codes / Finiture e Codici

Melamine Cabinets / Mobili in Melaminico

cod. CABMLP.00-\_(K)\_\_\_/PK\_\_\_

cod. CABMLP.00-\_(E)\_\_\_/PK\_\_\_

cod. CABMLP.00-\_(B)\_\_\_/PK\_\_\_

cod. CABMLP.00-\_(P)\_\_\_/PK\_\_\_

cod. CABMLP.00-\_(DK)\_\_\_/PK\_\_\_

Melamine Laquered Cabinets / Mobili in Melaminico Laccato

cod. CABQLP.\_\_\_\_\_(K)\_\_\_/PK\_\_\_

cod. CABQLP.\_\_\_\_\_(E)\_\_\_/PK\_\_\_

cod. CABQLP.\_\_\_\_\_(B)\_\_\_/PK\_\_\_

cod. CABQLP.\_\_\_\_\_(P)\_\_\_/PK\_\_\_

cod. CABQLP.\_\_\_\_\_(DK)\_\_\_/PK\_\_\_

€ 1857,00

€ 1857,00

€ 1950,00

€ 2044,00

€ 2044,00

€ 2404,00

€ 2404,00

€ 2499,00

€ 2592,00

€ 2592,00

## DRAWER

Drawer on rubber wheels with lock. 3 drawers plus office product bin.  
Cassetiera su ruote gommiate con serratura. 3 cassetti più portacancelleria.



Melamine Laquered Drawer Colors  
Colori Laccati Cassetiera Melaminico

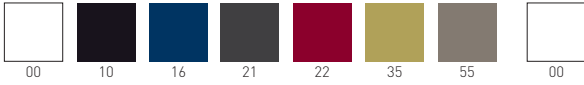

Melamine Drawer Color  
Colore Cassetiera Melaminico

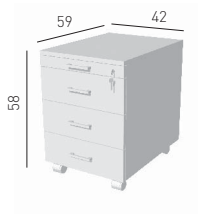

A assembled / assemblata



0,16 m<sup>3</sup>  
28 kg.

Finishing & Codes / Finiture e Codici

Melamine Cabinets / Mobili in Melaminico

cod. **CABMDR.00/A**

Melamine Laquered Cabinets / Mobili in Melaminico Laccato

cod. **CABQDR.\_\_/A**

€ **560,00**

€ **882,00**



Display wall or floor fixed storage shelving can enhance your most ambitious projects. Available with a black, gold or white matt painted steel frame, without any visible welds, Display is set off with solid Fenix laminate shelves. Display is a modular piece, which can support up to 4 shelves and lends itself to completing and finely decorating walls and corners of your commercial spaces. For correct use, the structure must be fixed to the wall or floor.

Semplice ed elegante, Display decorerà con discrezione i vostri progetti più ambiziosi. Disponibile con struttura in acciaio verniciato nero, oro o bianco opaco, senza nessuna saldatura a vista, è impreziosito da solidi ripiani in laminato Fenix. Display è un elemento modulare, che può sostenere sino a 4 mensole e si presta a completare e decorare con raffinatezza pareti ed angoli dei vostri spazi commerciali. Per un corretto utilizzo, questo mobile deve essere fissato alla parete o pavimento.

#### Finishings / Finiture

##### Frame colors / Colori struttura



00

10

GOLD

##### Fenix laminated top color / Colori piano laminato Fenix

0029  
Fenix0720  
Fenix

## DISPLAY



Frame colors / Colori struttura

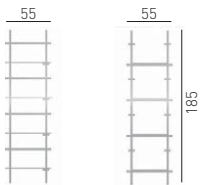

Single metal frame "Display", matt painted.  
Struttura singola in metallo verniciato opaco "Display"

NA not assembled / non assemblato



0,63 m<sup>3</sup> - 22 kg.  
55x55x185cm.  
1 pcs [carton]

Frame Finishing & Codes / Finiture Telai e Codici

**cod. ACCV020.\_\_\_\_**

€ **1011,00**

Fenix laminated top color / Colori piano laminato Fenix

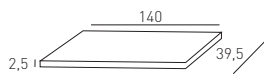
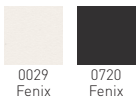

Laminated shelve "Display".  
Mensola in laminato "Display"

NA not assembled / non assemblato



0,16 m<sup>3</sup> - 9,50 kg.  
1 pcs [carton]

Frame Finishing & Codes / Finiture Telai e Codici

**Cod. PTL460.\_\_\_\_ lam.fenix**

€ **358,00**

## DISPLAY EXAMPLE OF USE



# ACOUSTIC Collection



# Stilly

Collection certified UNI EN ISO 354:2003, sound absorption A Class following UNI EN ISO 11654:1998. The Collection is certified ASTM E84-16 for surface burning characteristics of building materials (UL723, UBC 8-1, NFPA 255). The collection is certified Class 1 Reaction to Fire following UNI 8457:1987-UNI 8457/A1:1996 and UNI 9174:1987-UNI 9174/A1:1996. Collezione certificata UNI EN ISO 354:2003, Classe A di assorbimento acustico secondo la norma UNI EN ISO 11654: 1998. La collezione è certificata ASTM E84-16 secondo le caratteristiche di resistenza al fuoco dei materiali da costruzione (UL723, UBC 8-1, NFPA 255). La collezione è certificata Classe 1 seguendo le norme UNI 8457:1987-UNI 8457/A1:1996 and UNI 9174:1987-UNI 9174/A1:1996 per la resistenza al fuoco.

#### Standard colors Colori standard



On demand, minimum 52 pcs - surcharge 28 € each unit  
Gestione su commessa quantità minima 52 pz - prezzo 28 € per unità

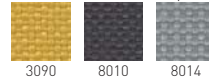

### STILLY FLAT

Sound-absorbing system.  
Sistema di pannelli fonoassorbenti.

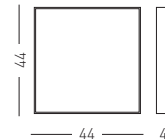

0,040 m<sup>3</sup> - 2,95 kg.  
47x45x19cm.  
4 pcs [carton]

Finishing & Codes / Finiture e Codici

**cod.PASTF.--**  
**cod.PASTFB.--** led version

€ **65,00**  
€ **233,00**

### STILLY PYRAMID

Sound-absorbing system.  
Sistema di pannelli fonoassorbenti.

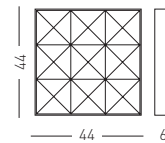

0,040 m<sup>3</sup> - 2,95 kg.  
47x45x19cm.  
4 pcs [carton]

Finishing & Codes / Finiture e Codici

**cod.PASTP.--**  
**cod.PASTPB.--** led version

€ **65,00**  
€ **233,00**

# Fono



Standard colors  
Colori standard

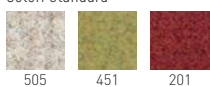

505 451 201

## FONO A

Sound-absorbing system.  
Sistema di pannelli fonoassorbenti.

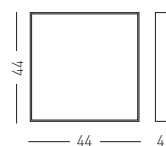

0,040 m<sup>3</sup> - 2,95 kg.  
47x45x19cm.  
4 pcs [carton]

Finishing & Codes / Finiture e Codici

cod.PAFOA.--

€ **74,00**

## FONO B

Sound-absorbing system.  
Sistema di pannelli fonoassorbenti.

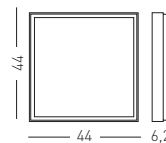

0,055 m<sup>3</sup> - 3,20 kg.  
47x45x26cm.  
4 pcs [carton]

Finishing & Codes / Finiture e Codici

cod.PAFOB.--

€ **74,00**



## FONO C

Sound-absorbing system.  
Sistema di pannelli fonoassorbenti.

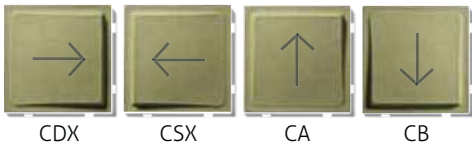

CDX

CSX

CA

CB

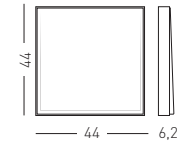

0,047 m<sup>3</sup> - 3,10 kg.  
47x45x22cm.  
4 pcs [carton]

Finishing & Codes / Finiture e Codici

cod.PAFOCA.--  
cod.PAFOCB.--  
cod.PAFOCDX.--  
cod.PAFOCSX.--

€ 74,00  
€ 74,00  
€ 74,00  
€ 74,00

## FONO D

Sound-absorbing system.  
Sistema di pannelli fonoassorbenti.



DDX

DSX

DA

DB

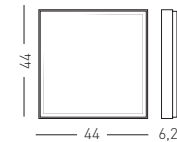

0,047 m<sup>3</sup> - 3,10 kg.  
47x45x22cm.  
4 pcs [carton]

Finishing & Codes / Finiture e Codici

cod.PAFODA.--  
cod.PAFODB.--  
cod.PAFODDX.--  
cod.PAFODSX.--

€ 74,00  
€ 74,00  
€ 74,00  
€ 74,00



Collection certified UNI EN ISO 354:2003, sound absorption C Class following UNI EN ISO 11654:1998.  
 Collezione certificata UNI EN ISO 354:2003, Classe C di assorbimento acustico secondo la norma UNI EN ISO 11654: 1998.

### UNIKO FLAT

Sound-absorbing system for false ceiling.  
 Sistema di pannelli fonoassorbenti per controsoffitti.

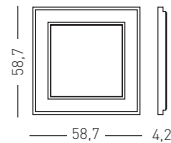

Finishing & Codes / Finiture e Codici

**cod.PAUKF.--**

€ **82,00**



0,060 m<sup>3</sup> - 3,7 kg.  
 61x61x16cm.  
 3 pcs [carton]

Standard colors / Colori standard

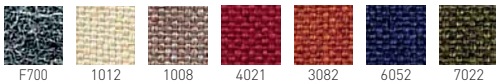

### UNIKO PIRAMID

Sound-absorbing system for false ceiling.  
 Sistema di pannelli fonoassorbenti per controsoffitti.

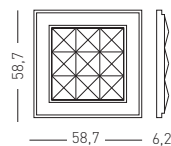

Finishing & Codes / Finiture e Codici

**cod.PAUKP.--**

€ **82,00**



0,060 m<sup>3</sup> - 3,7 kg.  
 61x61x16cm.  
 3 pcs [carton]

Standard colors / Colori standard

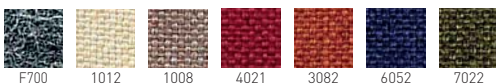

### UNIKO 4

Sound-absorbing system for false ceiling.  
 Sistema di pannelli fonoassorbenti per controsoffitti.

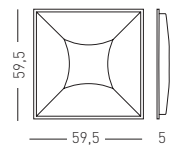

Finishing & Codes / Finiture e Codici

**cod.PAUK4.-- Uniko 4 Coverings**

€ **74,00**



0,060 m<sup>3</sup> - 6,4 kg.  
 61x61x16cm.  
 10 pcs [carton]

Uniko 4 coverings colors / Uniko 4 colori tessuti

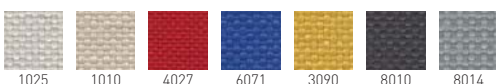

# Madison



Madison 4 coverings colors / Madison 4 colori tessuti



1025 1010 4027 6071 3090 8010 8014

## MADISON 4



Sound-absorbing system for false ceiling.  
Sistema di pannelli fonoassorbenti per controsoffitti.

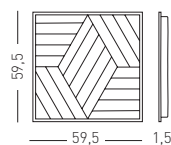

0,060 m<sup>3</sup> - 6,5 kg.  
61x61x16cm.  
10 pcs (carton)

Finishing & Codes / Finiture e Codici

cod.PAMA4.-- Madison 4 Coverings

€ **79,00**

# Diamante

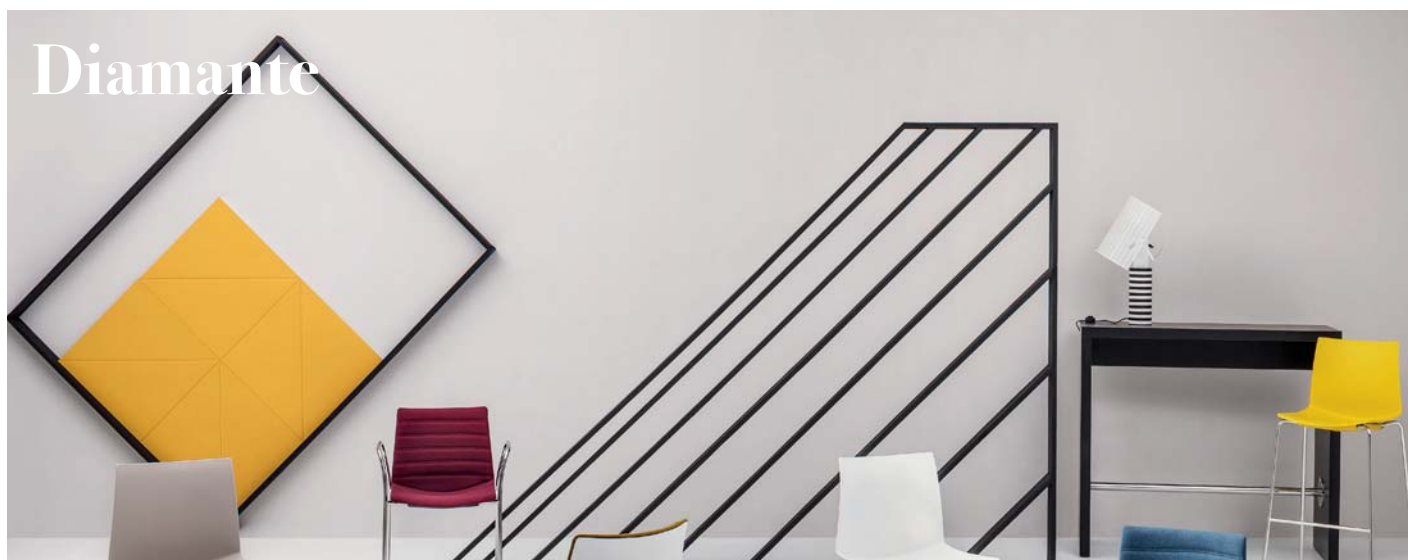

Collection certified UNI EN ISO 354:2003, sound absorption A Class following UNI EN ISO 11654:1998.  
 Collezione certificata UNI EN ISO 354:2003, Classe A di assorbimento acustico secondo la norma UNI EN ISO 11654: 1998.

Diamante 4 / Diamante Double 4 / Diamante Spotlight X2 / X4 Coverings



Frame colors

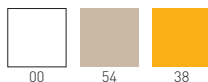

## DIAMANTE 4

Diamante sound-absorbing panels.  
 Pannelli fonoassorbenti Diamante.

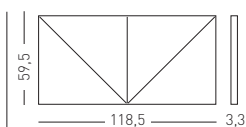

0,11 m<sup>3</sup> - 12 kg.  
 123x62x16cm.  
 4 pcs [carton]

Finishing & Codes / Finiture e Codici

**cod.PADI4.>--** Diamante 4 Coverings

€ **188,00**

Diamante 4 customized printed panel  
 Pannello Diamante 4 personalizzato stampato  
 (min 4pcs)

€ **597,00**

## DIAMANTE DOUBLE 4

Diamante sound-absorbing panels  
 with double coverings.  
 Pannelli fonoassorbenti Diamante con  
 doppia copertura.

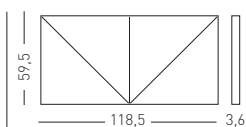

0,12 m<sup>3</sup> - 15,7 kg.  
 123x62x16cm.  
 4 pcs [carton]

Finishing & Codes / Finiture e Codici

**cod.PADI4D.--** Diamante Double 4 Coverings

€ **273,00**

Diamante 4 Double customized printed panel  
 Pannello Diamante 4 Double personalizzato  
 stampato (min 4pcs)

€ **682,00**

## DIAMANTE SPOTLIGHT X2

Sound-absorbing panel with  
 integrated lighting kit (2 led).  
 Pannello fonoassorbente con kit  
 illuminazione integrato (2 led).



Only with ACCV005 horizontal  
 suspension kit.  
 Solo con ACCV005 kit sospensione  
 orizzontale.

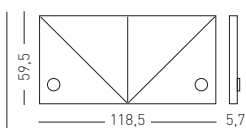

0,12 m<sup>3</sup> - 9 kg.  
 123x62x16cm.  
 2 pcs [carton]

Finishing & Codes / Finiture e Codici

**cod.PADLX2.--**

€ **296,00**

## DIAMANTE SPOTLIGHT X4



Sound-absorbing panel with integrated lighting kit (4 led).  
Pannello fonoassorbente con kit illuminazione integrato (4 led).

Only with ACCV005 horizontal suspension kit.  
Solo con ACCV005 kit sospensione orizzontale.

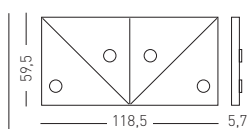

0,12 m<sup>3</sup> - 9 kg.  
123x62x16cm.  
2 pcs [carton]

Finishing & Codes / Finiture e Codici

cod.PADLX4.--

€ 406,00

## DIAMANTE VERTICAL SUSPENSION

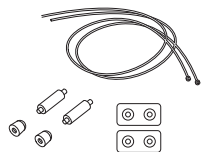

Vertical suspension optional kit, length 3m.  
Kit opzionale sospensione verticale, lunghezza 3m.

Codes / Codici

ACCV004

€ 54,00

## DIAMANTE HORIZONTAL SUSPENSION

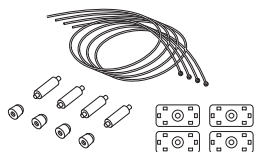

Horizontal suspension optional kit, length 3m.  
Kit opzionale sospensione orizzontale, lunghezza 3m.

Codes / Codici

ACCV005

€ 143,00

## DIAMANTE PEDESTAL

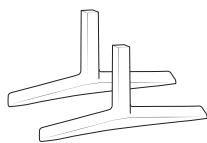

2 white legs pedestal optional kit.  
Kit opzionale 2 gambe piedistallo bianche.

Codes / Codici

ACCV006.00 white/bianco

€ 34,00

## DIAMANTE PARTITION LEG



Screen partition optional kit.  
Kit opzionale divisorio.

Codes / Codici

ACCV007

€ 85,00

## DIAMANTE WALL FIXING

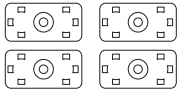

Wall fixing optional kit.  
Kit opzionale fissaggio a parete.

Codes / Codici

ACCV008

€ 62,00

## DIAMANTE LIGHTING SYSTEM

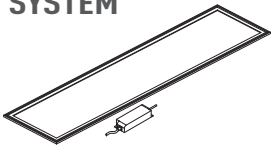

Horizontal suspension lighting system kit.  
Kit di illuminazione per sospensione orizzontale.

Codes / Codici

ACCV009

€ 440,00



## DIAMANTE PARTITION A

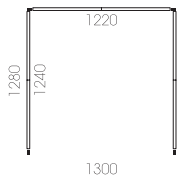

0,50 m<sup>3</sup> - 32 kg.  
1 pcs [carton]

Finishing & Codes / Finiture e Codici

cod.PAPADA.--

€ 1978,00

## DIAMANTE PARTITION B

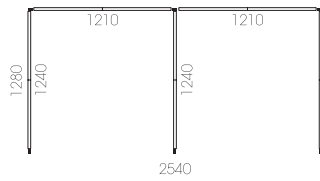

0,60 m<sup>3</sup> - 52 kg.  
1 pcs [carton]

Finishing & Codes / Finiture e Codici

cod.PAPADB.--

€ 3240,00

## DIAMANTE PARTITION C

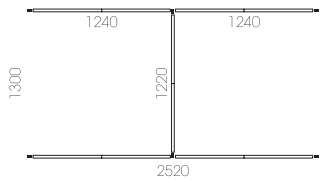

0,60 m<sup>3</sup> - 52 kg.  
1 pcs [carton]

Finishing & Codes / Finiture e Codici

cod.PAPADC.--

€ 3240,00

## DIAMANTE PARTITION D

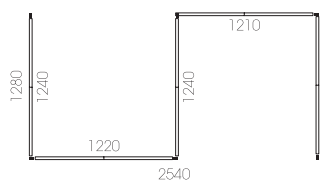

0,60 m<sup>3</sup> - 52 kg.  
1 pcs [carton]

Finishing & Codes / Finiture e Codici

cod.PAPADD.--

€ 3240,00

## DIAMANTE PARTITION E

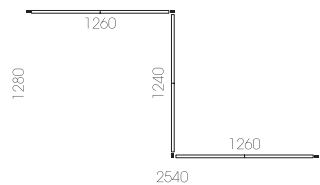

0,50 m<sup>3</sup> - 32 kg.  
1 pcs [carton]

Finishing & Codes / Finiture e Codici

cod.PAPADE.--

€ 1978,00

## DIAMANTE PARTITION F

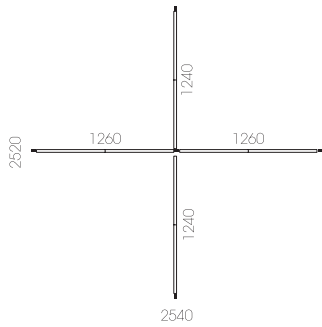

0,50 m<sup>3</sup> - 44 kg.  
1 pcs [carton]

Finishing & Codes / Finiture e Codici

cod.PAPADF.--

€ 2609,00

## DIAMANTE PARTITION A2

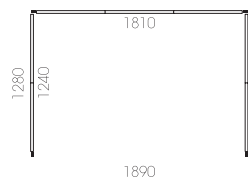

0,50 m<sup>3</sup> - 36 kg.  
1 pcs [carton]

Finishing & Codes / Finiture e Codici

cod.PAPADA2.--

€ 2251,00

## DIAMANTE PARTITION B2

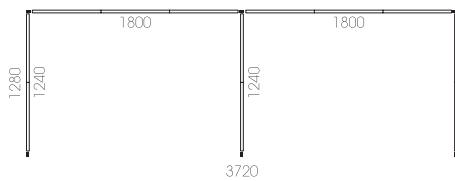

0,60 m<sup>3</sup> - 60 kg.  
1 pcs [carton]

Finishing & Codes / Finiture e Codici

cod.PAPAB2.--

€ 3785,00

## DIAMANTE PARTITION C2

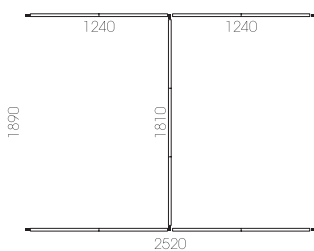

0,60 m<sup>3</sup> - 56 kg.  
1 pcs [carton]

Finishing & Codes / Finiture e Codici

cod.PAPADC2.--

€ 3512,00

## DIAMANTE PARTITION D2

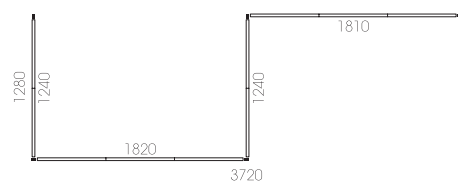

0,60 m<sup>3</sup> - 60 kg.  
1 pcs [carton]

Finishing & Codes / Finiture e Codici

cod.PAPADD2.--

€ 3785,00



# Piuma



Collection certified UNI EN ISO 354:2003, sound absorption A Class following UNI EN ISO 11654:1998.  
 Collezione certificata UNI EN ISO 354:2003, Classe A di assorbimento acustico secondo la norma UNI EN ISO 11654: 1998.

Standard colors  
 Colori standard

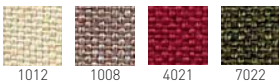

## PIUMA 55

Sound-absorbing system.  
 Sistema di pannelli fonoassorbenti.

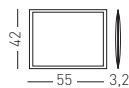

0,06 m<sup>3</sup> - 4 kg.  
 45x80x16cm.  
 4 pcs [carton]

Finishing & Codes / Finiture e Codici

cod.PAPI55.\_\_\_\_

€ **147,00**

## PIUMA 65



Sound-absorbing system.  
Sistema di pannelli fonoassorbenti.

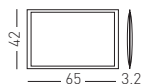

0,06 m<sup>3</sup> - 5 kg.  
45x80x16cm.  
4 pcs [carton]

Finishing & Codes / Finiture e Codici

cod.PAPI65.\_\_\_\_

€ **153,00**

## PIUMA 75



Sound-absorbing system.  
Sistema di pannelli fonoassorbenti.

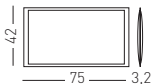

0,06 m<sup>3</sup> - 6 kg.  
45x80x16cm.  
4 pcs [carton]

Finishing & Codes / Finiture e Codici

cod.PAPI75.\_\_\_\_

€ **160,00**

## PIUMA 150



Sound-absorbing system.  
Sistema di pannelli fonoassorbenti.

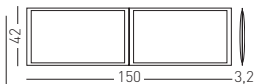

0,13 m<sup>3</sup> - 12 kg.  
45x80x35cm.  
4 pcs [carton]

Finishing & Codes / Finiture e Codici

cod.PAPI150.\_\_\_\_

€ **319,00**

## PIUMA BRACKET



Piuma bracket support, adjustable till 64mm table thickness.  
Staffa di fissaggio pannello Piuma, regolabile sino ad uno spessore tavolo di 64mm.



Included on Piuma panels packaging.  
Inclusa nell'imballo pannelli Piuma.

Finishing & Codes / Finiture e Codici

cod.ACCV016.00 white/bianco

€ **56,00**

# TUNE Free-Standing



The sound-absorbing free-standing panels of the Tune collection are designed both to furnish with elegance as well as to assure the precise function of reducing sound reverberation. Equipped with a matt painted metal base, they are made of polyester fiber and available in two different sizes.

I pannelli fonoassorbenti free-standing della famiglia Tune sono pensati per arredare con eleganza, nella precisa funzione di ridurre il riverbero sonoro. Dotati di basamento in metallo verniciato opaco, sono realizzati in fibra di poliestere e disponibili in due diverse dimensioni.

## Finishings / Finiture

### Frame colors / Colori struttura

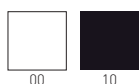

### Standard colors / Colori standard

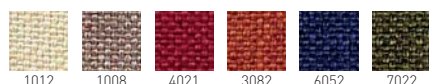

## TUNE FREE-STANDING 80



### Frame colors / Colori struttura

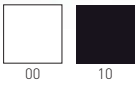

### Standard colors / Colori standard

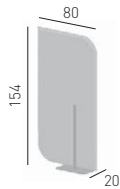

NA not assembled / non assemblato



0,125 m<sup>3</sup> - 15,5 kg.  
159x110x7cm.  
1 pcs [carton]

Frame Finishing & Codes / Finiture Telai e Codici

cod. PATNS80.\_(FRAME)\_-(FABRIC)\_

€ **752,00**

## TUNE FREE-STANDING 100



### Frame colors / Colori struttura

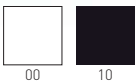

### Standard colors / Colori standard

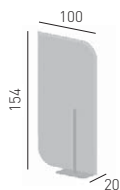
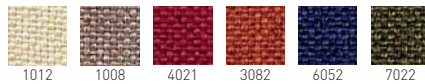

NA not assembled / non assemblato



0,125 m<sup>3</sup> - 16,5 kg.  
159x110x7cm.  
1 pcs [carton]

Frame Finishing & Codes / Finiture Telai e Codici

cod. PATNS100.\_(FRAME)\_-(FABRIC)\_

€ **773,00**

# TUNE Desk Settings



The sound-absorbing panels of the Tune collection fixed to the desk tops are practical screens to enhance privacy, improving acoustic comfort, facilitating concentration and well-being in the workplace.

I pannelli fonoassorbenti della famiglia Tune fissati ai piani delle scrivanie come pratici schermi per valorizzare la privacy, migliorano il comfort acustico, agevolando la concentrazione e il benessere nell'ambito degli ambienti di lavoro.

## Finishings / Finiture

Bracket color / Colore staffa fissaggio



00

Standard colors / Colori standard



1012

1008

4021

3082

6052

7022

## TUNE DESK SETTINGS 80



"Tune" acoustic panel, with white bracket kit for desk settings.  
Pannello Fonoassorbente "Tune", con kit staffe fissaggio a scrivania colore bianco.

Bracket color / Colore staffa fissaggio



00

Standard colors / Colori standard

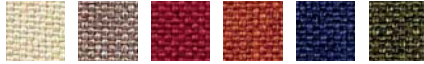

1012

1008

4021

3082

6052

7022

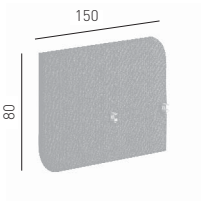

NA not assembled / non assemblato



0,125 m<sup>3</sup> - 10 kg.  
159x110x7cm.  
1 pcs [carton]

Frame Finishing & Codes / Finiture Telai e Codici

cod. PATND80.00-\_\_\_\_\_

€ **594,00**

# Onda



## Finishing Finiture



## ONDA



Onda fills of persona-lity any environments, decorating and lighting them, even improving acoustic comfort.

Onda riempie di carattere gli ambienti, decorandoli, illuminandoli e fungendo anche da elemento fonoassorbente.

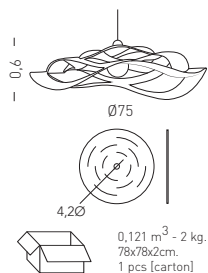

## Finishing & Codes / Finiture e Codici

cod.LAON2.FB-F700  
cod.LAON2.FB-F032  
cod.LAON2.FB-F065

€ 273,00  
€ 273,00  
€ 273,00

## ACCESSORIES

White Lamp Holder.  
Portalampada Bianco.



## Finishing & Codes / Finiture e Codici

ACCV003

€ 34,00

# Culture

Malene Flensted Urup Design



Ø50 or Ø70 cm aluminum planter, black painted, complete with suspension column, available in customize length between 100cm to 240cm.

Vaso in alluminio Ø50 o Ø70 cm, verniciato nero, completo di colonna di sospensione, disponibile in lunghezze personalizzate da 100cm a 240cm

Frame Color / Colore Struttura



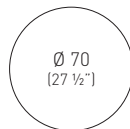
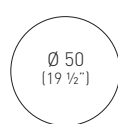
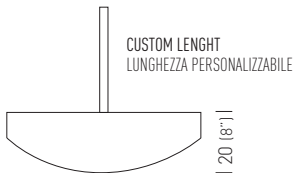

10



diam.50  
diam.70

1500/NAN  
1501/NAN

 0.20m<sup>3</sup> / 10kg / 1pcs  
 0.20m<sup>3</sup> / 11kg / 1pcs

€ **1238,00**  
€ **1500,00**





# Flaire

Studio Eurolinea Design

Techno-polymer Lamp collection  
with diffused shine effect.

Collezione di lampade in materiale  
plastico con effetto a bagliore diffuso.

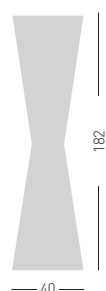

230V - 50Hz  
1 X 16W - Led Modul  
IP 65

Colors / Colori



00

H182

2182/A

0.32m<sup>3</sup> / 15kg / 1pcs

€ **1104,00**

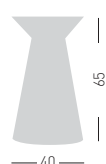

230V - 50Hz  
1 X 16W - Led Modul  
IP 65

Colors / Colori



00

H65

2065/A

0.14m<sup>3</sup> / 12kg / 1pcs

€ **600,00**

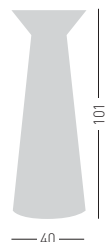

230V - 50Hz  
1 X 16W - Led Modul  
IP 65

Colors / Colori



00

H101

2101/A

0.21m<sup>3</sup> / 14kg / 1pcs

€ **769,00**



# Lux

Studio Eurolinea Design

Anodized aluminum  
and techno-polymer coat-hanger.  
Appendiabiti in alluminio  
anodizzato e tecnopolimero

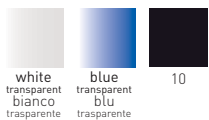

49.--

 0.1m<sup>3</sup> / 11kg / 1pcs

€ **198,00**

white  
transparent  
bianco  
trasparente

blue  
transparent  
blu  
trasparente

10

# ACCESSORIES ACCESSORI

## CHAIR CONNECTIONS / GANCI PER UNIRE LE SEDIE



**1000**  
for models Maya, Tulip and Iris  
per modelli Maya, Tulip e Iris

€ 8,00



**1002**  
for models with frame Ø 16mm  
per modelli con telaio Ø 16mm

€ 8,00



**1001**  
for model Compact  
per modello Compact

€ 8,00



**1005**  
for Models Kanvas ST  
per modelli Kanvas ST

€ 8,00



All glides  
tutti i tipi di tappi  
€ 2,00

## TABLE LINKING DEVICE / AGGANCIAMENTO PER TAVOLI



**Cod. 1100**  
Metal-Technopolymer Linking device KIT (male+female), suitable for Laminated table tops (22 or 25 mm), complete with screws and pre-drilled holes on table-tops. Not assembled.  
KIT Aggancio in Metallo-Tecnopolimero (maschio+femmina), adatto a piani in Laminato (22 o 25 mm), completo di viti e pre-forature sui piani. Non assemblato.

€ 109,00 1 Kit allow the complete connection between two tables.  
1 Kit permette la connessione completa di due tavoli.

## TABLET STAND / SUPPORTO TABLET

Technopolymer Tablet stand supports all top-selling tablets and smartphones in both portrait or landscape positions.

The tablet stand fit perfectly all Compactop Surfaces, both 11 or 12 mm thick.

Accessorio in tecnopolimero per supportare i più venduti tablet o smartphones, sia in posizione verticale che orizzontale, è utilizzabile su superfici in Compactop, in entrambi gli spessori 11 e 12mm.



Available Color / Colori disponibili



G1



50

36

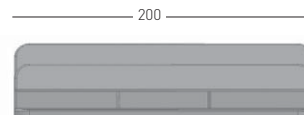

200

cod. 1103.G1 0.005m<sup>3</sup> / 5kg / 50pcs € 12,00

## POWER UNIT / UNITÀ DI ELETTRIFICAZIONE

The Power Unit includes a power socket (Schuko), a USB type A+C port and 2meter connection cable. Thanks to its stand-alone base, the power unit can fixed by screws or can be placed anywhere on the worktop without any limits, allowing the user to get the power wherever is needed. Thanks to a suspension bracket the power unit can be easily mounted upside-down the worksurface, in order to keep free your desk.

Il sistema di elettrificazione da scrivania include una presa energia (Schuko), le porte USB A+C. e due metri di cavo di connessione. La sua base d'appoggio consente di essere fissata con viti o posizionata senza alcun vincolo al piano, offrendo la libertà di utilizzo ovunque ci sia una esigenza di collegamento. Il fissaggio sotto piano per mezzo di un'apposita staffa permette di liberare le superfici d'appoggio, in questo modo si può sfruttare al massimo lo spazio della superficie di lavoro.



Available Color / Colori disponibili



cod. ACCV040.00 white/bianco

cod. ACCV040.10 black/nero

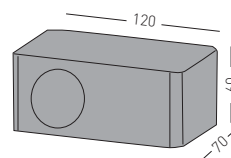

0.06m<sup>3</sup> / 7.5kg / 8pcs

0.06m<sup>3</sup> / 7.5kg / 8pcs

€ 329,00

€ 329,00



## GABER TOOL BOX

The technopolymer Gaber Tool Box is a practical desk organiser. The Tool Box stacks perfectly and is available in a wide range of trendy vibrant color.

Gaber Tool Box è un pratico raccogliitore di oggetti per la scrivania. Il Tool Box si impila perfettamente, ed è disponibile in una vasta gamma di moderni colori.

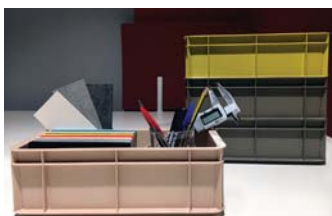

Available Color / Colori disponibili

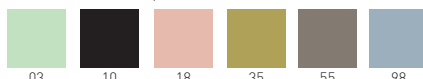

cod. ACCV011.\_\_\_\_



0.015m<sup>3</sup> / 0.6kg / 2pcs

€ 17,00

## GABER CLEANING KIT / KIT DI PULIZIA GABER

Excellent solution in order to keep the best cleaning on table tops, technopolymer chairs and stools, metal, aluminum and wooden surfaces.

Ottima soluzione per mantenere al meglio la pulizia dei piani tavoli, sedie e sgabelli in tecnopolimero, superfici in metallo, legno e alluminio.



ACCV001

0.007m<sup>3</sup> / 0.5kg / 1pcs

€ 31,00

Cleanig liquid + Cloth / Detergente liquido + Panno

# COLOURS AND COVERINGS

## COLORI E RIVESTIMENTI

Techno-polymer / Tecnopolimero



## Metal finishes / Finiture metalli

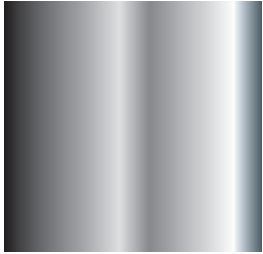

**C**  
Chromed / Cromato



**S**  
Satin / Satinato

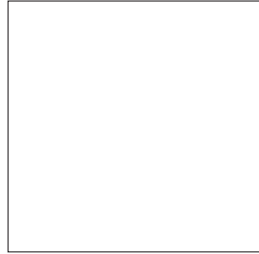

**B**  
White / Bianco



**N**  
Black / Nero



**D**  
Gold / Oro

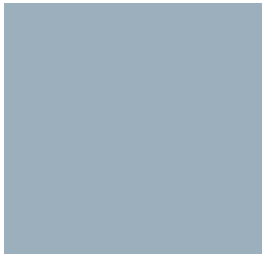

**98**  
Pale blue / Avio



**16**  
Indigo / Indaco



**35**  
Lime / Lime



**02**  
Yellow / Giallo



**06**  
Red / Rosso



**12**  
Brick / Mattone



**22**  
Bordeaux / Bordeaux



**54**  
Sand / Sabbia



**18**  
Dusty Rose / Polvere Rosa

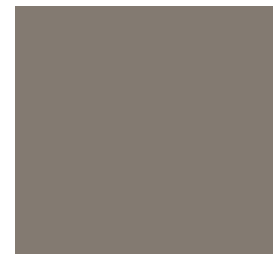

**55**  
Mineral Gray / Grigio Minerale

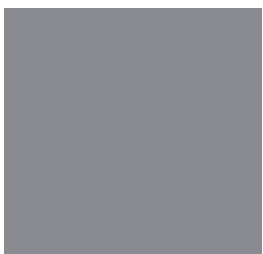

**14**  
Pearl Grey / Grigio Perla



**21**  
Grey / Grigio Antracite

# COLOURS AND COVERINGS

## COLORI E RIVESTIMENTI

Bases and frames wooden finishes / Finiture legno basi e telai



**00 White stained** / Bianco



**F Natural Beech** / Faggio naturale



**RN Natural Oak** / Rovere Naturale



**10 Black stained** / Nero

F-00-10 finishes arise from Beech Essence. RN finish come from Oak Essence  
Le finiture F-00-10 derivano da essenza di Faggio. La finitura RN deriva da essenza di Rovere.

Standard Compactop Surface



00



10



14

Special Compactop Surface Fenix - [www.fenixforinteriors.com](http://www.fenixforinteriors.com)



0029



0720

Special Compactop Surface - Solid - [www.arpaindustriale.com](http://www.arpaindustriale.com)



244



527

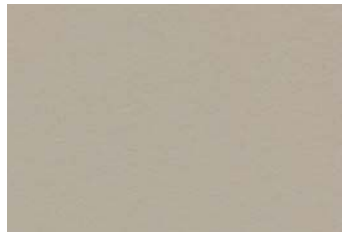

247



526

Special Compactop Surface - Wood Effect - [www.arpaindustriale.com](http://www.arpaindustriale.com)



4529



4543



4587



4511



# COLOURS AND COVERINGS

## COLORI E RIVESTIMENTI

Special Compactop Surface - Stone, Concrete and Marble Effect - [www.arpaindustriale.com](http://www.arpaindustriale.com)



3192



3349



3276



3329



5547

Special Compactop Surface - Marble Effect - [www.lamicolor.it](http://www.lamicolor.it)

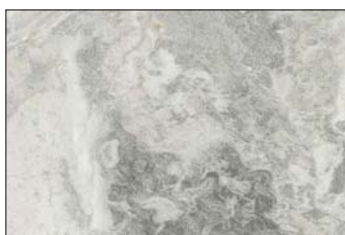

6075

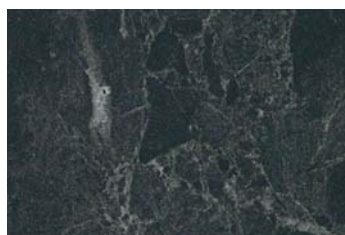

6076

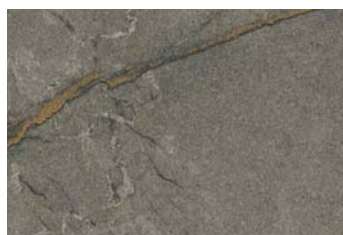

6089

Standard Laminated Surface



F



RN



W

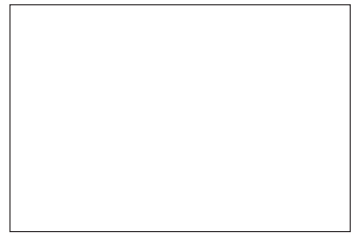

00



10

Special Laminated Surface - Wood Effect



B01



X41



61M



V32



WGB



WG9

Special Laminated Surface - Fenix - [www.fenixforinteriors.com](http://www.fenixforinteriors.com)

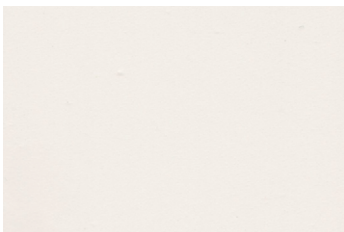

0029

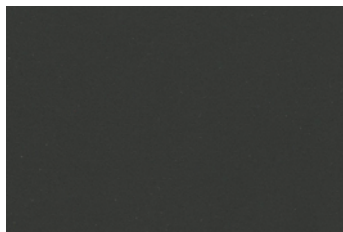

720

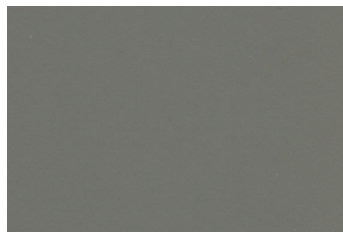

718



2630



2629



2628

# COLOURS AND COVERINGS

## COLORI E RIVESTIMENTI

### Marble Surface



MBC - BIANCO CARRARA



MNM - NERO MARQUINA



MVG - VERDE GUATEMALA



MED - EMPERADOR DARK

### Porcelain Surface



PCO - CALACATTA ORO

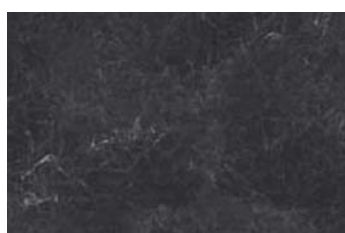

PNG - NERO GRECO

## K King Fabric / Tessuto King



6001

6091

6034

6052

7019

7022

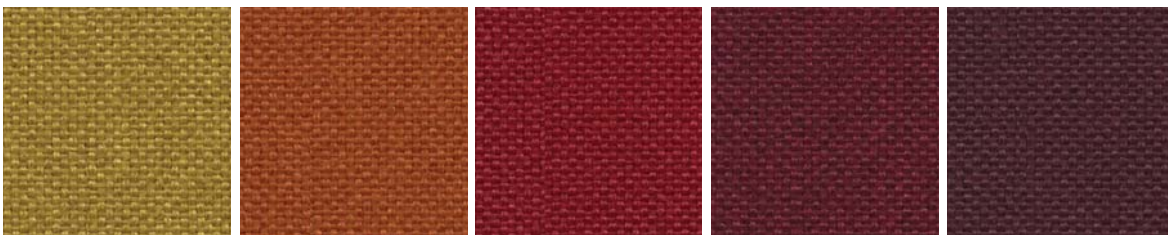

3030

3082

4021

4032

5001

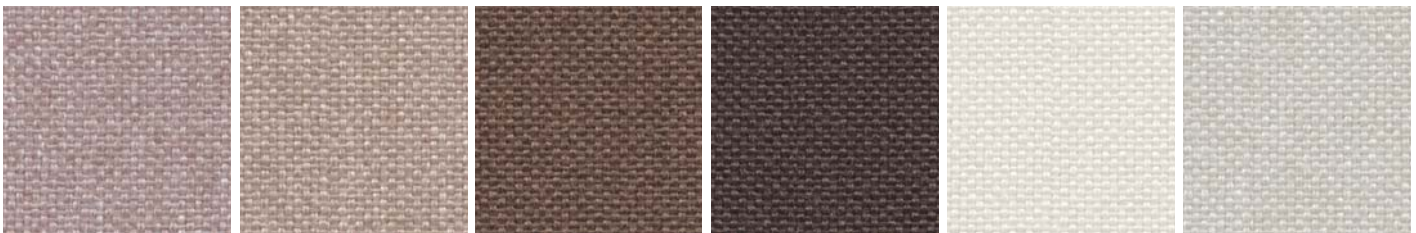

1033

1008

2003

2007

1012

1025

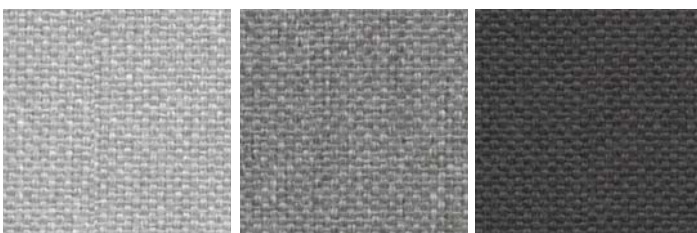

8032

8006

8011

- Composition: 100% POLYESTER - TREVIRA CS
- Abrasion: UNI EN ISO 12947-2 80.000 Cycle Martindale  $\pm 10\%$
- Light Resistance-Xenotest: UNI EN ISO 105-B02 / 6 (tol from 5 to 8)
- Fire proof: UNI 9174 - 8456 Class C1, UNI 9175 Class 1, DIN 4102 Class B1, NF 92501-7 Class M1, NF D 60013, 1IM (UNI 9175) Class AM18, EN 1021-1 & 2, BS Crib 5, BS 7176 Class Medium Hazard, EN 13773 Class 1, OENORM 3800-1 Class B1,Q1,TR1, California TB117, USA NFPA 701, USA NFPA 260, IMO A 652 (16) Part 8 Upholstery
- Maintenance: Standard 60° C cotton cycle.

Visit [www.fidivi.com](http://www.fidivi.com) for complete colours range / Visionate la completa gamma colori su [www.fidivi.com](http://www.fidivi.com)

# COLOURS AND COVERINGS

## COLORI E RIVESTIMENTI

L King L Fabric / Tessuto King L



6071

3090

4027



1010

1025

8014

8010

- Composition: 100% POLYESTER
- Abrasion: UNI EN ISO 12947/2 70.000 Cycle Martindale  $\pm 10\%$
- Light Resistance-Xenotest: UNI EN ISO 105-B02 / 6 (tol from 5 to 8)
- Fire proof: UNI 9174 - 8456 Class C1, DIN 4102 Class B1, NF P 92501-7 Class M1, IMO Res. A652 (16), NF D 60013 Class AM18, EN 1021-1 & 2, BS 5852 part II Crib 5, BS 7176 Medium Hazard, ONORM B 3825-Onorm A 3800-1 Class B1-Q1-TR1, Euroclass EN 13501-1, EN 1021-1 & 2, IIM (UNI 9175), California TB 117
- Maintenance: Use vacuum-cleaner, don't brush.

Visit [www.fidivi.com](http://www.fidivi.com) for complete colours range / Visionate la completa gamma colori su [www.fidivi.com](http://www.fidivi.com)

**DK Kvadrat Fabric (Steelcut2) / Tessuto Kvadrat (Steelcut2)**



835

760

780

950

975

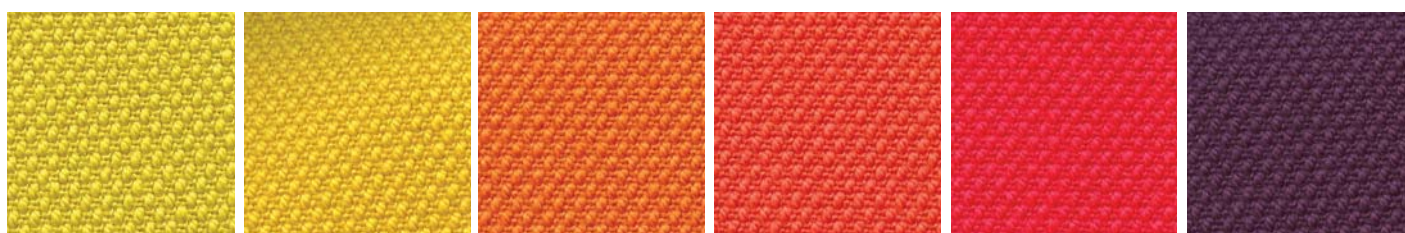

435

445

535

550

635

625



685

255

365

655

110

140

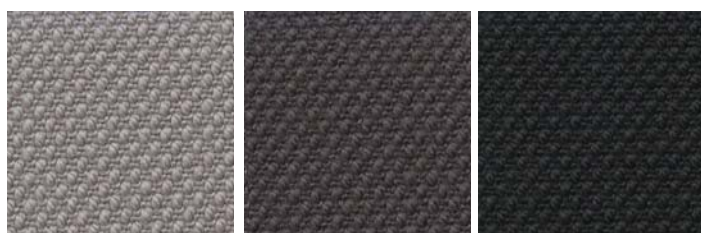

155

180

190

- Composition: 90% New wool worsted - 10% Nylon
- Abrasion: 100.000 Martindale rubs, EN ISO 12947
- Lightfastness: Note 5-7, ISO 105-B02
- AS/NZS 1530.3, BS 5852 crib 5 with treatment, BS 5852 part 1, IMO FTP Code 2010 Part 8, NF D 60 013, NFPA 260, SN 198 898 5.3 with treatment, UNI 9175 1IM, US Cal. Bull. 117-2013, EN 1021-1/2, AS/NZS 3837 class 2, ÖNORM B1/Q1, ASTM E84 Class A Unadhered, ASTM E84 Class B Adhered

Visit [www.kvadrat.dk](http://www.kvadrat.dk) for complete colours range / Visionate la completa gamma colori su [www.kvadrat.dk](http://www.kvadrat.dk)

# COLOURS AND COVERINGS

## COLORI E RIVESTIMENTI

DK Kvadrat Fabric (Remix3) / Tessuto Kvadrat (Remix3)



733

722

743

753

923

942



672

982

973

612

422

632



653

682

692

233

113

123



143

183

- Composition: 90% wool, 10% nylon
- Abrasion: Approximately 100.000 Martindale rubs, EN ISO 12947
- Lightfastness: Note 5-7, ISO 105-B02
- AS/NZS 1530.3, BS 5852 crib 5 with treatment, BS 5852 ignition source 3, BS 5852 part 1, IMO FTP Code 2010 Part 7 with treatment, IMO FTP Code 2010 Part 8, NF D 60 013, NFPA 260, SN 198 898 5.3 with treatment, UNI 9175 1IM, US Cal. Bull. 117-2013, EN 1021-1/2, AS/NZS 3837 class 2, ÖNORM B1/Q1, ASTM E84 Class A Unadhered, ASTM E84 Class A Adhered, GB 50222 B1 with treatment

Visit [www.kvadrat.dk](http://www.kvadrat.dk) for complete colours range / Visionate la completa gamma colori su [www.kvadrat.dk](http://www.kvadrat.dk)

## S Superb Trevira Fabric / Tessuto Velvet-Velluto



5130

5127

5131

5140

5134

5135

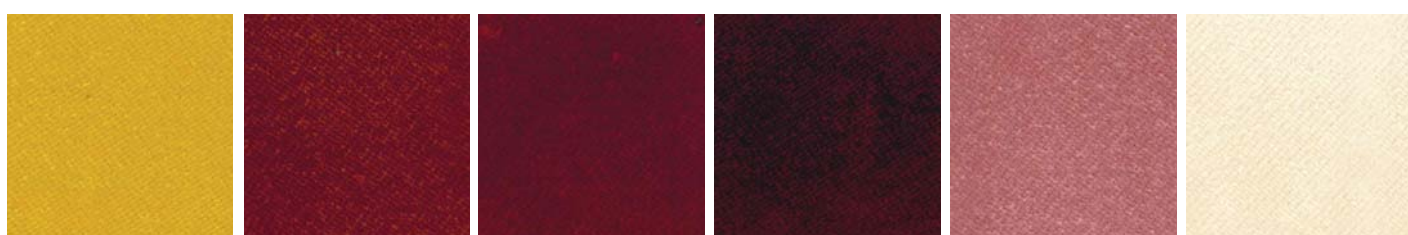

5106

5112

5118

5119

5114

5103



5144

5143

5149

5142

5145

5152

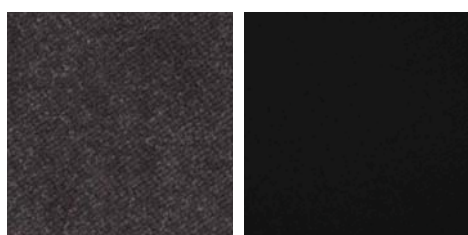

5151

5147

- Composition: 100% POLYESTER - TREVIRA CS
- Abrasion: UNI EN ISO 12947-2 100.000 Cycles
- Light Resistance-Xenotest: UNI EN ISO 105-B02  $\geq 5$  Blue Scale
- Fire proof: UNI 8456 - 9174 classe 1, UNI 9175 classe 1IM, EN 1021-1  
EN 1021-2, BS 5852 crib 5, DIN 4102 B1, NF P 92 503-507 M1, TB 117:2013  
UNI EN 13773:2004 classe 1, NFPA 701:2015
- Maintenance: Dust gently or pass the surface with a damp cloth.

Visit [www.flukso.it](http://www.flukso.it) for complete colours range / Visionate la completa gamma colori su [www.flukso.it](http://www.flukso.it)



# COLOURS AND COVERINGS

## COLORI E RIVESTIMENTI

### B Blazer Fabric / Tessuto Blazer



CUZ2Z

CUZ1E

CUZ86

CUZ47

CUZ1T

CUZ2R

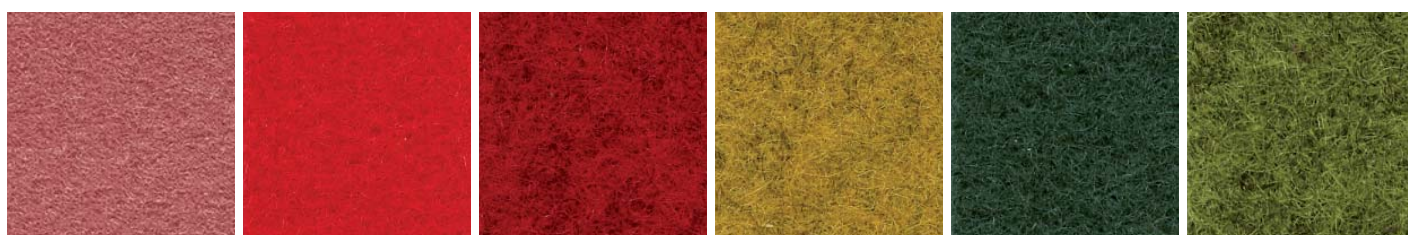

CUZ3D

CUZ18

CUZ63

CUZ82

CUZ1N

CUZ1K

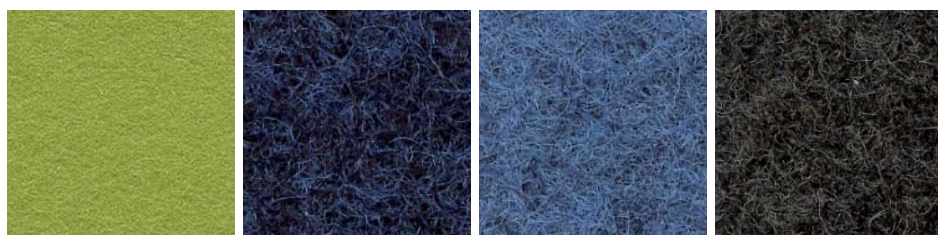

CUZ2X

CUZ62

CUZ1W

CUZ67

- Composition: 100% VIRGIN WOOL
- Abrasion: BS EN ISO 12497-2 65.000 Cycle Martindale
- Light Resistance-Xenotest: UNI EN ISO 105-B02 / 5
- Fire proof: BS EN 1021 Part 1, BS EN 1021 Part 2, BS 7176 Low Hazard, BS EN 13501-1:2007 Class D, NF D 60-013 AM18, UNI 9175:2010 Class 11M, BS476 part 7 Class 1, ONORM B 3825, IMOFTP Code (part 8)
- Maintenance: Use the vacuum-cleaner.

Visit [www.camirafabrics.com](http://www.camirafabrics.com) for complete colours range / Visionate la completa gamma colori su [www.camirafabrics.com](http://www.camirafabrics.com)

## M Miki Fabric / Tessuto Miki

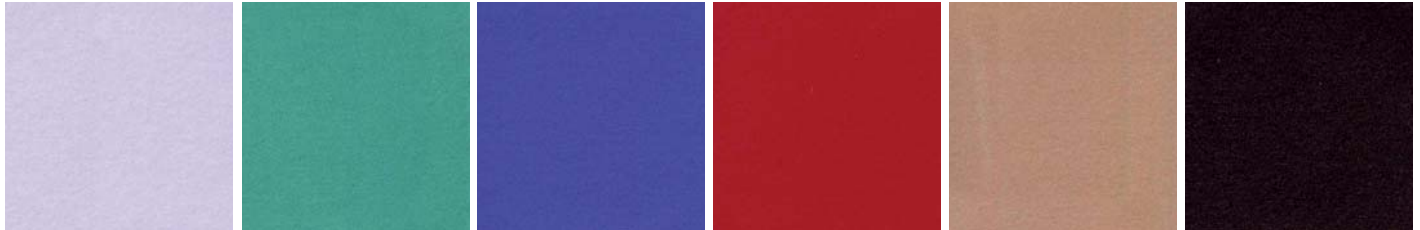

6445

6490

6713

6432

6334

NERO

- Composition: Composizione 100% PL 65/75 g/m<sup>2</sup> – Composition 100% PL 65/75 g/m<sup>2</sup>
- Light Resistance-Xenotest: UNI EN ISO 105-B02 / 01
- Maintenance: Dust with a soft and dry cloth.

# COLOURS AND COVERINGS

## COLORI E RIVESTIMENTI

FO Fortezza 93 Fabric / Tessuto Fortezza 93

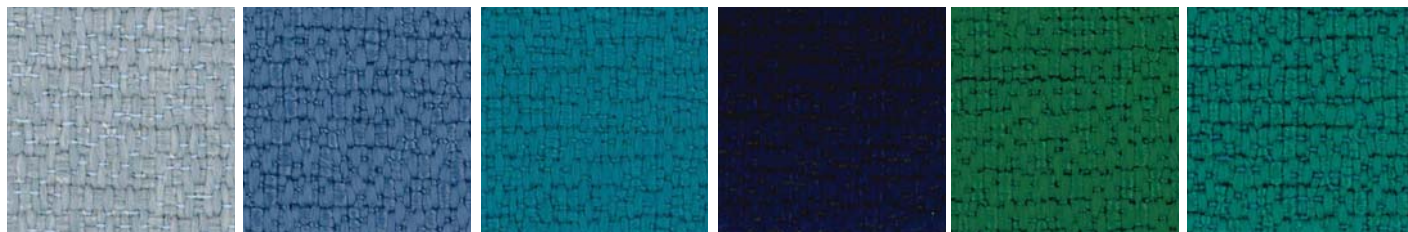

30-1

67-1

44-1

46-1

65-1

56-1

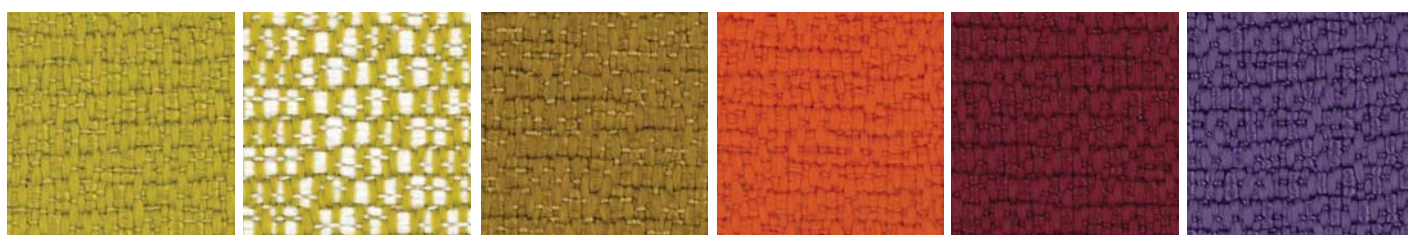

43-1

43-2

48-1

47-1

69-1

68-1

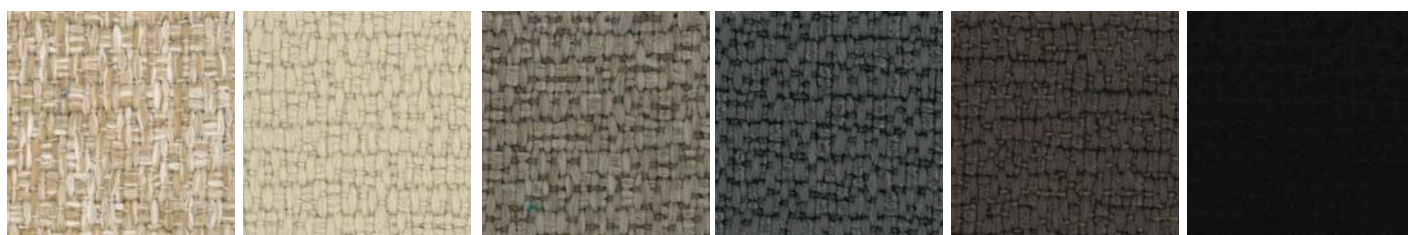

23-1

66-1

24-1

41-1

64-1

42-1

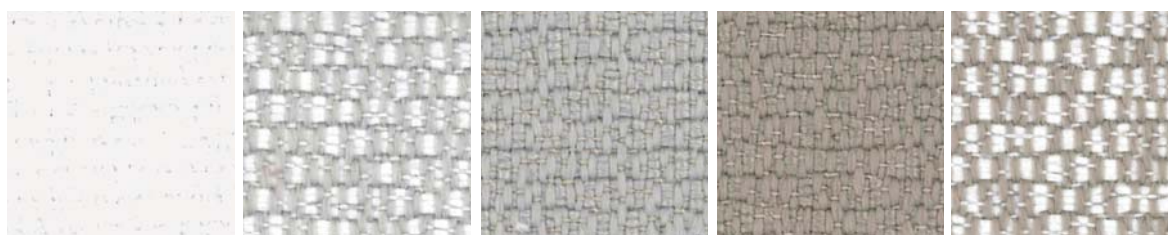

38-1

39-2

39-1

17-1

17-2

- Composition: 100% Polyolefinic
- Abrasion: UNI EN ISO 12947 35.000 rubs/cicli
- Seam slippage: BS 2543
- Pilling: UNI EN ISO 12945-2
- Colour fastness Dry Rubbing: UNI EN ISO 105-X12
- Colour fastness Wet Rubbing: UNI EN ISO 105-X12
- Light Fastness: UNI EN ISO 105-B02, UNI EN ISO 105-B04
- Colour Fastness to Sea Water: UNI EN ISO 105:E02:1996
- Colour Fastness to Chlorinated Water: UNI EN ISO 105:E03:2010
- Flammability: UNI 8456 - 9174 - CLASS 1 - ITALIAN FIRE SAFETY CLASSIFICATION - PASS, BS EN 1021.1:1994 - SOURCE 0 - CIGARETTE TEST - PASS, BS EN 1021.2:1994 - SOURCE 1 - BUTANE FLAME - PASS ON FR FOAM, T.B. 117 (2013): SECTION 1 POSITIVE, B1 ACCORDING TO DIN 4102, PART 1 (MAY 1998), NFPA 260:2013 - CLASS 1, IMO 2010 FTP CODE PART 8 - Resolution MSC 307(88) - Cigarette and Match Test, EN 13773 (2004) CLASS 1

Visit [www.primafabrics.it](http://www.primafabrics.it) for complete colours range / Visionate la completa gamma colori su [www.primafabrics.it](http://www.primafabrics.it)

## GR Progarden Fabric / Tessuto Progarden

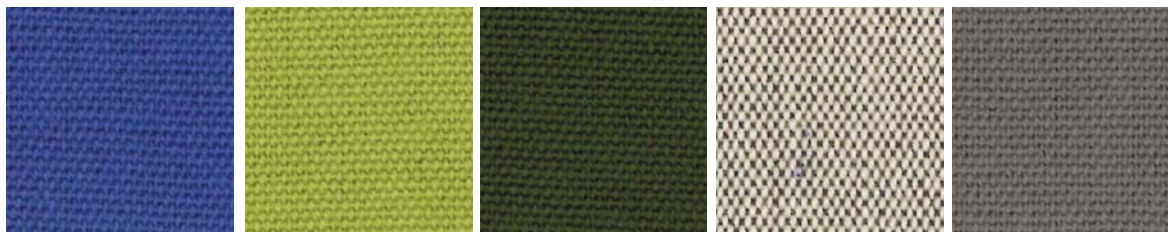

**051**  
**MEDITERRANEAN BLUE**

**026**  
**PISTACHIO**

**028**  
**OLIVE GREEN**

**012**  
**LINEN**

**683**  
**SLATE**

- Composition: 100% yarn dyed acrylic
- Martindale (ISO 12947-2): 15.000 cycles
- Dimensional change after washing at 40°C and drying (warp/weft) (ISO 5077): ± 2%/0%
- Breaking strength (warp/weft) (ISO 13934-1): 200/70 daN
- Elongation at break (warp/weft) (ISO 13934-1): 25%/25%
- Tear strength (warp/weft) (ISO 13937-1): 7/3,7 daN
- Resistance to seam (warp/weft) (ISO 13935-1): 50/50 daN

- Air permeability (ISO 9237): 65 l/m<sup>2</sup>/s
- Finishing: Water repellent Teflon/Scotchgard treatment, dirt repellent and anti-mould treatment
- Spray Test (ISO 4920): 4 out of 5
- UV Colour fastness (ISO 105 B02): 5/8 out of 8
- Colour fastness to weather (ISO 105 B04): 5/8 out of 8
- Colour fastness after washing at 40°C (ISO 105 C06): 5 out of 5

Visit [www.giovanardi.com](http://www.giovanardi.com) for complete colours range / Visionate la completa gamma colori su [www.giovanardi.com](http://www.giovanardi.com)

## SX Silvertex Fabric / Tessuto Silvertex



**3066**  
**BALTIC**

**5020**  
**BASIL**

**1014**  
**UMBER**

**0002**  
**SANDSTONE**

**4004**  
**ICE**

**4003**  
**GRAPHITE**

- Composition: 100% Vinyl / Polyester Backing
- Abrasion: >300.000 cycles Martindale (EN ISO 12947:1999 Part 2)
- UV Resistance: ISO 105 B04 ≥ 4/5 (Grey Scale), ISO 105 B02 ≥ 7/8 (Blue Wool Scale)
- Flame Retardancy: EU: EN 1021 Part 1 & 2

DE: DIN 4102 B2 ECE Regulation No.118:03 (R118.02 Annexes 6, 7 & 8), ES: UNE 23.727-90 1R/M.2, FR: NF P 92-503/M2, IT: UNI 9175 (1987) / UNI 9175/FA1 (1994)  
Classe 1.1M (UNO I EMME), AT: ÖNORM B 3825, Gruppe 1 - Schwerbrennbares Verhalten, AT: ÖNORM A 3800 Teil 1, Qualmbildungsklasse Q1 - schwachqualmend, IMO FTP 2010  
Code MSC.307 (88) Part 8 3.1 & 3.2, (MED) Marine Equipment Directive (in its current valid version), EN 71-2:2006+A1:2007 - Safety of Toys - Parte 2: Flammability, US: CAL TB 117-2013, Section E, FMVSS 302, FAR 25/853

Visit [www.spradling.eu](http://www.spradling.eu) for complete colours range / Visionate la completa gamma colori su [www.spradling.eu](http://www.spradling.eu)

# COLOURS AND COVERINGS

## COLORI E RIVESTIMENTI

### R Mesh Fabric / Tessuto Rete

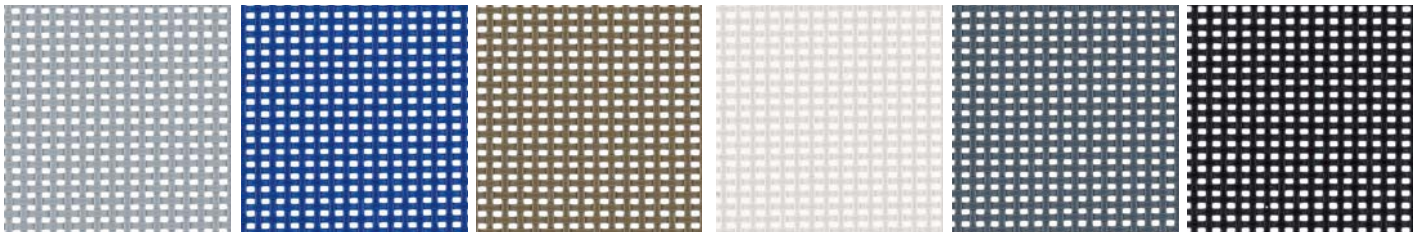

R08

R10

R09

R01

R03

R02

- Composition: Polyvinyl 70% - Polyester 30%
- Warp Tensile Strength: 310Kg/5cm
- Weft Tensile Strength: 270Kg/5cm
- Fire retardant on request

Visit [www.plastitex.com](http://www.plastitex.com) for complete colours range / Visionate la completa gamma colori su [www.plastitex.com](http://www.plastitex.com)

### MG Maglia Vinyl Fabric / Tessuto Maglia Vinile

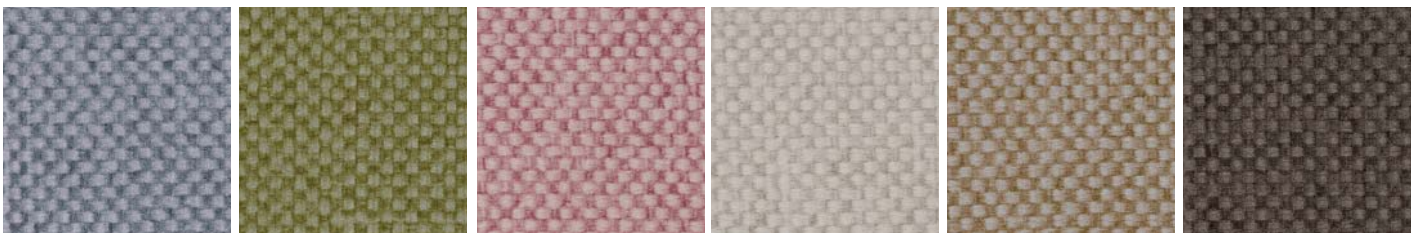

0003

0406

4203

5001

6025

4537

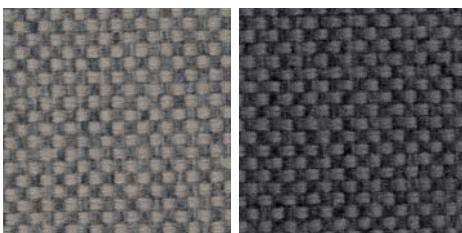

1702

6016

- Composition: Vynil 100%
- Abrasion: >100.000 cycles Martindale (EN ISO 12947:1999 Part 2)
- Fire Proof: EN 1021 Part 1 & 2, UNE 23.727-90 1R/M.2, NF P 92-503/M2, DIN 4102 B2, UNI 9175 (1987) / UNI 9175/FA1 (1994) Classe 1.1M (UNO I EMME), ÖNORM B 3825, Gruppe 1 - Schwerbrennbares Verhalten, ÖNORM A 3800 Teil 1, Qualmbildungsklasse Q1 - schwachqualmend, IMO FTP 2010 Code MSC.307 (88) Part 8 3.1 & 3.2, FMVSS 302, US: FAR 25/853, (MED) Marine Equipment Directive (in its current valid version), ECE R118.02 (replaces Directive 95/28/CE) Annexes 6, 7 & 8, EN 71-2:2006+A1:2007 - Safety of Toys - Parte 2: Flammability, CAL TB 117-2013, Section E
- Light Resistance: UV-Resistance XENOTEST DIN 54004/ NTC 1479

Visit [www.spradling.eu](http://www.spradling.eu) for complete colours range / Visionate la completa gamma colori su [www.spradling.eu](http://www.spradling.eu)

## E Simil leather Aurea / Ecopelle Aurea



23

7

14

15

16

8



9

10

17

19

21

11



2

3

5

6



1

22

28

26

- Composition: 72% PVC - 3% PU - 25% COTTON
- Abrasion: EN ISO 5470-2 100.000 Cycle Martindale
- Light Resistance-Xenotest: UNI EN ISO 105-B02 / 6
- Fire proof: UNI 9175 classe 1IM, EN 1021-1, EN 1021-2, BS 5852-1 cigarette test, BS 5852-1 match test  
BS 5852 crib 5, TB 117:2013, IMO res. A.652(16)
- Maintenance: Dust gently or pass the surface with a damp cloth.

Visit [www.flukso.it](http://www.flukso.it) for complete colours range / Visionate la completa gamma colori su [www.flukso.it](http://www.flukso.it)

# COLOURS AND COVERINGS

## COLORI E RIVESTIMENTI

### C Leather / Cuoio

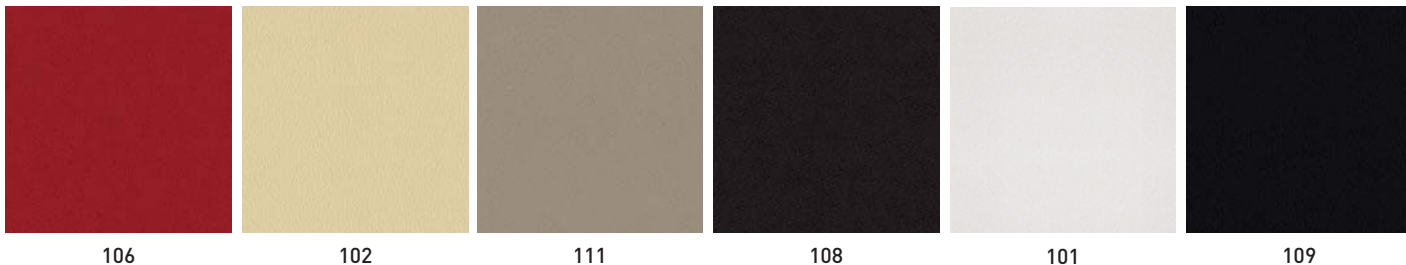

106

102

111

108

101

109

- Composition: 100% Grain Leather, Italian tannery
- Light Resistance: IUF/101
- Fire proof: CAL TB 117-00, Section E -part 1; BS 5852/90 section 4 (CRIB 5); UNI 91/75 Classe 2IM
- Maintenance: Dust gently or pass the surface with a damp cloth.

### P Leather / Pelle



106P

102P

111P

110P

108P

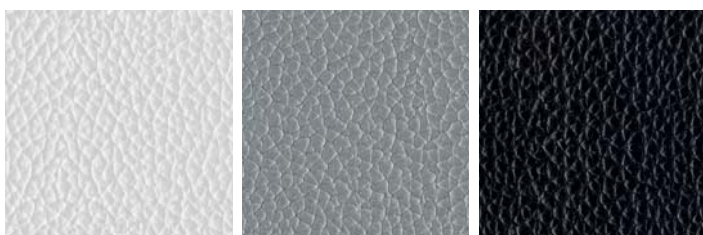

101P

112P

109P

- Composition: 100% Top Grain Leather, Italian tannery
- Light Resistance-Xenotest: UNI EN ISO 105-B02 / 6
- Fire proof: BS EN 1021 Part 1, BS 1021 Part 2, BS 5852 Part 2 (with special fire-retardant padding)
- Maintenance: Dust with a soft and dry cloth.









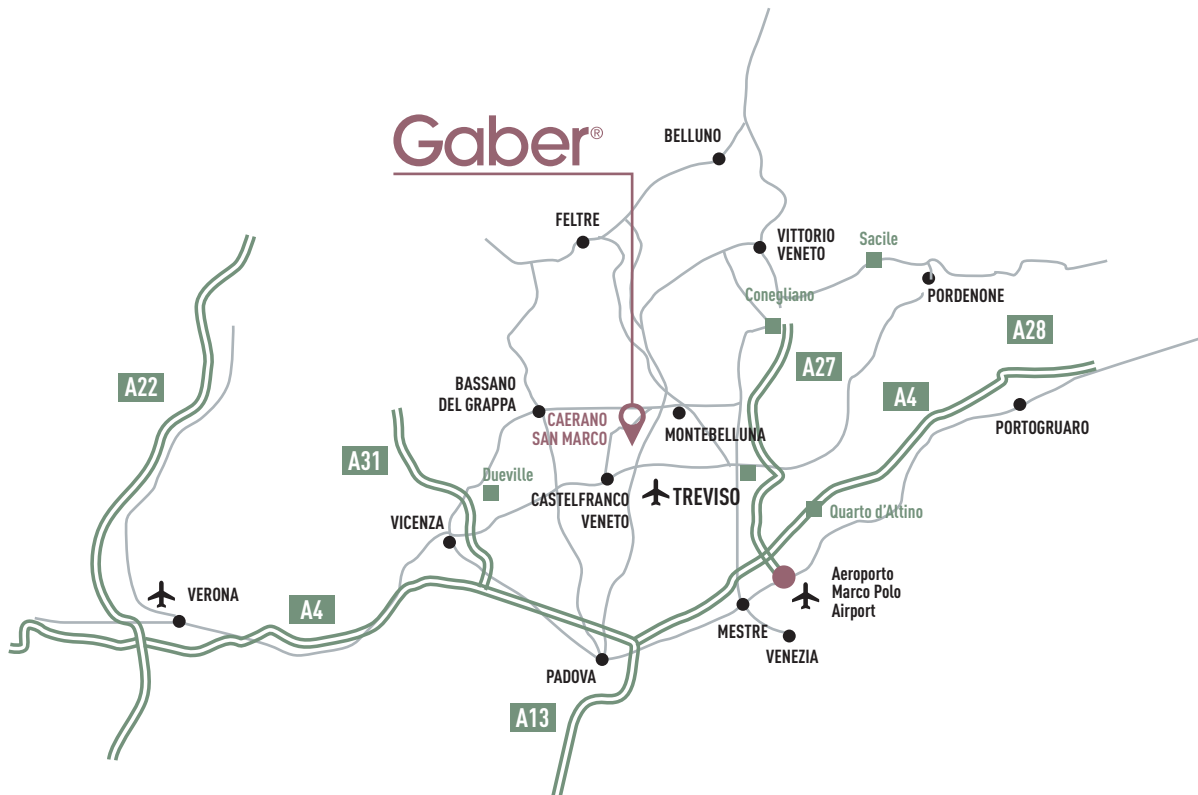

**Gaber**<sup>®</sup>  
gaber.it